

Application manual

Safe Torque Off

ACTIVE Cube



BONFIGLIOLI

General Information about the Documentation

This application manual complements the operating instructions and the „Quick Start Guide“ of the ACU frequency inverters (ACTIVE Cube series). It contains all relevant information required for using the safety-oriented function „Safe Torque Off“ (STO).

For better clarity, the documentation is structured according to the customer-specific requirements made on the frequency inverter.

Quick Start Guide

The Quick Start Guide describes the basic steps required for mechanical and electrical installation of the frequency inverter. The guided commissioning supports you in the selection of necessary parameters and the software configuration of the frequency inverter.

Operating Instructions

The Operating Instructions describe and document all functions of the frequency inverter. The parameters required for adapting the frequency inverter to specific applications as well as the wide range of additional functions are described in detail.

Application Manual

The application manual supplements the documentation for purposeful installation and commissioning of the frequency inverter. Information on various subjects connected with the use of the frequency inverter is described specific to the application.

Installation Instructions

Complementing the Brief Instructions and the Operating Instructions, the Installation Instructions provide information on how to install and use the additional/optional components.

If you need a copy of the documentation or additional information, contact your local representative of BONFIGLIOLI.

The following pictograms and signal words are used in the documentation:



Danger!

Danger refers to an immediate threat. Non-compliance with the precaution described may result in death, serious injury or material damage.



Warning!

Warning refers to a possible threat. Non-compliance with the warning may result in death, serious injury or material damage.



Caution!

Caution refers to an immediate hazard. Non-compliance may result in personal or material damage.

Attention!

Attention and the related text refer to a possible behavior or an undesired condition which can occur during operation.

Note

marks information which facilitates handling for you and supplements the corresponding part of the documentation.

TABLE OF CONTENTS

1	General Safety Instructions and Information on Use	3
1.1	Safety Instructions on Function „Safe Torque Off“ (STO)	3
2	Information of Risk Analysis and Risk Assessment	5
3	General Description of Safety Function	6
3.1	Integrated Safety Function.....	6
3.2	Functional Safety	6
3.3	Classification the safety requirement.....	6
4	Description of ACTIVE Cube Safety Function	7
4.1	Two-Channel Monitoring	8
4.2	Diagnosis function and enforced dynamizing.....	10
4.3	Diagnosis indicators.....	11
5	Requirements to be met by installation	12
5.1	Instructions on installation of safety equipment	12
5.2	External Safety Control Equipment	13
5.3	External DC 24 V power supply	13
5.4	DC 24 V Power supply by ACU	14
6	Requirements to be met in operation	14
7	Requirements to be met by acceptance inspection	14
8	Application Examples	15
8.1	Direct Stop, Stop Category 0	16
8.2	Direct Stop with Feedback to PLC, Stop Category 0.....	17
8.3	Direct Stop, Stop Category 1	18
8.4	Direct Stop with Feedback to PLC, Stop Category 1.....	19
8.5	Internal DC 24 V Supply, Stop Category 1.....	20
8.6	Group Stop, Stop Category 1	21
8.7	Error exclusion “short circuit” in the cabinet	22
9	Checklist	23
10	Safety Function Test Report	24
11	STO status (diagnosis)	24
12	Index of Change	25

1 General Safety Instructions and Information on Use

The present documentation was prepared with great care and it was subjected to extensive and repeated reviews. For reasons of clarity, it was not possible to include all details of all types of the product in the documentation. Neither was it possible to consider all conceivable installation, operation or maintenance situations. If you require further information or if you meet with specific problems which are not dealt with in sufficient detail in the documentation, contact your local BONFIGLIOLI agent.

We would also like to point out that the contents of this documentation do not form part of any previous or existing agreement, assurance or legal relationship. Neither are they intended to supplement or replace such agreements, assurances or legal relationships. The manufacturer's obligations are exclusively specified in the relevant purchase contract. This contract also contains all and any warranty regulations which may apply to the relevant scope of supply. These contractual warranty provisions are neither extended nor limited by the specifications contained in this documentation.

The manufacturer reserves the right to correct or amend the specifications, product information and omissions in these operating instructions without notice. The manufacturer shall not be liable for any damage, injuries or costs which may be caused by the aforementioned reasons.



Warning! The specifications and instructions contained in the documentation must be complied with strictly during installation and commissioning. Only qualified staff who has read and understood the documentation is allowed to carry out installation or commissioning work or to operate the devices. The safety instructions must be complied with strictly. The term „Qualified Staff“ refers to anybody who is familiar with the installation, assembly, commissioning and operation of the frequency inverter and has the proper qualification for the job.

The present documentation complements the operating instructions ACTIVE Cube (ACU). It contains additional safety information and requirements for the operation or ACTIVE Cube (ACU) in safety-oriented applications. Use in safety-oriented machines shall be permissible only after this documentation has been read carefully and understood. The applicable basic standards as well as application-specific and specific national standards shall also be complied with – the standards referred to in this manual shall also be complied with.

1.1 Safety Instructions on Function „Safe Torque Off“ (STO)

The function „Safe Torque Off“ (STO) is a functional safety provision, i.e. it protects staff from damage, provided that projecting, installation and operation are performed properly. This function does not disconnect the machine from power supply.

The safety function „Safe torque off“ (STO) can be used to realize an „Emergency Stop“ while the power supply is still active on the frequency inverter.

According to EN 60204 a provision must be provided for disconnecting the machine from power supply for maintenance work.



Warning! Improper installation of the safety technique can cause an uncontrolled starting of the drive. This may cause death, serious injuries and significant material damage.

Safety functions may only be installed and commissioned by qualified staff.

The STO function is not suitable for emergency stop as per EN 60204. An emergency stop can be realized by installing a mains contactor.

An emergency stop according to EN 60204 must be functioning in all operation modes of the frequency inverter. Resetting of an emergency stop must not result in uncontrolled starting of the drive.

The drive is started again when the function STO is no longer triggered. In order to comply with EN 60204, it must be ensured by taking external measures that the drive does not start without prior confirmation.

Without a mechanical brake, the drive might not stop immediately but coast to a standstill. If this may result in personal or material damage, additional safety measures must be taken.

If persons may be endangered after disconnection of the motor control by STO, access to the hazard areas must be prevented until the drive has stopped.

Check the safety function at regular intervals according to the results of your risk assessment. BONFIGLIOLI VECTRON recommends that the check is performed after one year, at the latest.

The STO function is one fault fail-safe. No single fault or component failure can cause a disabled drive to produce motor shaft torque. Only in extremely unlikely combinations of component faults the motor shaft could move jerky with sudden acceleration (maximum 180° /number of pole pairs, for example jerky movement of 90° for 4-pole motor, $180^\circ/2$) and produce torque. It must be checked if this behavior can cause a dangerous machine movement.

If the STO function is used, the special safety, installation and instructions on use instructions shall be complied with.



Warning! Dangerous voltage!

After disconnection of an external DC 24 V power supply, the DC link of the frequency inverter is still connected to mains supply.

Even if the motor control is deactivated and the motor is coasting to a standstill or has already stopped, high voltages may still be present on the motor terminals.

Before working (e.g. maintenance) on live parts, the machine must always be disconnected from mains supply (main switch). This must be documented on the machine.

When the function "Safe Torque Off" is triggered, the motor is not isolated from the DC link of the frequency inverter. High voltage levels may be present at the motor.

Do not touch live terminals.

2 Information of Risk Analysis and Risk Assessment

According to the Directive on Machinery 98/37/EC, the manufacturer of a machine is obliged to carry out a risk analysis in order to identify the hazards related to the machine.

The Standard EN 14121-1 – Safety of machinery - Risk assessment – Principles – describes the information required for risk assessment.

Risk assessment is effected according to the following criteria:

- degree of injury (serious/minor)
- frequency or duration of stay (frequent/seldom)
- possibilities of avoidance (hardly possible/possible)

For defined risks the Standards EN ISO 13849-1, IEC 61508 or EN 954-1 can be used to accomplish a correct classification into Safety category, SIL (Safety Integrated Level) or PL (Performance Level). These standards contain design principles for safety-relevant parts of control systems.

In the case of the safety function "Safe Torque Off", the risk assessment must consider the fact that the motor will coast to a standstill in the case of an error. Depending on the application, a mechanical brake may be required.

Responsibility:

The **Manufacturer** shall be responsible for the safety of the machine.

- risk analysis of hazards originating from the machine
- measures for reduction and elimination of the risks
- documentation of residual risk from the point of view of the manufacturer
- selection of suitable controller, installation of protective equipment, ergonomics, documentation, warning of remaining risks

The **operator** of the machine is responsible for the safety of the application.

- risk analysis of hazards originating from the use of the machine
- documentation of residual risk from the point of view of the operator
- safe operation and protection of operating staff (barriers, instruction of operating staff, etc.)

Selection of safety function:

- Risk analysis and risk assessment for machine (standards EN 12100-1, EN 12100-2 and EN 14121-1)
- Risk reduction by machine design
- If not possible by design: risk reduction by protective equipment
- Identification of safety requirements
- Selection of category of safety function
 - PL d according to EN ISO 13849-1
 - SIL 2 according to IEC 61508
 - Category 3 according to EN 954-1

Note: The Standard EN954-1 is replaced by the standard EN ISO 13849-1. The legislator has scheduled a transition period until 11-30-2009.

3 General Description of Safety Function

3.1 Integrated Safety Function

Electronic protection systems are integrated in the drive control system and perform safety functions in order to minimize or eliminate hazards caused by functional errors of machines.

The integrated safety functions replace time-consuming and expensive installation of external safety components.

The safety function can be requested or triggered by an error.

In hazard areas, setup work or work for elimination or errors may be required where the safety function is not to be activated by isolating protection devices such as mains contactors or motor contactors. Here, the additional safety function may be used. STO can be used as an alternative to mains or motor contactors, which can be omitted dependent on the application.

The integrated safety functions reduce the risk of personal damage in hazard areas and reduce installation requirements.

3.2 Functional Safety

The safety function of the control system must be ensured for normal, trouble-free operating states as well as in the case of an error. As a result of this requirement:

- The safety function must be checked in case errors are present. Possible methods include: error tree analysis, FMEA, etc.).

3.3 Classification the safety requirement

The integrated safety function “Safe Torque Off” of the ACU frequency inverter meets the following requirements:

- up to safety integrity level SIL 2 according to DIN EN 61508 for STO (STO, Safe Torque Off according to EN 61800-5-2)
- of category 3 according to DIN EN 954-1 (safe stop)
- up to performance level d according to EN 13849-1

In the case of an error, thanks to the safety function STO, the frequency inverter does not supply energy to the motor which would cause a revolution or torque (or a movement or force in the case of a linear motor).

Characteristic for the classification mentioned above:

- If an error occurs, the safety function is maintained.

By using appropriate safety control devices, stop category 0 and stop category 1 according to EN 60204 can be achieved in the machine. For safety control devices, please refer to chapter 8.

Stop category 0: Stop by immediate disconnection of energy supply to the machine drive elements, i.e. uncontrolled stop.

Stop category 1: Controlled stop, where energy is still being supplied to the drive elements of the machine to perform the stopping operation. Energy supply is stopped only after the drive has come to a standstill.

Note that the drive may not stop immediately but coast to a standstill. If no mechanical brake is installed, or a defective brake may involve a risk, further protective measures (in example tumbler) are to be taken.

4 Description of ACTIVE Cube Safety Function

The frequency inverters of the ACU series of devices feature the integrated safety function „Safe torque off, STO“.

In the case of an error or if requested, the power semiconductors of the frequency inverter will be switched off. After this, the frequency inverter does not supply energy to the drive which would cause a revolution or a torque (or a movement or force in the case of a linear drive). Mains voltage is still present. The function STO can be used, for example, for safe stopping in the case of a dangerous situation or for maintenance work on the machine. If an error occurs, the machine can still be (or remain) switched off safely.

Unlike shut-down via mains contactors or motor contactors, the integrated safety function enables easy combination of drives in a machine to form functional groups. The Safe Torque Off can be limited to certain plant areas in this way. Another advantage is the fact that it is not necessary to wait until the frequency inverter has been charged and discharged. Thus, readiness of the machine for operation can be restored more quickly. Regular electro mechanic equipment are wearing out – through the usage of the STO functionality, this kind of equipment is no longer necessary and maintenance costs can be reduced.

Safe Torque Off:

- Energy supply for the rotary field of the motor is interrupted; the motor coasts to a standstill
- Used if monitoring for standstill is not required
- Accidental start of the motor is prevented
- No galvanic isolation of motor from frequency inverter DC link

Traditional System

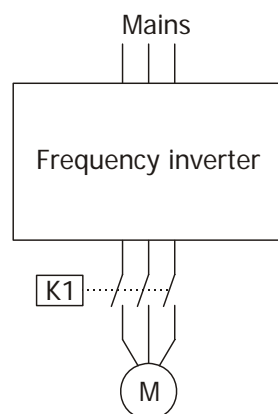

Integrated System with ACU and usage of STO

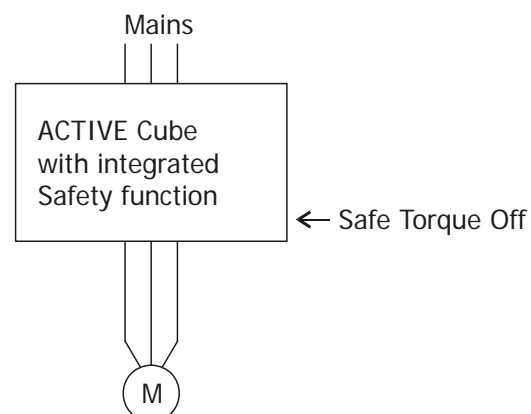

Further advantages:

- Contactors on motor side not required, reduced installation requirements, less components, more space in electrical cabinet
- Simple realization with external safety control device
- The drive can be connected to power supply continuously; communication and parameter configuration of the frequency inverter are maintained while the torque is disabled.
- Easier machine approval, because the safety function is certified via a type examination check.



Triggering of function "Safe Torque Off"

Safe Torque Off can be achieved by:

- Intentional triggering during operation in order to stop a drive and safely prevent restarting, e.g. for maintenance work on a machine.
- Triggering by actuation of an emergency stop switch or monitoring of protective systems, e.g. safety door.
- Detection of an error. The drive may only start again after the error has been acknowledged and eliminated.

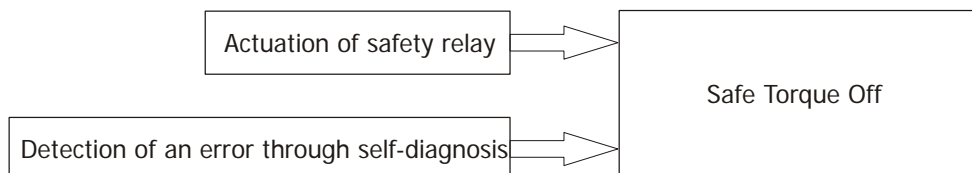

Application example:

The danger zone near a transport conveyor is monitored by a light grid. If anybody enters the danger zone, the light grid is interrupted. The DC 24 V supply for the digital inputs STO of the function „Safe Torque Off“ is switched off and the frequency inverter output stage is disabled. The drive coasts to a standstill. Disconnection from mains supply is not necessary. Communication via field bus or addressing via the terminals is still possible. An external brake which stops the motor can be addressed.

4.1 Two-Channel Monitoring

The STO function (Safe torque off) is realized via two channels in the frequency inverter (redundant design). Via two redundant monitored stop paths with no-voltage release (STOA and STOB), the frequency inverter is switched off safely even if an error occurs and the control voltage fails at the same time. Thus, the drive is stopped safely if an error occurs. An error is identified and can then be repaired (e.g. by replacing of a unit). Triggering can be effected, for example, via a two-channel contactor control with two release circuits and redundant disconnection of the main current or via a sensor or emergency stop switch with two contacts and separate cable routing to the evaluation unit.

The stop paths are monitored cyclically every 32 ms. Both stop paths are designed identically.

Via the digital inputs S1IND (STOA) and S7IND (STOB), two DC 24 V control voltages of a protection device are applied. If the protection device is actuated, the control voltages are interrupted and the pulse block is activated; energy supply to the motor is switched off. Disconnection is effected at a delay of less than 10 ms.

If the function STO is triggered, the overriding controller has no more influence on the pulse block¹ in the frequency inverter. To restart, the pulse block has to be reset and a release commanded by the operator or the superior PLC.

One single error will not result in a failure of the safety function.

¹ If the pulse block is set, the controller release is reset. If the pulse block is set, no motor revolving field is generated.

Stop paths

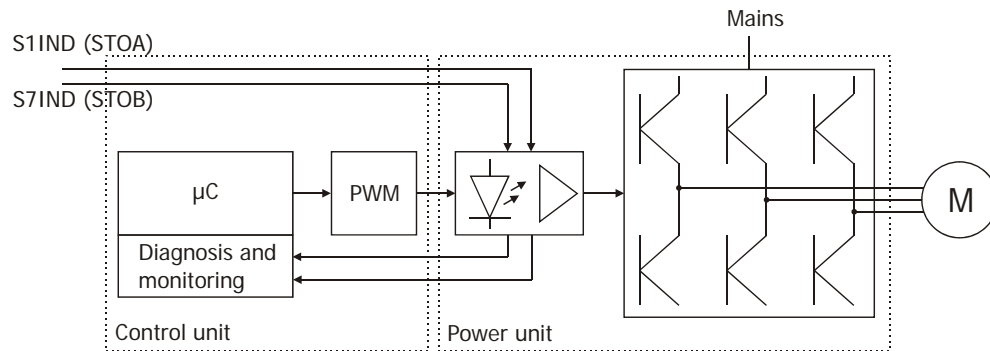

The test required for monitoring is performed by the frequency inverter automatically. If the test results negative, the frequency inverter cannot be switched on anymore. Starting is possible again only after the error has been repaired and the next test has been completed successfully.

Truth table

In the truth table, the states of the safety-relevant inputs STOA and STOB for activation and deactivation of the safety function STO are listed.

Truth table		
STOA	STOB	Description of state
0	0	Safety function "Safe Torque Off" (STO) has been triggered. The frequency inverter signals no error in STO function.
0	1	STO is triggered. Monitoring for error in frequency inverter or external circuitry (5-second monitoring). After 5 seconds, an error is signaled.
1	0	
1	1	STO is not triggered. Release for operation.

5-second monitoring

It will be checked if the two inputs STOA or STOB are switched on within an interval of less than 5 sec for requesting the release of the frequency inverter output stages. If function STO is triggered by removing one of the signals from inputs STOA or STOB, the status changes to "STO triggered". Now, the unit waits that both inputs are switched off. If this has not been done within 5 s after occurrence of this state, an error is triggered (5-second monitoring).

If, during operation, an error is detected, the output stage is switched off, the release is reset ("0") and the frequency inverter signals an error. This status can only be left by switching off ("0") the two release inputs STOA and STOB.

- Different signal states on inputs STOA or STOB start the 5-second monitoring
- Within 5 seconds, the same signal must be present of both inputs, otherwise an error will be signaled (F1205)

The function of external installation can be checked via the "5-second monitoring" by actuating the protection device.

Behavior of frequency inverter after start

- Initialization
- Monitoring for release request (5-second monitoring)
- Preparation of release (check of stop paths)
- Release of frequency inverter

Behavior of frequency inverter in the case of an error

- Switch off of IGBT in power output stage by disconnection of optocoupler supply voltage
- Suppression of control pulses of IGBT
- Setting of error bit with possibility of transfer to overriding controller
- Setting of digital output for error message
- Release of digital input for error acknowledgement.

4.2 Diagnosis function and enforced dynamizing

The two stop paths are monitored by the frequency inverter every 32 ms. If at least one of the two inputs S1IND (STOA) or S7IND (STOB) is switched off, the pulse block is activated. Additionally, a 5-second monitoring cycle begins for the other stop path. If this path is not stop within 5 s, error F1205 is output.

The test required for monitoring the stop paths is performed by the frequency inverter automatically. Via automated enforced dynamizing, the stop paths are checked for errors. If the test result is negative, the frequency inverter cannot be switched on anymore, and error F1201 is signaled. Starting is possible again only after the error has been repaired and the next diagnosis cycle has been completed successfully.

Sequence of release and monitoring states depending on signals on control inputs STOA and STOB:

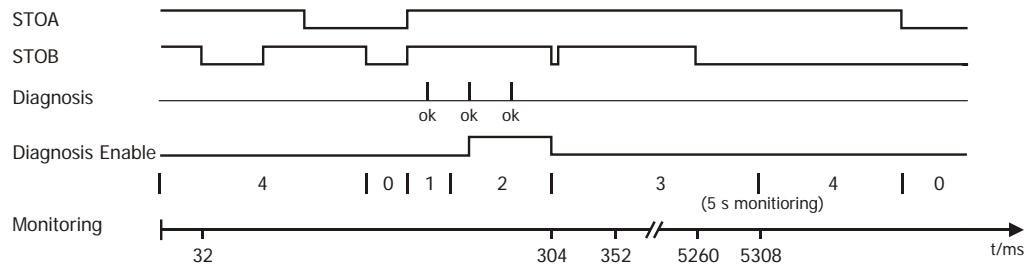
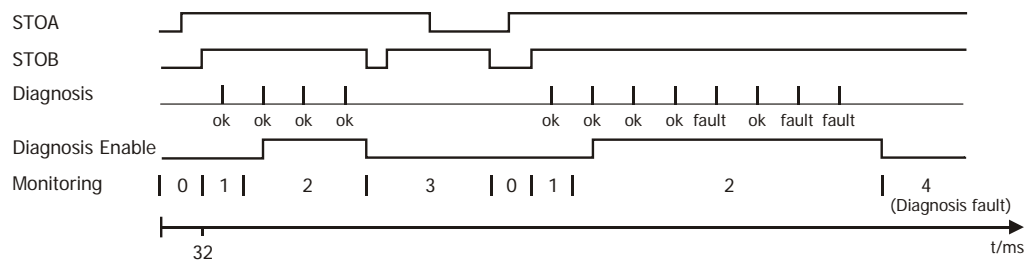

Monitoring states

- 0: Monitoring of Enable Actuation
- 1: Preparation Enable
- 2: Enable
- 3: Actuation of STO
- 4: Fault

Diagnosis fault: Only if 2 consecutive faults are recognized, the monitoring function reports a fault.

5 s Monitoring: Checks, if both inputs STOA and STOB are switched on within 5 s from each other.

In order to achieve robust operation and, for example, exclude electromagnetic interference in the signal assessment of the diagnosis function, the diagnosis is repeated when an error is detected. The frequency inverter is switched over only if another error is detected by the diagnosis function in operation status "STO Enable".

Before the frequency inverter output stages are released:

- Check if STOA and STOB are switched on less than 5 s after one another (5s monitoring). If this is the case, the release is prepared.
- Diagnosis for error in stop paths STOA and STOB. If no error is detected in the stop paths and release has been prepared, the output stages are enabled.

4.3 Diagnosis indicators

The LEDs of the frequency inverter indicate if the safety function is activated properly.

LED		Description	Rotary field on motor
green	red		
Off	Off	No supply voltage, unit is off	No
On	On	Initialization and self-test	No
Flashing	Off	Operation mode	No
On	Off	Operating message	Yes
On	Flashing	Warning message in operation	Yes
Flashing	Flashing	Ready for operation and warning message	No
Off	Flashing	Fault message	No
Off	On	Error message can be acknowledged	No

5 Requirements to be met by installation

5.1 Instructions on installation of safety equipment

- If work is to be carried out on live components, it must be possible to disconnect the machine from mains supply by means of a main switch.
- According to EN 61800-5-2 a fault exclusion can be considered with one of the following possibilities:
 - The conductor is installed permanently and in example protected against external damage with a cable duct or reinforcement.
 - Single multi-conductors are used.
 - The conductors are situated in an electrical cabinet.
 - The conductors are shielded independently and have grounding.If applicable, the requirements of EN 60204-1 have to be considered to install the connectors correctly.
- Protection against dirt is ensured if the ACTIVE Cube frequency inverters and safety control equipment is installed in electrical cabinets with high IP protection, e.g. IP 54.
- If external forces act on the drive axis, e.g. in the case of vertical axes (suspended loads) or round axes with asymmetrical weight distribution, mechanical brakes must be installed additionally.
- Only use voltage sources with safe disconnection (SELV/PELV) according to VDE0100. Comply with the specifications in chapter 5.3.
- The ACTIVE Cube frequency inverters must not be supplied with pulsed signals. Cross fault detection via pulsed signals cannot be used for this reason. Errors can be excluded in the case of the ACTIVE Cube units because the terminal blocks for the STO function are physically separate from one another. The signal cables between the safety control equipment and ACTIVE Cube must either be physically separate from one another or suitable, cross fault proof cables.
- Comply with applicable EMC instructions mentioned in the operating instructions.
- After installation, check the safety function and error reaction and issue an acceptance report.
- Interrupting the STO signals prevents a start of the motor. According to EN 60204-1, STO must not be released during an impending endangerment.
- Also comply with the instructions on external safety control equipment.
- During commissioning, check the safety function.

Select the dimensions of the safety application such that 14 mA input current is available for each of the inputs STOA and STOB. If more than one ACTIVE Cube frequency inverters are connected to one safety control device, the safety control device must provide sufficient power for all of them.

5.2 External Safety Control Equipment

Safety control equipment, upon request (e.g. actuation of emergency stop or access to hazard area, must trigger appropriate responses in order to protect people, the machine and the environment. They evaluate sensor signals or safely switch off dangerous states.

External safety control devices must meet the following requirements:

- External safety control equipment and safety modules for control of the digital inputs (STO) must meet one of the following classifications, to meet the classification of the ACU device:
 - PL d according to EN ISO 13849-1
 - SIL 2 according to IEC 61508
 - Category 3 according to EN 954-1
 - the whole installation meets these requirements
- The switching capacity of the safety control equipment must be designed for the maximum permissible, limited output current of the DC 24 power supply. Comply with the instructions of the manufacturer of the safety control equipment on the permissible contact load and any safeguards to be provided for the safety contacts.
- The emergency stop device must comply with Standard EN ISO 13850.
- If a safety request (e.g. emergency stop actuated or sensor signals that safety door is open) is reset (emergency stop unlocked, safety door closed) this alone shall not result in a restart of the drive. Restart may only occur after the safety control device has been reset.

External safety control devices evaluate sensors:

Examples of contact sensors:

- Emergency stop control device for stop in dangerous situations
- Position switch, e.g. for monitoring slide doors, safety grids or moving machine parts

Examples of no-contact sensors:

- Light barriers, e.g. for monitoring areas with dangerous movements
- Light curtains

5.3 External DC 24 V power supply

During projection and installation of a DC 24 V supply connected to the frequency inverter comply with the following instruction. This also includes supply of a safety control device the output of which is connected to a control input (including STOA and STOB) of the frequency inverter.

Attention! Use a suited SELV/PELV voltage supply, which rated voltage has to be DC 24 V $\pm 10\%$. The largest overvoltage must not exceed DC 32 V in the case of a fault (one fault safety). The one fault safety has to be realized with an overvoltage protection of the mains supply (overvoltage protection OVP with limiting the output voltage to a maximum of DC 32 V) or an external wiring like a Crowbar. An adequate overvoltage category of the voltage supply has to be ensured.

5.4 DC 24 V Power supply by ACU

You can use terminal X210A.1 in order to supply a safety control device. Only use the power supply for the device connected to the frequency inverter. Other safety control devices **must not** be connected. The maximum output current is 180 mA. The connected device must not have higher current requirements.

6 Requirements to be met in operation

During operation, the projected and commissioned machine components must not be changed. If the machine is modified a new acceptance inspection is required.

Check the safety function at regular intervals. The test intervals are to be determined according to the risk analysis. However, the check should be performed once every year, at the latest.

7 Requirements to be met by acceptance inspection

The acceptance inspection of the safety function is ordered by the manufacturer of the machine. The inspection (acceptance) shall be performed by a properly qualified person.

The result of the inspection is to be documented and must be signed by the inspector. Each safety function must be documented in detail in this report.

The inspections also include the machine documentation, including its safety functions. The safety functions must be checked particularly during the inspection and documented in the inspection report. Parameter settings shall be attached to the report. Further documents shall be added, as required, depending on the machine.

Depending on the result of the risk analysis, inspection reports of the regular inspections shall be issued and signed by the inspector.

8 Application Examples

The following examples illustrate how the “Safe Torque Off” function works. According to EN 60204, stop functions are divided in different categories. By suitable safety control devices, stop categories 0 and 1 can be realized in combination with the frequency inverter ACU.

Stop category 0: Stop by immediate disconnection of energy supply to the machine drive elements, i.e. uncontrolled stop.

Stop category 1: Controlled stop, where energy is still being supplied to the drive elements of the machine to perform the stopping operation. Energy supply is stopped only after the drive has come to a standstill.

Stop functions must always have priority over start functions and must work properly in any operation mode.

Resetting of the stop function must not cause any dangerous state.

The mechanical elements must be dimensioned properly for the stop category used. If, for example, a mechanical brake is applied in the case of fast-rotating machines via stop category 0, this brake must be able to stop the machine safely. Wear and tear of the mechanical elements must be considered during projection for the operating states and indicated in the maintenance instructions.

Stop category 0 always has priority over stop category 1.

8.1 Direct Stop, Stop Category 0

The application example shows the minimum circuitry for ACTIVE cube frequency inverters for realization of the safety function STO "Safe Torque Off" with an emergency stop device in a common electrical cabinet.

If the emergency stop device with two stop channels according to EN ISO 13849-1 PL d, IEC 61508 SIL 2 or EN954-1 Category 3 is actuated, both stop paths STOA and STOB of the ACTIVE Cube frequency inverter are interrupted and the integrated safety function with safe pulse block with SIL 2 according to EN-61800-5-2 is activated.

A (non-safe) feedback to a process controller can be effected, for example, via a connected field bus. If STO is requested, the overriding controller has no more influence on the pulse block in the frequency inverter.

Note: Terminal X210A.1 can be used for DC 24 V supply of the safety control unit. Please note the current capacity of the frequency inverter (and the current requirements of the safety control device).

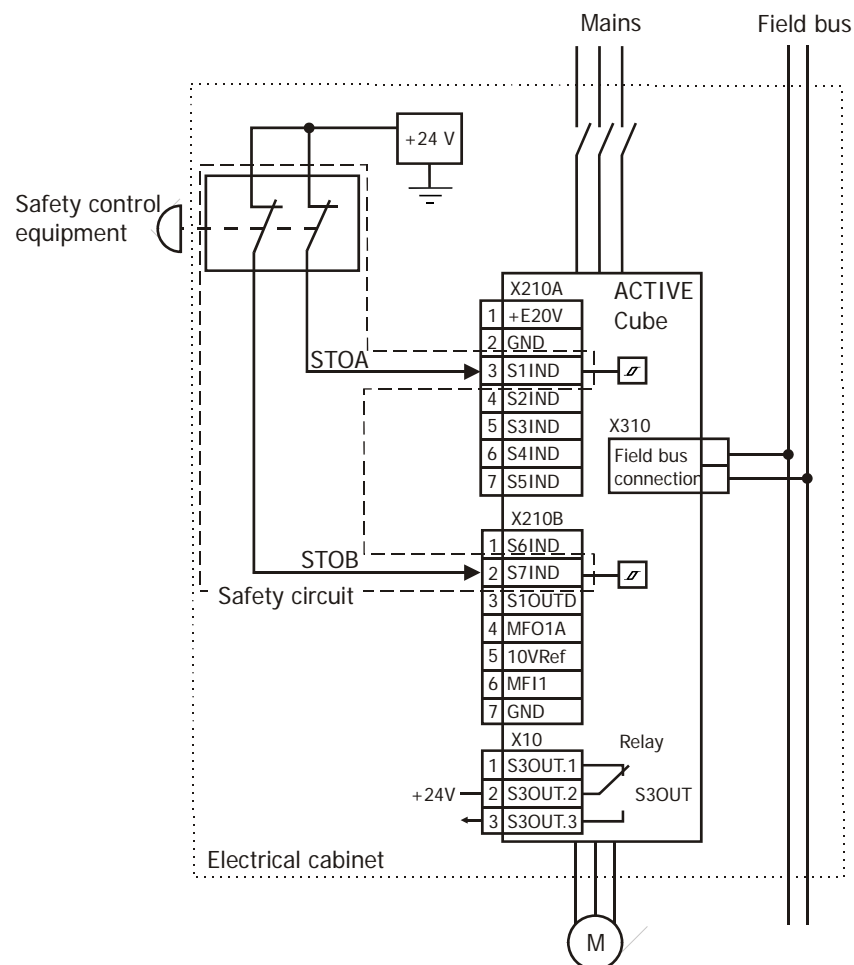

STOA: first shutdown path of the safety function STO
 STOB: second shutdown path of the safety function STO
 X210A, X210B, X10: Control terminals of the frequency inverter
 X310: Interface of communication module
 +E20V: DC 20 V voltage output or input for an external DC 24 V voltage supply
 Terminal X210A.2 : Earth 20 V/ Earth 24 V (ext.)
 S1IND ... S7IND: Digital inputs
 S1OUTD: Digital output
 MFO1A: Multi-function output (analog/digital, frequency signal)
 10VRef: Reference voltage DC 10 V
 MF11A: Multi-function input (analog/digital)
 Terminal 210B.7: Earth 10 V
 X10: Relay output

8.2 Direct Stop with Feedback to PLC, Stop Category 0

The application circuit shows a drive control system according to EN ISO 13849-1 PL d, IEC 61508 SIL 2 or EN 954-1 category 3 with PLC and safety module. A PLC performs the process control of the frequency inverter and can start the drive profiles via commands.

If the protective device is actuated, e.g. safety door open, the enable paths of the safety module are interrupted. As a result, the controller enable signal of the frequency inverter is interrupted via the disconnection of the control voltages from STOA and STOB and the integrated safe pulse block is activated.

The safety module monitors the function of the switches S1 and S2 which are located outside of the electrical cabinet.

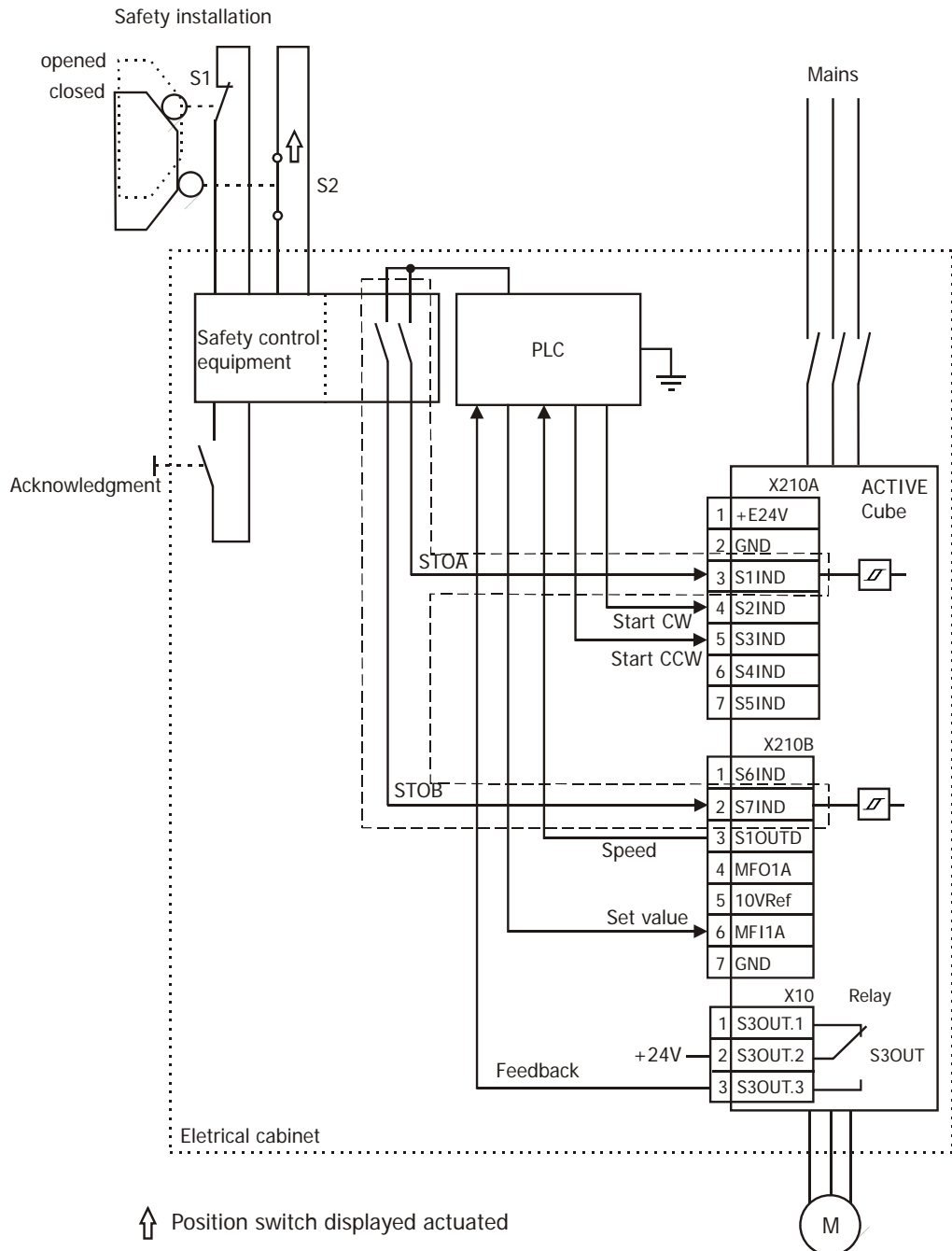

8.3 Direct Stop, Stop Category 1

The application example shows the minimum circuitry for ACTIVE cube frequency inverters for realization of the safety function STO "Safe Torque Off" with an emergency stop device in a common electrical cabinet.

When the emergency stop device is actuated, the travel command "Clockwise" is reset first. After a delay t_v , the contacts on the safety switch interrupt the two enable paths STOA and STOB of the ACTIVE Cube frequency inverter and the integrated safety function is activated. The delay time is set on the safety control device and must be selected according to the application. The set delay time has to be higher than the shut down time.

A (non-safe) feedback to a process controller can be effected, for example, via a connected field bus. If STO is requested, the overriding controller has no more influence on the pulse block in the frequency inverter.

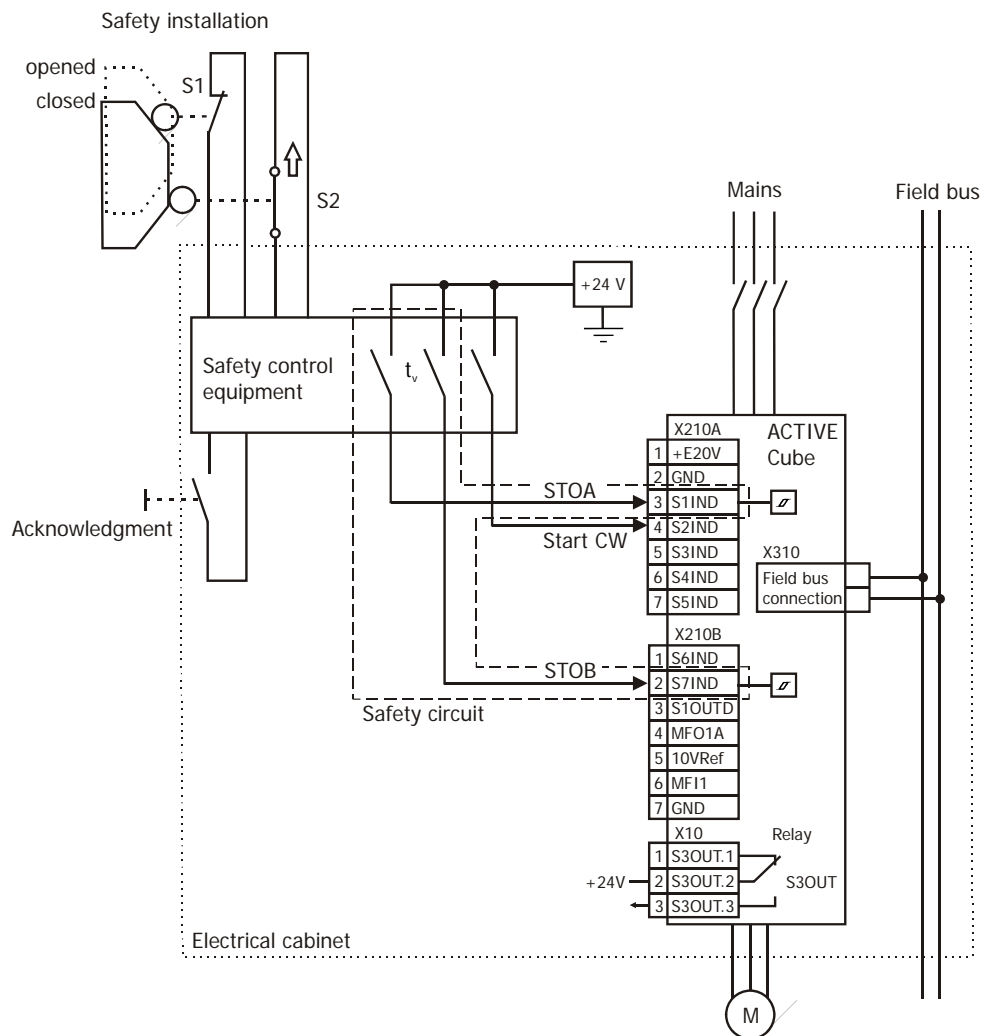

- STOA: first shutdown path of the safety function STO
- STOB: second shutdown path of the safety function STO
- X210A, X210B, X10: Control terminals of the frequency inverter
- X310: Interface of communication module
- +E20V: DC 20 V voltage output or input for an external DC 24 V voltage supply
- Terminal X210A.2 : Earth 20 V/ Earth 24 V (ext.)
- S1IND ... S7IND: Digital inputs
- S1OUTD: Digital output
- MFO1: Multi-function output (analog/digital, frequency signal)
- 10VRef: Reference voltage DC 10 V
- MF11: Multi-function input (analog/digital)
- Terminal 210B.7: Earth 10 V
- X10: Relay output
- ↑ Position switch displayed actuated
- t_v : time delay between signaling contact and shutdown contact

8.4 Direct Stop with Feedback to PLC, Stop Category 1

The application circuit shows a drive control system according to EN ISO 13849-1 PL d, IEC 61508 SIL 2 or EN 954-1 category 3 with PLC and safety module. A PLC performs the process control of the frequency inverter and can start the drive profiles via commands.

If the protective device is actuated, e.g. safety door open, the enable paths of the safety module are interrupted. At first, the PLC is informed about the fact that the safety function has been triggered. Then, the PLC decelerates the motor in a controlled way by resetting the direction of rotation (S2 or S3). After a delay t_v , the controller enable signal of the frequency inverter is interrupted via the disconnection of the control voltages from STOA and STOB and the integrated safe pulse block is activated.

The safety module monitors the function of the switches S1 and S2 which are located outside of the electrical cabinet.

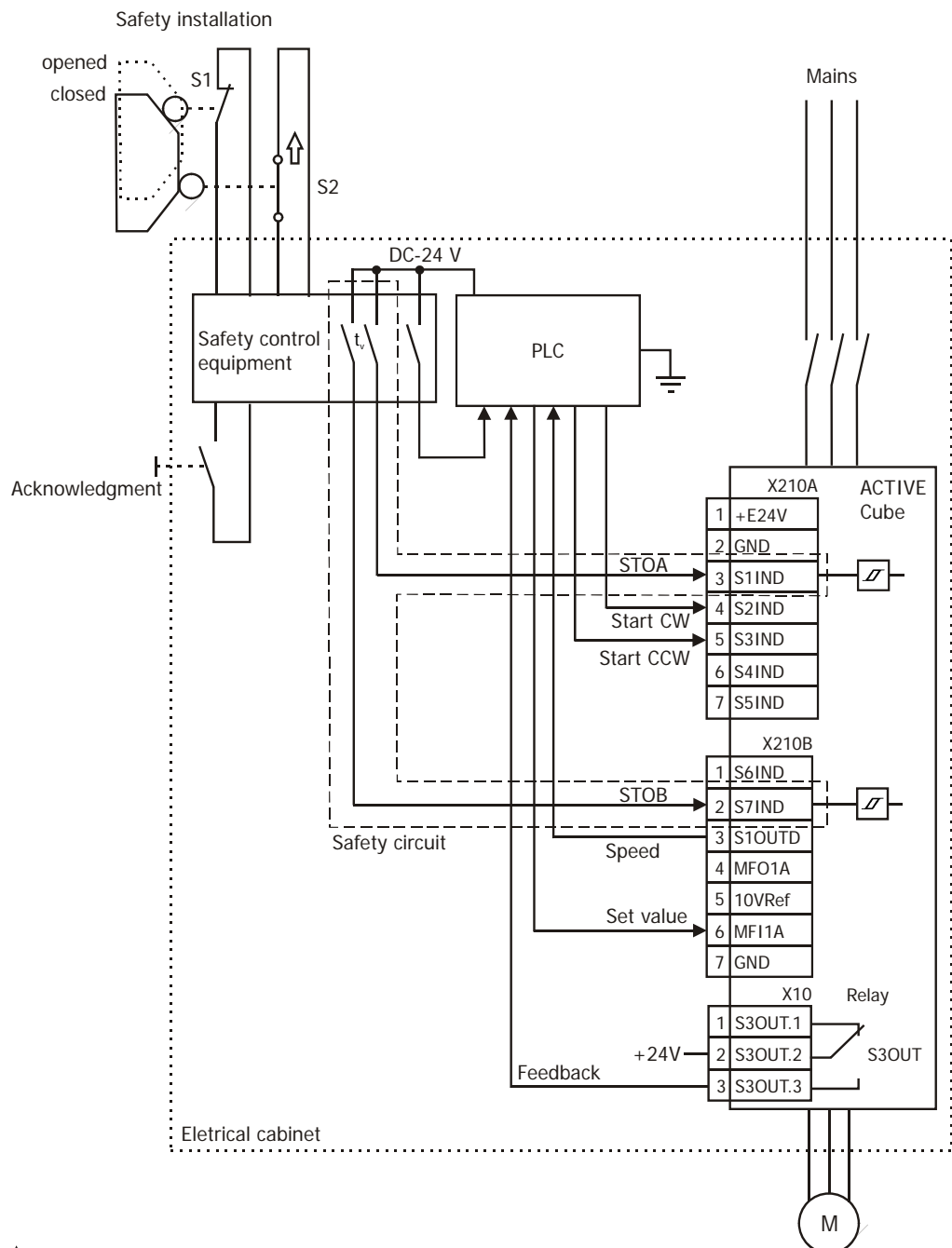

↑ Position switch displayed actuated
 t_v : time delay between signaling contact and shutdown contact

8.5 Internal DC 24 V Supply, Stop Category 1

The application example shows the minimum circuitry for ACTIVE cube frequency inverters for realization of the safety function STO "Safe Torque Off" with an emergency stop switch in a common electrical cabinet. Supply of the safety control device is effected by the internal DC 24 V supply (max. 180 mA).

When the emergency stop switch is actuated, the travel command "Clockwise" is reset first. After a delay t_v , the contacts on the safety switch interrupt the two enable paths STOA and STOB of the ACTIVE Cube frequency inverter and the integrated safety function is activated. The delay time is set on the safety control device and must be selected according to the application. The delay time is set on the safety control device and must be selected according to the application. The set delay time has to be higher than the shut down time.

A (non-safe) feedback to a process controller can be effected, for example, via a connected field bus. If STO is requested, the overriding controller has no more influence on the pulse block in the frequency inverter.

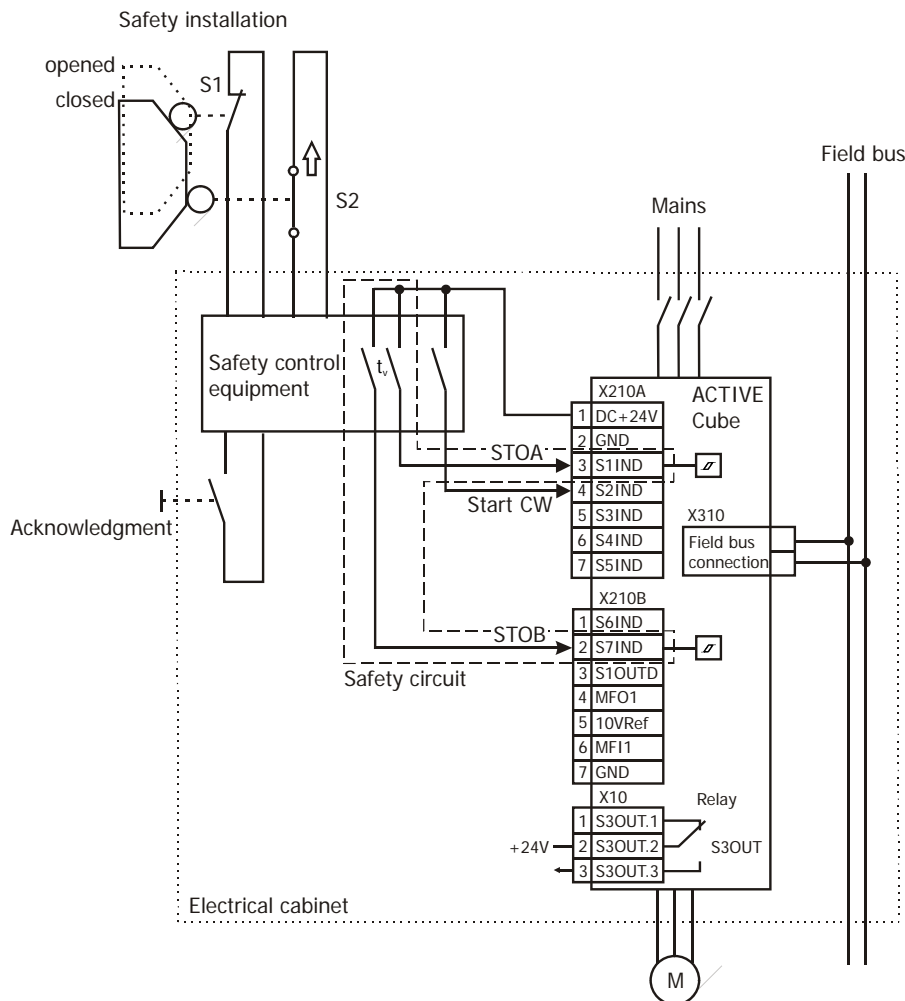

- STOA: first shutdown path of the safety function STO
- STOB: second shutdown path of the safety function STO
- X210A, X210B, X10: Control terminals of the frequency inverter
- X310: Interface of communication module
- +E20V: DC 20 V voltage output or input for an external DC 24 V voltage supply
- Terminal X210A.2 : Earth 20 V/ Earth 24 V (ext.)
- S1IND ... S7IND: Digital inputs
- S1OUTD: Digital output
- MFO1: Multi-function output (analog/digital, frequency signal)
- 10VRef: Reference voltage DC 10 V
- MF1: Multi-function input (analog/digital)
- Terminal 210B.7: Earth 10 V
- X10: Relay output
- ↑ Position switch displayed actuated
- t_v : time delay between signaling contact and shutdown contact

8.6 Group Stop, Stop Category 1

The application circuit shows a drive control system according to EN ISO 13849-1 PL d, IEC 61508 SIL 2 or EN 954-1 category 3 with a PLC connected via the field bus and safety module. A PLC performs the process control of the frequency inverter and can start the drive profiles via commands which are communicated through the field bus.

If the protective device is actuated, e.g. emergency stop switch, the enable paths of the safety module are interrupted. At first, the travel signal "Clockwise" is reset. Then, the motors are decelerated in a controlled way. After a delay t_v , the controller enable signal of the frequency inverters is interrupted via the disconnection of the control voltages from STOA and STOB and the integrated safe pulse block is activated.

Via the field bus, the (non-safe) feedback is transmitted to the PLC indicating that the drives have stopped. Except for the terminals shown in the diagram, no further terminals are required for connection.

The external DC 24 V supply must be dimensioned accordingly. For each STOA & STOB input, 14 mA must be available.

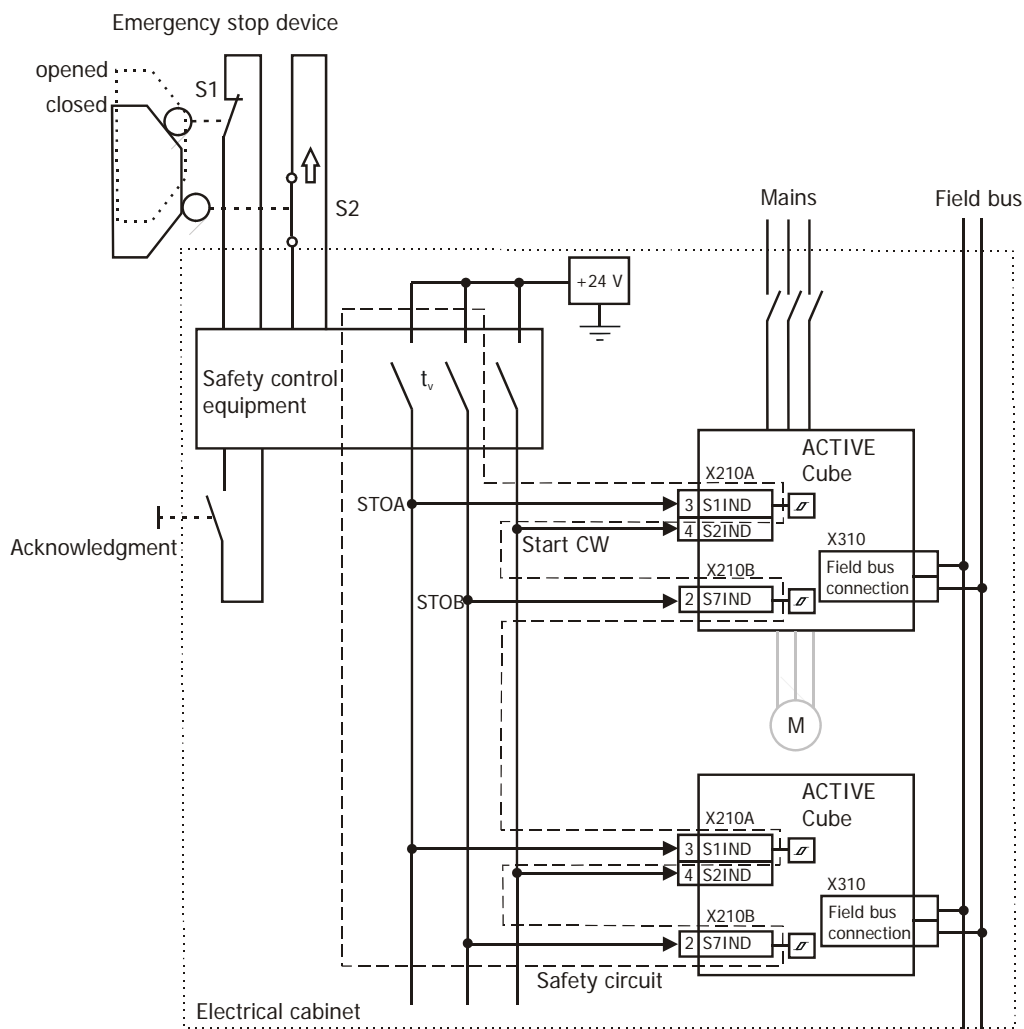

STOA: first shutdown path of the safety function STO
 STOB: second shutdown path of the safety function STO

↑ Position switch displayed actuated

t_v : time delay between signaling contact and shutdown contact

8.7 Error exclusion “short circuit” in the cabinet

The application circuit shows a drive control system according to EN ISO 13849 PL d, IEC 61508 SIL 2 or EN 954-1 category 3 with PLC and safety control equipment. Safety control equipment with one enable path and interconnection line is implemented instead of safety control equipment with two enable paths.

Comply with the following conditions:

- Safety control equipment and inverter have to be placed in the same cabinet.
- Error exclusion in case of short circuit has to be ensured for wiring between safety control equipment and inverter (for example insulated conductor).
- Blocking diodes have to be integrated into each path after separation of the STO inputs.

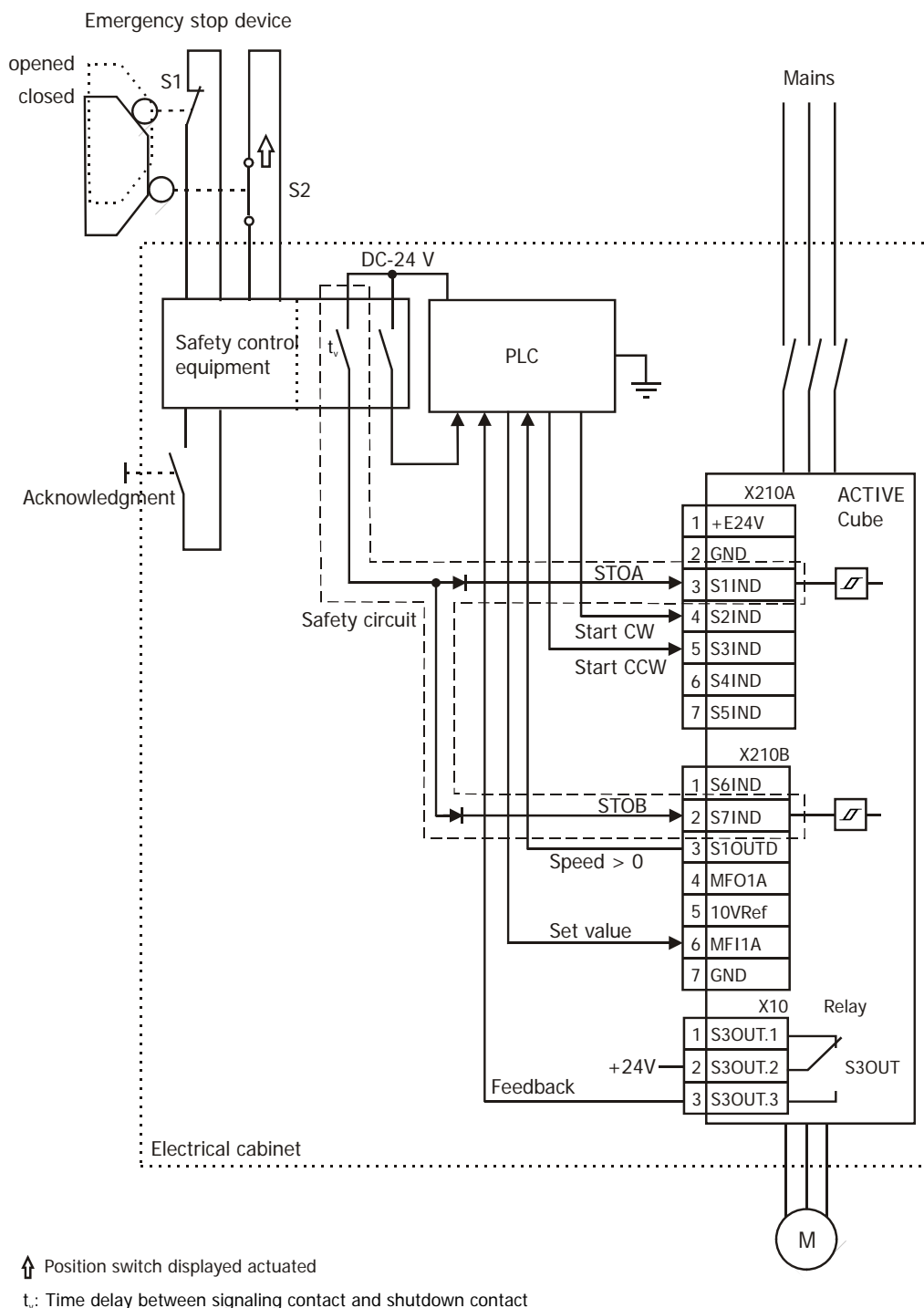

9 Checklist

This list provides an overview of the requirements to be met in installation, commissioning and operation of the safety function. Depending on the application, additional requirements must be met. Complete this list according to your application.

Risk analysis:

- was performed
- requires the use of the safety function “Safe Torque Off”
- requires category 3 according to the following classifications:
 - PL d (or smaller) according to EN ISO 13849-1
 - SIL 2 (or smaller) according to IEC 61508
 - Category 3 (or smaller) according to EN 954-1
- considers the stopping behavior of the ACTIVE Cube frequency inverter
- permits coasting of the drive to a standstill or requires the installation of a mechanical brake.
- considers the access time to the hazard area
- defines intervals for regular functional checks of the safety function

Installation:

- EMC instructions in the operating instructions considered?
- The shield of the 24 V power supply was connected on both sides.
- Emergency stop devices meet the following classifications:
 - PL d (or smaller) according to EN ISO 13849-1
 - SIL 2 (or smaller) according to IEC 61508
 - Category 3 (or smaller) according to EN 954-1
- Emergency Stop devices have a cross fault monitoring (2-channel connection) or protected wiring?
- It is ensured that resetting of the safety control device alone does not result in a restart of the drive.
- It is ensured that no voltage higher than DC 30 V can occur on the terminals of the control electronic unit (voltage resistance).

Commissioning:

- Functional check of safety function performed?
- Wiring of safety components checked?
- Acceptance report issued?

Operation:

- The safety function is checked regularly.

10 Safety Function Test Report

The concept relating to the safety function STO (Safe Torque Off) described in this manual was assessed and certified by Berufsgenossenschaftliches Institut für Arbeitsschutz (Trade Association Institute for Work Safety).

Test institute	Institut für Arbeitsschutz der Deutschen Gesetzlichen Unfallversicherung
Test report no.	200622803
Test sample	Frequency inverter of ACTIVE Cube series, concept inspection
Basis of test	DIN EN 61508 Parts 1-7:2002/2005 (as far as applicable)
	DIN EN ISO 13849-2:2003 (as far as applicable)
	EN 13849 -1:2006-11
	DIN EN 954-1:1997-03
	DIN EN 62061
	DIN EN 61800-5-1
	IEC 61800-5-2:2007
	DIN EN 61800-3
Assessment	Due to the realized error tolerance and the measures for error management, error prevention and error identification, the presented concept meets the requirements up to safety integrity level SIL 2 according to DIN EN 61508, category 3 according to DIN EN 954-1 as well as performance level d according to EN 13849-1.

11 STO status (diagnosis)

The actual value STO state 277 can be used for an extended diagnosis of the two inputs STOA and STOB. The states of the inputs are displayed bit coded.

Bit	Significance	Description
0	1	Input STOA missing
1	2	Input STOB missing
2	4	Input STOA switch off
3	8	Input STOB switch off
4	16	Timeout STOA
5	32	Timeout STOB
6	64	Diagnosis fault
7	127	FI fault (error)

12 Index of Change

ACU-STOV1-01SV2-02: Terminal designation of relay output X10 changed.

ACU-STOV1-00SV2-02: New Application example Fault exclusion "Short circuit" in electrical cabinet. Application examples 8.2 and 8.4 changed to display the usage of the digital output more precise.

ACU-STOV1-00SV2-01: Different supplements and more detailed descriptions

ACU-STOV1-00SV1-01: Changed DC-24 V into DC 24 V and DC-30 V into DC 30 V.

ACU-STOV1-00SV1-00: First issue



Bonfiglioli Worldwide & BEST Partners

AUSTRALIA

BONFIGLIOLI TRANSMISSION (Aust) Pty Ltd.
48-50 Adderley St. (East) Auburn (Sydney) N.S.W. 2144
Tel. (+61) 2 8748 4400 - Fax (+61) 2 9748 8740
P.O. Box 6705 Silverwater NSW 1811
www.bonfiglioli.com.au - bta1@bonfiglioli.com.au

AUSTRIA **BEST**

MOLL MOTOR GmbH
Industriestrasse 8 - 2000 Stockerau
Tel. (+43) 2266 63421+DW - Fax (+43) 6342 180
Tlx 61 32 22 348 Molla
www.mollmotor.at - office@mollmotor.at

BELGIUM **BEST**

N.V. ESCO TRANSMISSION S.A.
Culliganlaan 3 - 1831 Machelem Diegem
Tel. 0032 2 7204880 - Fax 0032 2 7212827
Tlx 21930 Escopo B
www.escotrans.be - info@escotrans.be

BRASIL **BEST**

ATI BRASIL
Rua Omlio Monteiro Soares, 260 - Vila Fanny - 81030-000
Tel. (+41) 334 2091 - Fax (+41) 332 8669
www.atibrasil.com.br - vendas@atibrasil.com.br

CANADA

BONFIGLIOLI CANADA INC.
2-7941 Jane Street - Concord, ONTARIO L4K 4L6
Tel. (+1) 905 7384466 - Fax (+1) 905 7389833
www.bonfigliolicanada.com - sales@bonfigliolicanada.com

CHINA

BONFIGLIOLI DRIVES (SHANGHAI) CO. LTD.
No. 8 Building, Area C1 - 318
SuHong Road, Qingpu, Shanghai 201700
Tel. +86 21 69225500 - Fax +86 21 69225511
www.bonfiglioli.cn - linkn@bonfiglioli.com

FRANCE

BONFIGLIOLI TRANSMISSIONS S.A.
Rue Eugène Pottier BP 19
Zone Industrielle de Moimont II - 95670 Marly la Ville
Tel. (+33) 1 34474510 - Fax (+33) 1 34688800
www.bonfiglioli.fr - btf@bonfiglioli.fr

GERMANY

BONFIGLIOLI DEUTSCHLAND GmbH
Hamburger Straße 18 - 41540 Dormagen
Tel. (+49) 2133 50260 - Fax (+49) 2133 502610
www.bonfiglioli.de - info@bonfiglioli.de

GREAT BRITAIN

BONFIGLIOLI UK Ltd
Unit 3 Colemeadow Road - North Moons Moat
Redditch, Worcestershire B98 9PB
Tel. (+44) 1527 65022 - Fax (+44) 1527 61995
www.bonfiglioli.co.uk - manwaha@bonfiglioli.com

BONFIGLIOLI (UK) LIMITED
5 Grosvenor Grange - Woolston - Warrington, Cheshire WA1 4SF
Tel. (+44) 1925 852667 - Fax (+44) 1925 852668
www.bonfiglioliuk.co.uk - sales@bonfiglioliuk.co.uk

GREECE

BONFIGLIOLI HELLAS
O.T. 48A T.O. 230 - C.P. 570 22 Industrial Area - Thessaloniki
Tel. (+30) 2310 796456 - Fax (+30) 2310 795903
www.bonfiglioli.gr - info@bonfiglioli.gr

HOLLAND **BEST**

ELSTO AANDRIJFTECHNIEK
Loosterweg, 7 - 2215 TL Voorhout
Tel. (+31) 252 219 123 - Fax (+31) 252 231 660
www.elsto.nl - imfo@elsto.nl

HUNGARY **BEST**

AGISYS AGITATORS & TRANSMISSIONS Ltd
2045 Törökbalint, Tó u.2. Hungary
Tel. +36 23 50 11 50 - Fax +36 23 50 11 59
www.agisys.hu - info@agisys.com

INDIA

BONFIGLIOLI TRANSMISSIONS PVT Ltd.
PLOT AC7-AC11 Sidco Industrial Estate
Thirumudivakkam - Chennai 600 044
Tel. +91(0)44 24781035 / 24781036 / 24781037
Fax +91(0)44 24780091 / 24781904
www.bonfiglioli.co.in - bonfig@vsnl.com

NEW ZEALAND **BEST**

SAECO BEARINGS TRANSMISSION
36 Hastie Avenue, Mangere
Po Box 22256, Otahuhu - Auckland
Tel. +64 9 634 7540 - Fax +64 9 634 7552
mark@saeco.co.nz

POLAND **BEST**

POLPACK Sp. z o.o. - Ul. Chrobrego 135/137 - 87100 Torun
Tel. 0048.56.6559235 - 6559236 - Fax 0048.56.6559238
www.polpack.com.pl - polpack@polpack.com.pl

RUSSIA **BEST**

FAM
57, Maly prospekt, V.O. - 199048, St. Petersburg
Tel. +7 812 3319333 - Fax +7 812 3271454
www.fam-drive.ru - info@fam-drive.ru

SPAIN

TECNOTRANS SABRE S.A.
Pol. Ind. Zona Franca sector C, calle F, n°6 08040 Barcelona
Tel. (+34) 93 4478400 - Fax (+34) 93 3360402
www.tecnotrans.com - tecnotrans@tecnotrans.com

SOUTH AFRICA

BONFIGLIOLI POWER TRANSMISSION Pty Ltd.
55 Galaxy Avenue, Linbro Business Park - Sandton
Tel. (+27) 11 608 2030 OR - Fax (+27) 11 608 2631
www.bonfiglioli.co.za - bonfigsales@bonfiglioli.co.za

SWEDEN

BONFIGLIOLI SKANDINAVIEN AB
Kontorsgatan - 234 34 Lomma
Tel. (+46) 40 412545 - Fax (+46) 40 414508
www.bonfiglioli.se - info@bonfiglioli.se

THAILAND **BEST**

K.P.T MACHINERY (1993) CO.LTD.
259/83 Soi Phiboovnes, Sukhumvit 71 Rd. Phrakonong-nur,
Wattana, Bangkok 10110
Tel. 0066.2.3913030/7111998
Fax 0066.2.7112852/3811308/3814905
www.kpt-group.com - sales@kpt-group.com

USA

BONFIGLIOLI USA INC
1000 Worldwide Boulevard - Hebron, KY 41048
Tel.: (+1) 859 334 3333 - Fax (+1) 859 334 8888
www.bonfiglioliusa.com
industrialsales@bonfiglioliusa.com
mobilesales@bonfiglioliusa.com

VENEZUELA **BEST**

MAQUINARIA Y ACCESORIOS IND.-C.A.
Calle 3B - Edif. Comindu - Planta Baja - Local B
La Urbina - Caracas 1070
Tel. 0058.212.2413570 / 2425268 / 2418263
Fax 0058.212.2424552
Tlx 24780 Maica V
www.maica-ve.com - maica@telcel.net.ve

HEADQUARTERS

BONFIGLIOLI RIDUTTORI S.p.A.
Via Giovanni XXIII, 7/A
40012 Lippo di Calderara di Reno

Tel. (+39) 051 6473111
Fax (+39) 051 6473126
www.bonfiglioli.com
bonfiglioli@bonfiglioli.com

SPARE PARTS BONFIGLIOLI

B.R.T.
Via Castagnini, 2-4
Z.I. Bargellino - 40012
Calderara di Reno - Bologna (ITALY)
Tel. (+39) 051 727844
Fax (+39) 051 727066
www.brtonfiglioliricambi.it
brt@bonfiglioli.com

ACTIVE Cube



www.bonfiglioli.com

 **BONFIGLIOLI**