

Application manual - Electronic gear

Position control and index control

ACTIVE Cube



General Information about the Documentation

This manual complements the configurations described in the operating instructions and the Quick Start Guide of the ACU 201 and ACU 401 frequency inverters. Configurations 115, 215, 415 and 515 additionally include the functions of an electronic gear with position controller. Configurations 116, 216 and 516 extend the functionality by the electronic gear with index controller.

For better clarity, the documentation is structured according to the customer-specific requirements made on the frequency inverter.

Quick Start Guide

The Quick Start Guide describes the basic steps required for mechanical and electrical installation of the frequency inverter. The guided commissioning supports you in the selection of necessary parameters and the software configuration of the frequency inverter.

Operating Instructions

The Operating Instructions describe and document all functions of the frequency inverter. The parameters required for adapting the frequency inverter to specific applications as well as the wide range of additional functions are described in detail.

Application Manual

The Application Manual contains additional information facilitating the installation and commissioning of the frequency inverter, i.e. information on the different issues relating to the specific application realized by the frequency inverter.

Installation Instructions

Complementing the Quick Start Guide and the Operating Instructions, the Installation Instructions provide information on how to install and use the additional/optional components.

If you need a copy of the documentation or additional information, contact your local representative of BONFIGLIOLI.

The following pictograms and signal words are used in the documentation:



Danger!

Danger refers to an immediate threat. Non-compliance with the precaution described will result in death, serious injury or material damage.



Warning!

Warning refers to a possible threat. Non-compliance with the warning may result in death, serious injury or material damage.



Caution!

Caution refers to an immediate hazard. Damage to people or property can be the result.

Attention!

Attention and the related text refer to a possible behavior or an undesired condition which can occur during operation.

Note

Note marks information which facilitates handling for you and supplements the corresponding part of the documentation.

TABLE OF CONTENTS

1	General Safety Instructions and Information on Use	3
1.1	General Information	3
1.2	Purpose of the Frequency Inverters	4
1.3	Transport and Storage	4
1.4	Handling and Installation	4
1.5	Electrical Connection	5
1.6	Information on Use	5
1.7	Maintenance and Service	5
2	Control Inputs and Outputs	6
2.1	Control Terminals	6
3	Commissioning of the Frequency Inverter	10
3.1	Switching on Mains Voltage	10
3.2	Setup Using the Control Unit	10
4	Electronic Gear	12
4.1	Scope of Functions	12
4.2	Operation Modes of Electronic Gear	13
4.3	Gear Factor	13
4.3.1	Setting a Fixed Gear Factor	13
4.3.2	Setting a Variable Gear Factor	14
4.4	Offset Switches	15
4.5	Reference value and actual value input	16
4.6	Position Control	17
4.7	Index Control	19
4.7.1	Scope sources	21
4.8	Actual Values	21
4.9	Adjustment Options	22
4.9.1	Frequency Inverter as Master	22
4.9.2	Frequency Inverter as Slave	23
4.10	Examples of wiring	25
5	Electronic gear via System bus	28
5.1	Speed Sensor Simulation	28
5.2	Adjustment Options	29
5.2.1	Frequency Inverter as Master	29
5.2.2	Slave Settings	30
5.3	Position Control via System Bus	31
6	Parameter List	32
6.1	Actual Value Menu (VAL)	32
6.2	Parameter Menu (PARA)	33

1 General Safety Instructions and Information on Use

The present documentation was prepared with great care and it was subjected to extensive and repeated reviews. For reasons of clarity, it was not possible to include all details of all the different types of the product in the documentation. Neither was it possible to consider all conceivable installation, operation or maintenance situations. If you require further information or if you meet with specific problems which are not dealt with in sufficient detail in the documentation, contact your local BONFIGLIOLI agent.

We would also like to point out that the contents of this documentation do not form part of any previous or existing agreement, assurance or legal relationship. Neither are they intended to supplement or replace such agreements, assurances or legal relationships. The manufacturer's obligations are exclusively specified in the relevant purchase contract. This contract also contains all and any warranty regulations which may apply to the relevant scope of supply. These contractual warranty provisions are neither extended nor limited by the specifications contained in this documentation.

The manufacturer reserves the right to correct or amend the specifications, product information and omissions in these operating instructions without notice. The manufacturer shall not be liable for any damage, injuries or costs which may be caused by the aforementioned reasons.



Warning! The specifications and instructions contained in the documentation must be complied with strictly during installation and commissioning. Only qualified staff who has read and understood the documentation is allowed to carry out installation or commissioning work or to operate the devices. The safety instructions must be complied with strictly. The term „Qualified Staff“ refers to anybody who is familiar with the installation, assembly, commissioning and operation of the frequency inverter and has the proper qualification for the job.

1.1 General Information



Warning! The DC-link circuit of the BONFIGLIOLI VECTRON frequency inverter is charged during operation, i.e. there is always the risk of contact with high voltage. Frequency inverters are used for driving moving parts and they may become hot at the surface during operation.

Any unauthorized removal of the necessary covers, improper use, wrong installation or operation may result in serious injuries or material damage.

In order to avoid such injuries or damage, only qualified staff may carry out the transport, installation, setup or maintenance work required. The standards EN 50178, IEC 60364 (Cenelec HD 384 or DIN VDE 0100), IEC 60664-1 (Cenelec HD 625 or VDE 0110-1), BGV A2 (VBG 4) as well as the applicable national regulations must be complied with. The term „Qualified Staff“ refers to anybody who is familiar with the installation, assembly, commissioning and operation of the frequency inverter as well as the possible hazards and has the proper qualification for the job.

1.2 Purpose of the Frequency Inverters



Warning! The frequency inverters are electrical drive components intended for installation in industrial plants or machines. Commissioning and start of operation is not allowed until it has been verified that the machine meets the requirements of the EC Machinery Directive 98/37/EEC and EN 60204. In accordance with the CE marking requirements, the frequency inverters also comply with the Low Voltage Directive 2006/95/EC as well as EN 50178/DIN VDE 0160 and EN 61800-2. The user shall be responsible for making sure that the requirements of the EMC Directive 89/336/EEC are met. Frequency inverters are only available at specialized dealers and are exclusively intended for professional use as per EN 61000-3-2. The frequency inverters are also marked with the UL label according to UL508c, which proves that they also meet the requirements of the CSA Standard C22.2-No. 14-95. The technical data, connection specifications and information on ambient conditions are indicated on the name plate and in the documentation and must be complied with in any case. Anyone involved in any kind of work at the device must have read the instructions carefully and understood them before starting the work.

1.3 Transport and Storage

The frequency inverters must be transported and stored in an appropriate way. During transport and storage the devices must remain in their original packaging. The units may only be stored in dry rooms which are protected against dust and moisture and are exposed to little temperature deviations only. Observe the climatic conditions according to EN 50178 and the marking on the packaging. The frequency inverters must not be stored for more than one year without connecting them to nominal voltage.

1.4 Handling and Installation



Warning! Damaged or destroyed components must not be put into operation because they may be a health hazard.

The frequency inverters are to be used in accordance with the documentation as well as the applicable directives and standards. They must be handled carefully and protected against mechanical stress. Do not bend any components or change the isolating distances. Do not touch any electronic components or contacts. The devices are equipped with components which are sensitive to electrostatic energy and can easily be damaged if handled improperly. Any use of damaged or destroyed components shall be considered as a non-compliance with the applicable standards. Do not remove any warning signs from the device.

1.5 Electrical Connection



Warning! Before any assembly or connection work, discharge the frequency inverter. Verify that the frequency inverter is discharged. Do not touch the terminals because the capacitors may still be charged. Comply with the information given in the operating instructions and on the frequency inverter label.

When working at the frequency inverters, comply with the applicable standards BGV A2 (VBG 4), VDE 0100 and other national directives. Comply with the electrical installation instructions given in the documentation as well as the relevant directives. The manufacturer of the industrial machine or plant is responsible for making sure that the limit values specified in the EMC product standard EN 61800-3 for electrical variable-speed drives are complied with.

The documentation contains information on EMC-conforming installation. The cables connected to the frequency inverters may not be subjected to high-voltage insulation tests unless appropriate circuitry measures are taken before.

1.6 Information on Use



Warning! The frequency inverter may be connected to power supply every 60 s. Consider this for a jog operation of a mains contactor. For commissioning or after an emergency stop, a non-recurrent, direct restart is permissible. After a failure and restoration of the power supply, the motor may start unexpectedly if the AutoStart function is activated. Install protective equipment if personal injury or material damage is possible. Before commissioning and the start of the operation fix all covers and check the terminals. Check the additional monitoring and protective devices according to EN 60204 and applicable the safety directives (e.g. Working Machines Act, Accident Prevention Directives etc.). No connection work may be performed, while the system is in operation.

1.7 Maintenance and Service



Warning! Unauthorized opening and improper interventions can lead to personal injury or material damage. Repairs on the frequency inverters may only be carried out by the manufacturer or persons authorized by the manufacturer. Check protective equipment regularly.

2 Control Inputs and Outputs

The modular structure of the frequency inverters enables a wide spectrum of applications on the basis of the available hardware and software functionality. The functionality of the control inputs and outputs described in the brief instructions and operating instructions is extended in the described configurations.



Caution! Switch off power supply before connecting or disconnecting the control inputs and outputs. Otherwise, components may be damaged.

- The unit may only be connected with the power supply switched off.
- Make sure that the frequency inverter is discharged.

2.1 Control Terminals

The connection diagrams describe the default assignment of control terminals and functions in the different configurations. According to the requirements of the application, the other functions can be assigned to the control terminals.

Configuration 115 – sensorless control with electronic gear and position control

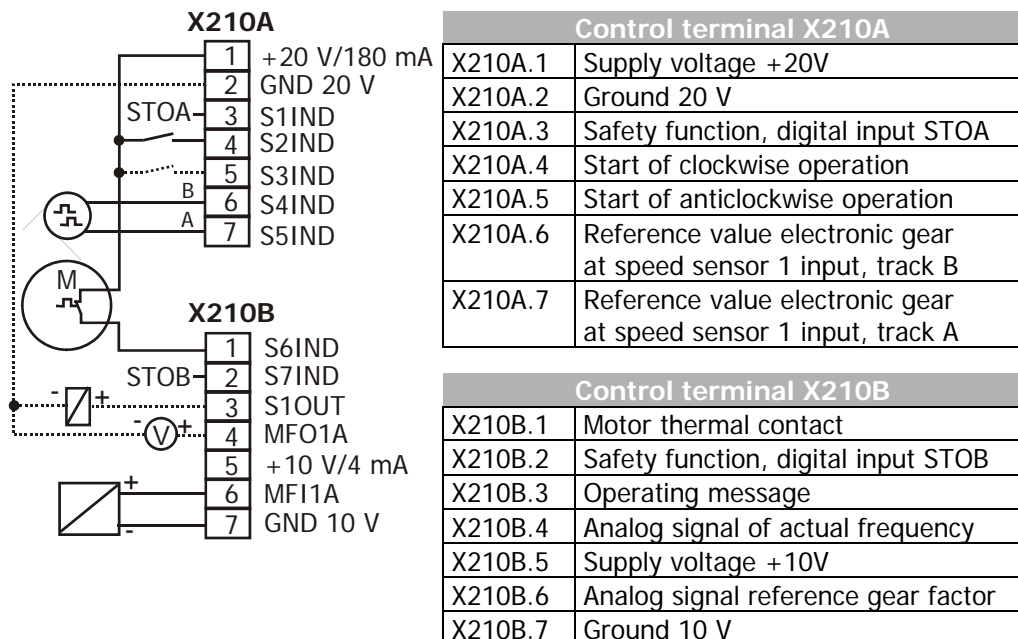

Configuration 116– sensorless control with electronic gear and index control

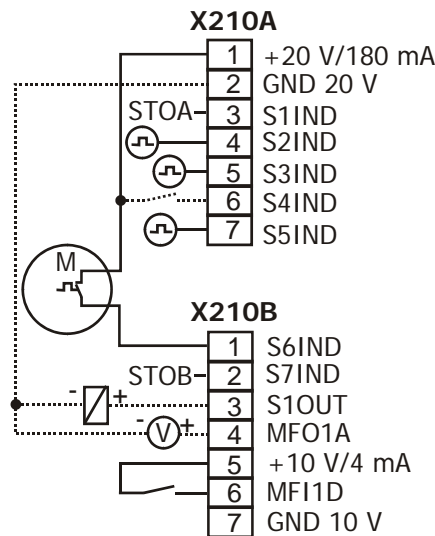

Control terminal X210A	
X210A.1	Supply voltage +20V
X210A.2	Ground 20 V
X210A.3	Safety function, digital input STO A
X210A.4	Index signal Master
X210A.5	Index signal Slave
X210A.6	Start of clockwise operation
X210A.7	Reference value electronic gear at speed sensor 1 input, track A

Control terminal X210B	
X210B.1	Motor thermal contact
X210B.2	Safety function, digital input STOB
X210B.3	Operating message
X210B.4	Analog signal of actual frequency
X210B.5	Supply voltage +10V
X210B.6	Index controller release
X210B.7	Ground 10 V

Configuration 215– field-oriented control with electronic gear and position control

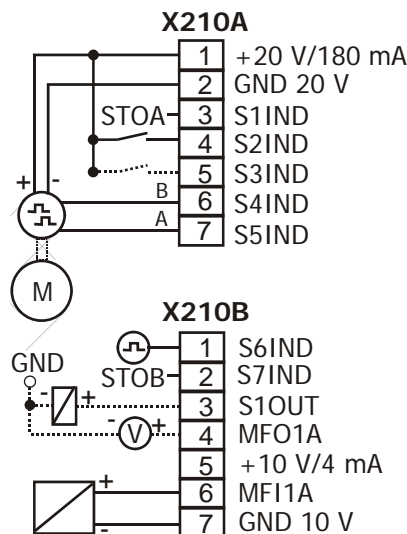

Control terminal X210A	
X210A.1	Supply voltage +20V
X210A.2	Ground 20 V
X210A.3	Safety function, digital input STO A
X210A.4	Start of clockwise operation
X210A.5	Start of anticlockwise operation
X210A.6	Speed sensor track B
X210A.7	Speed sensor track A

Control terminal X210B	
X210B.1	Repetition frequency input (reference value electronic gear)
X210B.2	Safety function, digital input STOB
X210B.3	Operating message
X210B.4	Analog signal of actual frequency
X210B.5	Supply voltage +10V
X210B.6	Analog signal reference gear factor
X210B.7	Ground 10 V

Configuration 216 – field-oriented control with electronic gear and index control

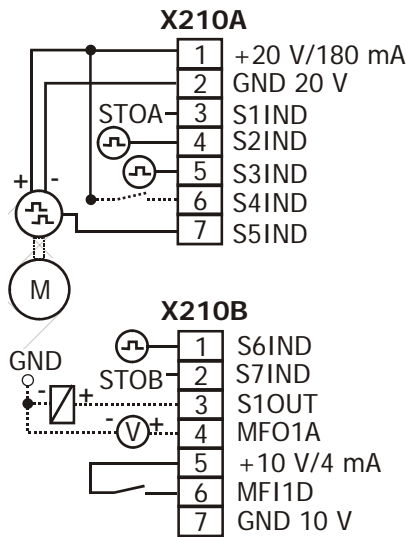

Control terminal X210A	
X210A.1	Supply voltage +20V
X210A.2	Ground 20 V
X210A.3	Safety function, digital input STOA
X210A.4	Index signal Master
X210A.5	Index signal Slave
X210A.6	Start of clockwise operation
X210A.7	Speed sensor track A

Control terminal X210B	
X210B.1	Repetition frequency input (reference value electronic gear)
X210B.2	Safety function, digital input STOB
X210B.3	Operating message
X210B.4	Analog signal of actual frequency
X210B.5	Supply voltage +10V
X210B.6	Index controller release
X210B.7	Ground 10 V

Note: In this configuration, generally only the simple or double evaluation of a track of a speed sensor is performed. This is to be considered during the parameterization.

Configuration 415 – sensorless field-oriented control with electronic gear and position control

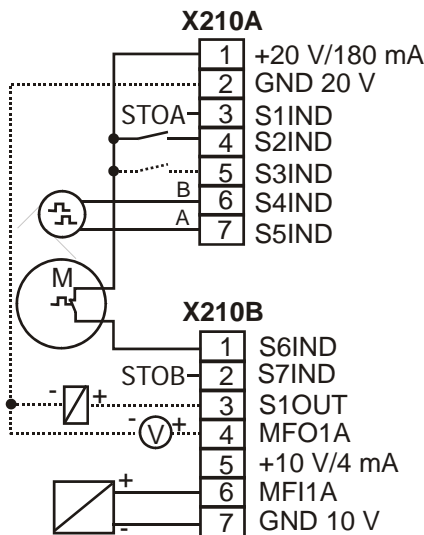

Control terminal X210A	
X210A.1	Supply voltage +20V
X210A.2	Ground 20 V
X210A.3	Safety function, digital input STOA
X210A.4	Start of clockwise operation
X210A.5	Start of anticlockwise operation
X210A.6	Reference value electronic gear at speed sensor 1 input, track B
X210A.7	Reference value electronic gear at speed sensor 1 input, track A

Control terminal X210B	
X210B.1	Motor thermal contact
X210B.2	Safety function, digital input STOB
X210B.3	Operating message
X210B.4	Analog signal of actual frequency
X210B.5	Supply voltage +10V
X210B.6	Analog signal reference gear factor
X210B.7	Ground 10 V

Configuration 515 – field-oriented control of a synchronous machine with electronic gear and position control

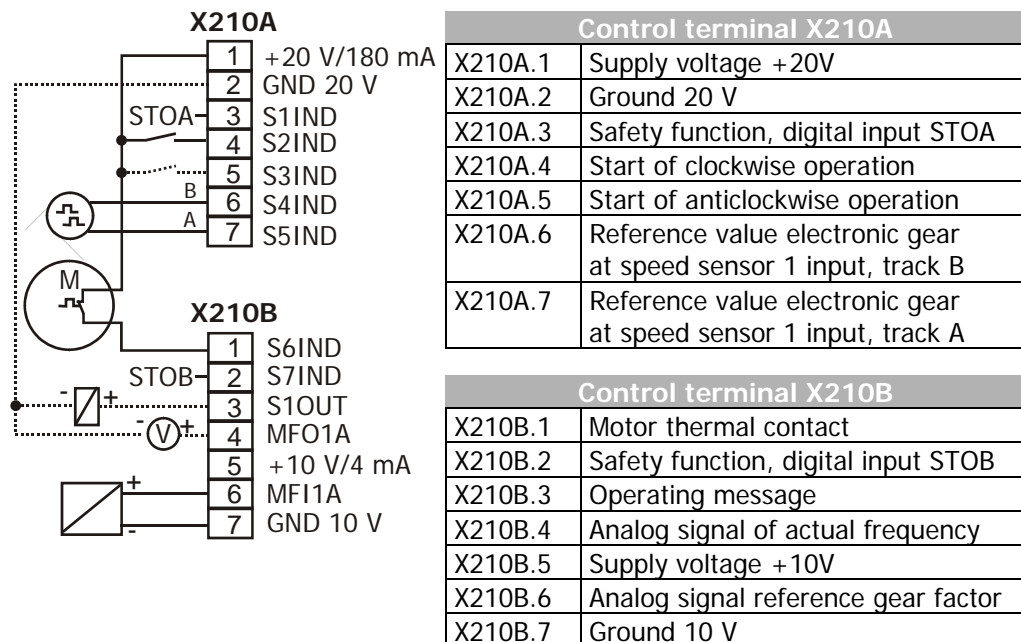

Note: For the operation of a synchronous machine, an expansion module for evaluating a resolver is required. This functionality is available with the modules of the EM-RES series.

Configuration 516 – field-oriented control of a synchronous machine with electronic gear and index control

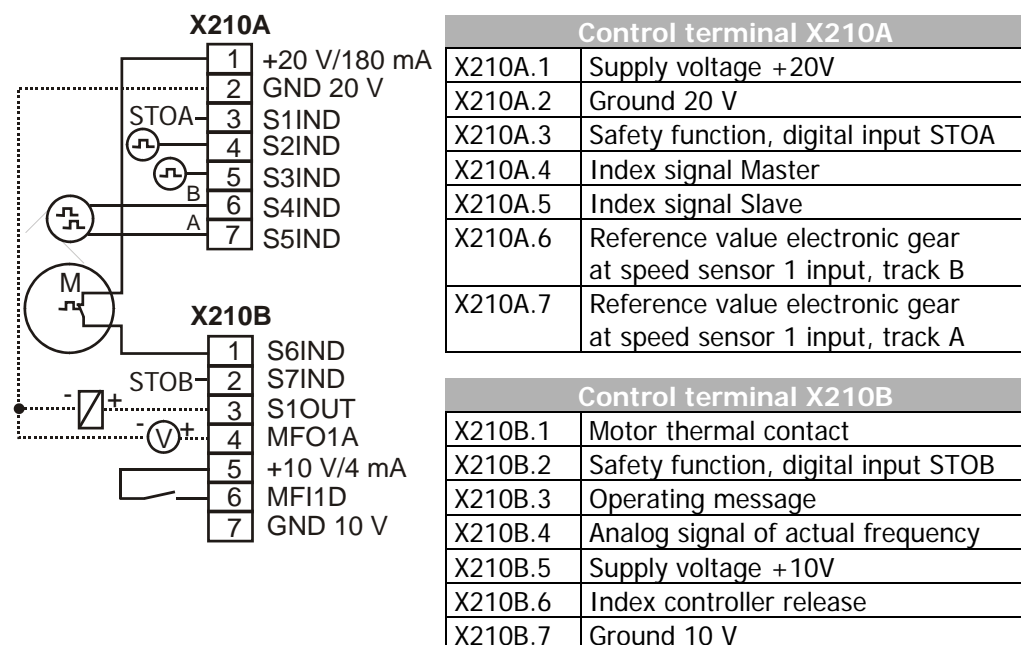

Note: For the operation of a synchronous machine, an expansion module for evaluating a resolver is required. This functionality is available with the modules of the EM-RES series.

3 Commissioning of the Frequency Inverter

3.1 Switching on Mains Voltage

After completion of the installation work, make sure to check all control and power connections again before switching on the mains voltage. If all electrical connections are correct, make sure that the frequency inverter is not enabled (control input S1IND open). After power-up, the frequency inverter carries out a self-test and the relay output (X10) reports "Fault".

After a few seconds, the self-test is complete, the relay (X10) picks up and signals "no fault".

If the unit is in "as-delivered" condition or after resetting the unit to the factory settings, the guided commissioning procedure is started automatically. On the control unit, the "SetUP" menu from the menu branch CTRL is displayed.

3.2 Setup Using the Control Unit



Caution! During the guided commissioning, comply with the safety instructions in chapter "General Safety Instructions and Information on Use" and in the Operating Instructions or the Brief Instructions.

Carry out the guided commissioning procedure of the frequency inverter for one of the configurations listed below. These contain the function of the electronic gear with position control or with index control.

Note: The guided commissioning contains the function for parameter identification. The parameters are determined by way of measurement and set accordingly. In the case of higher requirements as regards the accuracy of the speed/torque control, you should carry out the guided commissioning procedure once again **under operating conditions** because part of the machine data depends on the operating temperature.

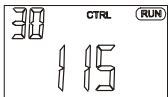

Configuration 115, sensorless control with electronic gear and position control

Configuration 115 extends the sensorless control of Configuration 110 by the functions of the electronic gear and a position controller.

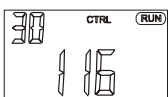

Configuration 116, sensorless control with electronic gear and index control

Configuration 116 extends the sensorless control of Configuration 110 by the functions of the electronic gear and an index controller.

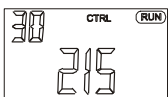

Configuration 215, field-oriented control with electronic gear and position control

Configuration 215 extends the field-oriented control of Configuration 210 by the functions of the electronic gear and a position controller.

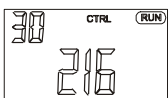

Configuration 216, field-oriented control with electronic gear and index control

Configuration 216 extends the field-oriented control of Configuration 210 by the functions of the electronic gear and an index controller.

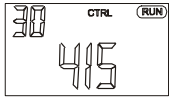

Configuration 415, sensorless field-oriented control with electronic gear and position control

Configuration 415 extends the sensorless field-oriented control of Configuration 410 by the functions of the electronic gear and a position controller.

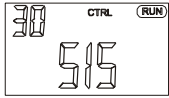

Configuration 515, field-oriented control of a synchronous machine with electronic gear and position control

Configuration 515 includes the sensorless field-oriented control of a synchronous machine and the functions of the electronic gear and a position controller.

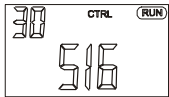

Configuration 516, field-oriented control of a synchronous machine with electronic gear and index control

Configuration 516 includes the sensorless field-oriented control of a synchronous machine and the functions of the electronic gear and an index controller.

4 Electronic Gear

The electronic gear enables the synchronization of drives without mechanical transmission elements such as shafts or clutches. The reference value for the Slave is the repetition frequency determined by the Master. This value can be multiplied by a gear factor. The transmission from the Master to the Slave is done via a repetition frequency signal or via System Bus.

The gear factor can be set permanently or varied during operation via freely configurable digital and analog signal sources through the percentage reference channel.

4.1 Scope of Functions

- Electronic gear
- Reference value via repetition frequency input, speed sensor 1 input, speed sensor 2 input of an expansion module EM-ENC/EM-IO or via System Bus
- Gear factor, numerator and denominator can be set separately
- Gear factor can be scaled during the operation
- Offset frequencies can be added depending on digital signals
- Position control, relative angle ratio of the drives adjustable
- Index control for exact control of synchronization of drives

Note: For the transmission of the repetition frequency value from the Master to the Slave via System Bus, an optional expansion module with System Bus interface is required.

4.2 Operation Modes of Electronic Gear

Via parameter *Operation Mode 689* for the electronic gear, you can determine if the gear factor is to be set permanently or to be scaled via a signal source, e.g. an analog input signal at the Slave. The repetition frequency of the Master is multiplied by the gear factor. Via parameter *Operation Mode 689* you can activate a position controlling in configurations 115, 215, 415 and 515.

<i>Operation mode 689</i>	Function
0 - Frequency Reference Channel	Reference value specification for the Slave is done via the <i>Reference Frequency Source 475</i> of the frequency reference channel. The electronic gearbox is deactivated.
1 - Fixed	The repetition frequency value specified via the repetition frequency input is multiplied by the gear factor and is the reference frequency for the Slave. The gear factor is calculated from the values of parameters <i>Gear Factor Numerator 685</i> and <i>Gear Factor Denominator 686</i> .
2 - Numerator Analog Numerator	Like operation mode 1, but the numerator of the gear factor is scaled via the <i>Reference Percentage Source 476</i> .
3 - Denominator Analog Denominator	Like operation mode 1, but the denominator of the gear factor is scaled via the <i>Reference Percentage Source 476</i> .
11 - Fixed with position controller	Like operation mode 1. Additionally, the relative angle position which the Slave drive is to have in relation to the Master is controlled. The gear factor is taken into account.

4.3 Gear Factor

The gear factor can be set permanently or scaled via the *Reference Percentage Source 476* during operation. In the factory settings, the gear factor can be set during operation, in configurations 115, 215, 415 and 515, via an analog voltage signal at multi-function input MF11A. This enable the realization of applications which require an adjustment of the transmission ratio during operations, e.g. winding machines or applications with tension control.

4.3.1 Setting a Fixed Gear Factor

Via parameters *Gear Factor Numerator 685* and *Gear Factor Denominator 686*, the gear factor is set permanently at the frequency inverter of the Slave drive.

$$\text{Gear Factor} = \frac{\text{Gear Faktor Numerator } \mathbf{685}}{\text{Gear Faktor Denominator } \mathbf{686}}$$

Parameter		Settings		
No.	Description	Min.	Max.	Fact. sett.
685	Gear Factor Numerator	-300.00	300.00	1.00
686	Gear Factor Denominator	0.01	300.00	1.00

4.3.2 Setting a Variable Gear Factor

Via parameters *Analog Factor Max.* **687** and *Analog Factor Min.* **688** the gear factor range is scaled if operation mode 2 or 3 is selected for parameter *Operation Mode* **689**. The scaling is done via the *Reference Percentage Source* **476** via which the signal sources for determining the reference value are selected. With the signal source selected, e.g. an analog signal at the multifunction input MF11A, the gear factor can be changed during operation.

Parameter		Settings		
No.	Description	Min.	Max.	Fact. sett.
687	Analog Factor Max.	0.00	3.00	1.20
688	Analog Factor Min.	0.00	3.00	0.80

Signal flow diagram for scaling the gear factor via the reference percentage source:

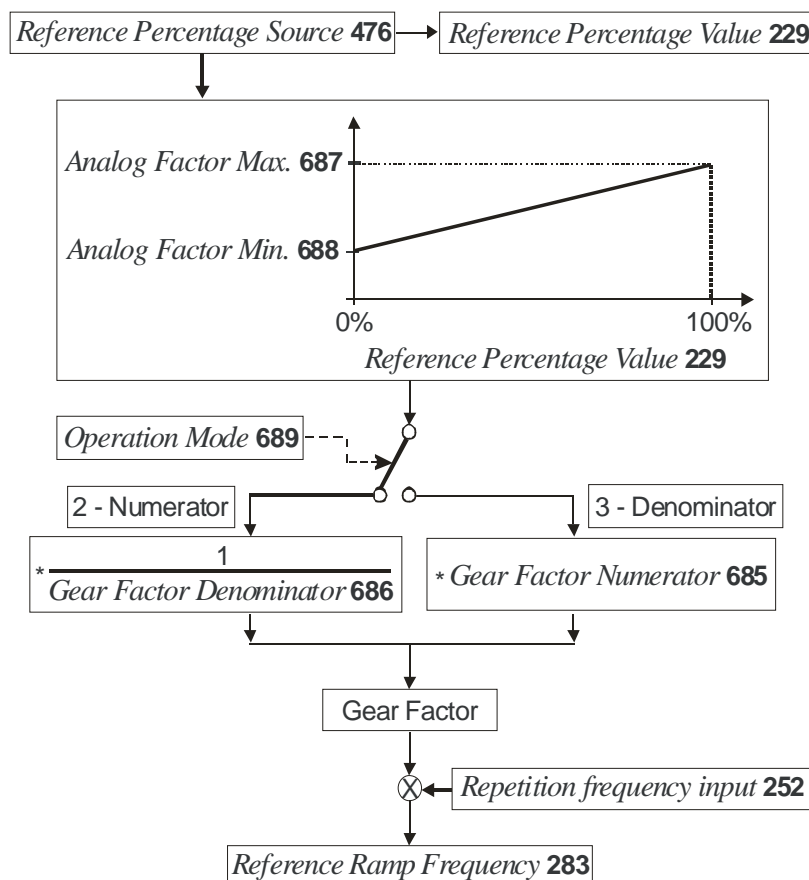

Example:

In an application, a Slave drive is to follow a Master drive, with the speed of the Slave having to be increased continuously without changing the speed specified by the master. The gear factor control is to be done using an analog voltage signal (0...10 V).

Suggested parameterization:

- Via parameter *Operation Mode* **689**, set operation mode "2 – Numerator Analog" for the electronic gear for a change of the gear factor by the numerator.
- Set the minimum and maximum limit for the numerator value via parameters *Analog Factor Max.* **687** and *Analog Factor Min.* **688**.

- Set the *Gear Factor Denominator* **686** to the required value.
- Set multifunction input MFI as an analog voltage input by adjusting *Operation Mode* **452** to "1 – voltage Input".
- For the *Reference Percentage Source* **476**, select an operation mode which contains MFI1A as a reference value source, e.g. operation mode "11 – +/- MFI1A + FP".

In this example, the default settings for *Analog Factor Max.* **687** and *Analog Factor Min.* **688**, an adjusted gear factor denominator of 2 and a reference percentage of 75% will result in a gear factor numerator of 1.1 and a reference frequency for the Slave of $10 \text{ Hz} * 1.1 / 2 = 5.5 \text{ Hz}$.

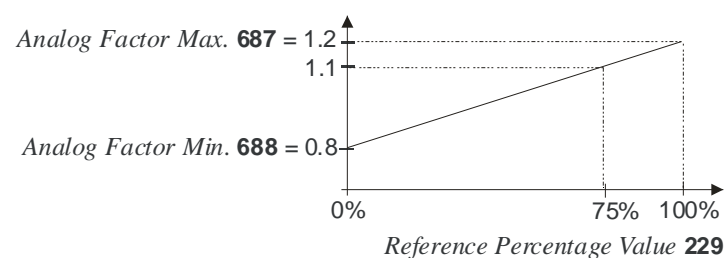

4.4 Offset Switches

Via the parameters *Offset Switch 1* **132** and *Offset Switch 2* **133**, you can select additional fixed frequencies which are added to the reference frequency. Digital signals at the control inputs or internal logic signals can be assigned to the parameters. The function is activated by these signals.

Note: While one of the offset switches is activated in operation mode "11 – fixed with position control" for parameter *Operation Mode* **689** and thus the fixed frequency is switched on, the position controller is switched off.

Via the logic statuses of *Offset Switch 1* **132** and *Offset Switch 2* **133**, you can select *Fixed Frequency 5* **485** and *Fixed Frequency 6* **486**.

Fixed Frequency Control		
<i>Offset Switch 1</i> 132	<i>Offset Switch 2</i> 133	Function/active fixed value
0	0	no additional fixed frequencies active
1	0	<i>Fixed Frequency 5</i> 485
0	1	<i>Fixed Frequency 6</i> 486
1	1	<i>Fixed Frequency 5</i> 485 + <i>Fixed Frequency 6</i> 486

0 = contact open, 1 = contact closed

4.5 Reference value and actual value input

The following inputs of the slave frequency inverter can be used for reference frequency transmission from master to slave. The actual value input receives the actual speed from the slave speed sensor.

Frequency inverter without expansion module ⁽³⁾		
Configuration	Reference value input	Actual value input
115 116	Speed sensor 1 ⁽¹⁾ or Repetition frequency input	-
215 216	Repetition frequency input ⁽¹⁾	Speed sensor 1 ⁽¹⁾
415	Speed sensor 1 ⁽¹⁾ or Repetition frequency input	-
Frequency inverter with expansion module EM-ENC or EM-IO		
Configuration	Reference value input	Actual value input
115 116	Speed sensor 1 ⁽¹⁾ or Speed sensor 2 or Repetition frequency input	-
215 216	Repetition frequency input ^{(1), (2)} or Speed sensor 1 or Speed sensor 2	Speed sensor 1 ⁽¹⁾ or Speed sensor 2
415	Speed sensor 1 ⁽¹⁾ or Speed sensor 2 or Repetition frequency input	-
Frequency inverter with expansion module EM-RES		
Configuration	Reference value input	Actual value input
515 516	Speed sensor 1 ⁽¹⁾ or Repetition frequency input	Resolver input ⁽¹⁾

⁽¹⁾ Factory setting.

Additional Note for Configuration 116 and 216: The factory setting "Speed sensor 1" is only set to track A.

⁽²⁾ Parameterisation of the repetition frequency input is not possible, if an expansion module EM-ENC-01 is connected. Use speed sensor 1 input or speed sensor 2 input.

⁽³⁾ Communication modules CM are not taken into consideration by this distinction.

Parameterisation of the inputs:

Speed sensor 1 input:

Parameter *Operation Mode* **490**

Parameter *Division Marks* **491**

Speed sensor 2 input ⁽¹⁾:

Parameter *Operation Mode* **493**

Parameter *Division Marks* **494**

Parameter *Level* **495**

Repetition frequency input:

Parameter *Operation Mode* **496**

Parameter *Divider* **497**

⁽¹⁾ Parameterisation is possible, if an expansion module EM-ENC or EM-IO is connected.

The factory settings of electronic gear configurations provide reference value inputs. If other inputs are required, for example speed sensor 2 input of an expansion module, loading of XPI files to the **software VPlus** is necessary. These files include additional parameters. For instance file swc215.xpi must be loaded, if configuration 215 is adjusted.

If the XPI file is loaded the parameter *El. Gear Reference Frequency* **125** can be adjusted for the reference value input of the electronic gear. Practical settings for operation without optional System bus are:

Operation mode	Function
80 - Freq. Speed Sensor 1	Reference value source is the speed sensor 1 frequency signal.
81 - Freq. Speed Sensor 2	Reference value source is the speed sensor 2 frequency signal.
288 - Repetition Frequency Input	Reference value source is the frequency signal at the repetition frequency input.

Note: It is possible to use Systembus values as reference value. Change the parameter *El. Gear Reference Frequency* **125** accordingly to the Systembus PDO, which receives the reference value.

4.6 Position Control

Activation of the overriding position control for the electronic gear is particularly useful if a synchronization without drift between the Master and the Slave is required for longer periods of time. Inaccuracies which result from rounding errors in the calculation of the gear factor are eliminated. Additionally, an offset angle relative to the master drive can be set at the slave drive.

The reference value for the position controller is specified via the repetition frequency input or the speed sensor input of the slave or via the System Bus.

To enable position control, operation mode "11 – fixed with position control" must be selected for parameter *Operation Mode* **689**.

If an XPI file x15 is loaded to the **software VPlus**, e.g. swc215.xpi for the configuration 215, you can adjust parameter *Position Reference Value* **147** to the reference value source for the position control. Practical settings for operation without optional System bus are:

Operation mode	Function
82 - Position Speed Sensor 1	Reference value source is the speed sensor 1 input.
83 - Position Speed Sensor 2	Reference value source is the speed sensor 2 input.

Via parameter *Position Actual Value* **148**, you can adjust the actual value source for the position control. Practical settings for operation without optional System bus are:

Operation mode	Function
82 - Position Speed Sensor 1	Actual value source is the speed sensor 1 input.
83 - Position Speed Sensor 2	Actual value source is the speed sensor 2 input.

Example for parameterisation:

Reference frequency value at speed sensor 1 input
 Speed sensor feedback at speed sensor 2 input (expansion module required)

Parameter *Operation mode* **689** = 11 - Fixed with position controller
 Parameter *El. Gear Reference Frequency* **125** = 80 - Freq. Speed Sensor 1
 Parameter *Position Reference Value* **147** = 82 - Position Speed Sensor 1
 Parameter *Position Actual Value* **148** = 83 - Position Speed Sensor 2

Via parameter *Amplification Position Controller 696*, the dynamism of the position controller is adjusted and the position error is assessed.

Parameter		Settings		
No.	Description	Min.	Max.	Fact. sett.
696	Amplification Position Controller	0.00%	200.00%	10.00%

Via parameter *Lim. Position Deviation 697*, you can adjust the maximum angle on which the Slave drive is yet to catch up during the compensation of a position error. The Slave drive cannot follow large jumps of the reference value directly due to the startup time. The startup time depends on the moment of inertia of the drive and the adjusted ramp gradients (acceleration and deceleration). If, for example, the drive has a deviation of 36 000° (i.e. 100 revolutions) from the reference value, the limitation of the position error must be set to values greater than or equal to 36 000° if the drive is to catch up on this deviation from the reference value again. However, the Slave does not try to catch up on values exceeding the *Lim. position deviation 697*.

Parameter		Settings		
No.	Description	Min.	Max.	Fact. sett.
697	Lim. Position Deviation	0°	99 999°	99 999°

Via parameter *Lim. Position Controller 698*, you can adjust the maximum output frequency of the position controller.

Parameter		Settings		
No.	Description	Min.	Max.	Fact. sett.
698	Lim. Position Controller	0.00 Hz	1000.00 Hz	1.00Hz

Via parameter *Position Correction 699*, you can adjust an offset angle of the Slave relative to the Master. This parameter can be written while the frequency inverter is in operation.

Parameter		Settings		
No.	Description	Min.	Max.	Fact. sett.
699	Position Correction	-3200.0°	3200.0°	-

4.7 Index Control

The electronic gearbox with index control is available in configurations 116, 216 and 516. Via index control, deviations from synchronous running which are due to process changes can be detected directly in the process by sensors and compensated by the index controller. The sensors detect reference points of the Master drive and the Slave drive and produce the index signals from these reference points. The time difference between the index signals resulting from the different position of the drives is compensated, thus the drives are synchronized.

Note: The connection of the index signals is described in chapter 2.1 "Control Terminals".

Example: Synchronous running of transport conveyors

The transported material is conveyed from one conveyor to the next and taken along by cams which serve as reference marks. The position of the reference marks is detected by sensors which supply the index signals for controlling the synchronous operation. The Slave drive is accelerated or decelerated depending on the time difference between the index signals from the Master and the Slave. Synchronous operation is restored as soon as the time difference is compensated, i.e. the reference marks of the Master and the Slave are detected by the sensors at the same time.

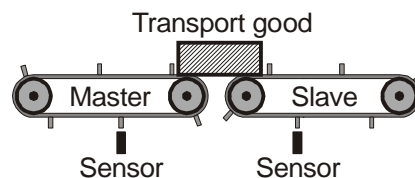

Index Control Principle:

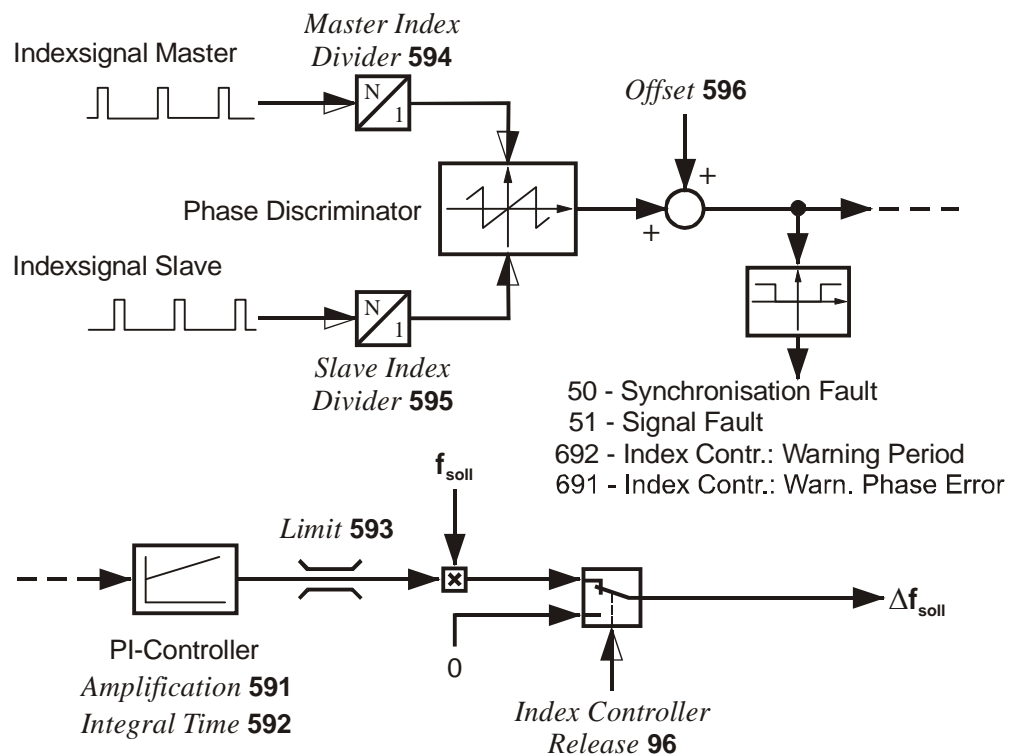

Via parameter *Operation Mode* **598**, the index controller is switched on or off permanently depending on the signal state at a digital input.

<i>Operation mode</i> 598	Function
0 - Off	The index controller is switched off permanently.
1 - On	The index controller is switched on permanently.
2 - Controlled by Contact	The index control is switched on or off via a digital input.

For contact control, a digital input can be selected and assigned to parameter *Index Controller Release* **96**. By default, multifunction input MF11D which is configured as a digital input is assigned to this parameter in configurations 116, 216 and 516.

A PI controller supplies the percentage value which acts on the reference value of the electronic gear. Via parameters *Amplification* **591** and *Integral Time* **592**, you can adjust the proportional and the integrating part of the index controller.

The maximum percentage value of the output signal of the controller can be adjusted via parameter *Limit* **593**, thus the dynamism of the controller can be influenced.

Parameter		Settings		
No.	Description	Min.	Max.	Fact. sett.
591	Amplification	0.0	100.0	1.0
592	Integral Time	0.0 ms	60.000 ms	1000 ms
593	Limit	0.00%	200.00%	10.00%

Parameters *Master Index Divider* **594** and *Slave Index Divider* **595** enable index control at different numbers of reference marks and thus different frequencies of the index signals for the Master and the Slave. The parameters can be adjusted according to the number of Master reference marks / number of Slave reference marks ratio.

Parameter		Settings		
No.	Description	Min.	Max.	Fact. sett.
594	Master Index Divider	1	65 535	1
595	Slave Index Divider	1	65 535	1

Attention! When setting parameters *Master Index Divider* **594** and *Slave Index Divider* **595**, note that the period of the divided index signals must at least be 16 ms since this is the response time of the digital inputs.

Via parameter *Offset* **596**, you can correct the position of the Slave relative to the Master.

Parameter		Settings		
No.	Description	Min.	Max.	Fact. sett.
596	Offset	-50.00%	50.00%	0.00%

Via parameter *Warning Limit 597*, you can monitor the phase displacement of the index signals from the Master and the Slave. A setting of e.g. 50% means that a warning is issued if the displacement between the index signals exceeds 50% of the period.

Parameter		Settings		
No.	Description	Min.	Max.	Fact. sett.
597	Warning Limit	0.00%	50.00%	0.00%

Note: The parameter *Warning Limit 597* should be set if an early warning of asynchronous behavior of the Master drive and the Slave drive is to be issued.

The warning messages due to a phase error or if the index signal period is too short can be assigned to a digital output.

Operation mode	Function
50 - Synchronization Fault	The phase error exceeded the <i>Warning Limit 597</i> .
51 - Signal Fault	Index signal period too short
150 and 151	Operation modes inverted

The following operation modes are available as signal sources for further linking to digital inputs.

Operation mode	Function
691 - Index Contr.: Warn. Phase Error	The phase error exceeded the <i>Warning Limit 597</i> .
692 - Index Contr.: Warning Period	Index signal period too short.

4.7.1 Scope sources

For the VPlus Scope function two dedicated sources are available.

693 – Master Index

694 – Slave Index

These sources will display the inputs at the two corresponding digital inputs “Index Signal Master” (S2IND) and “Index Signal Slave” (S3IND).

4.8 Actual Values

Via parameter *Repetition Frequency Input 252*, you can display the actual value of the repetition frequency input.

Via parameter *Freq. Speed Sensor 1 217*, you can display the frequency reference value or the actual frequency value of the speed sensor 1 input, dependent on the use as reference value input or input for speed sensor feedback.

Via parameter *Freq. Speed Sensor 2 219*, you can display the frequency reference value or the actual frequency value of the speed sensor 2 input, dependent on the use as reference value input or input for speed sensor feedback. Speed sensor 2 input is available if an expansion module EM-ENC or EM-IO is connected.

Via parameter *Reference Ramp Frequency 283*, the actual value of the frequency after multiplication by the gear factor and addition of the optionally selectable repetition frequencies can be displayed. This parameter is available if a communication module CM-232/485 or CM-CAN is connected.

4.9 Adjustment Options

The following instructions describe options for setting the electronic gear and the position controller. The settings must be adjusted to the application. For further information on the parameterization of the repetition frequency inputs and outputs, refer to the operating instructions. For information on the parameterization of the System Bus, refer to the instructions of the expansion modules with System Bus.

Attention! The control functions listed in the following table may affect the synchronous operation of the drives. It should be checked if these additional control functions are switched on and if they are required.

Parameter	Function
573 Operation Mode	Intelligent current limits
610 Operation Mode	Current limit value controller
660 Operation Mode	Slip compensation
670 Operation Mode	Voltage controller
720 Operation Mode	Speed controller

Via parameter *Controller Status* **275** you can display if a controller is active.

The function of the electronic gear is realized by configuring a digital input of the Slave frequency inverter as a repetition frequency input. If a frequency inverter is the Master, the repetition frequency output of the Master frequency inverter or of an expansion module is used.

Note: Connect the inverter according to the instructions and connection diagrams in chapter "Control Inputs and Output".

4.9.1 Frequency Inverter as Master

If a frequency inverter is configured as Master of the electronic gear, the following settings (examples) can be made for the transmission of the repetition frequency.

- If not yet done after commissioning, select a configuration for parameter *Configuration* **30**, e.g. Configuration "210 – speed-controlled field-oriented control" for speed control of the Master drive with speed sensor feedback. Depending on the application, another configuration can be selected, too.
- If a configuration with speed sensor feedback is selected you should check if the speed sensor monitoring is switched on. In this way, faulty speed sensor signals can be detected. Speed sensor monitoring is activated by default. By selecting operation mode "2 – Error" for parameter *Operation Mode* **760**, you can switch on the speed sensor monitoring.
- Select operation mode "3 – Repetition Frequency" for parameter *Operation Mode* **550** of the multifunction output MFO1. As a result, the multifunction output is used as a repetition frequency output.

- Select an operation mode for parameter *Repetition frequency Mode* **555**, e.g. Operation Mode "3 – Frequency Speed Sensor 1", for the Master drive with speed sensor feedback. In this operation mode, the speed of the Slave drive follows the speed of the Master drive at the highest accuracy. Depending on the application, you can also choose another operation mode for *Repetition Frequency Mode* **555**.

Note: Parameter *Repetition Frequency Mode* **555** is not available for the expansion modules with resolver interface EM-RES. The number of division marks is set permanently to 1024.

The expansion module is equipped with a two-channel repetition frequency output for push-pull operation (TTL).

- Set the value for parameter *Division Marks* **556** according to the required frequency at the repetition frequency output. This is the number of pulses per motor revolution for the repetition frequency. The pulse duration depends on the motor speed. By default, this parameter is set to 1024. When making the settings, take the frequency limit of the frequency output of 150 kHz into account. The maximum value S_{\max} which can be set for parameter *Division Marks* **556** is:

$$S_{\max} = \frac{150\,000 \text{ Hz}}{\text{absolute frequency}}; \quad \text{Division Marks } \mathbf{556} * \frac{\text{motor speed}}{\text{Gear Factor}} \leq 150 \text{ kHz}$$

4.9.2 Frequency Inverter as Slave

For the function of the electronic gear via the repetition frequency, the following settings (examples) can be made at the frequency inverter of the Slave drive.

- If not done yet after the commissioning, select one of the configurations with electronic gear for parameter *Configuration* **30**, e.g. Configuration "215 – speed-controlled field-oriented control with electronic gear". Depending on the application, another configuration with electronic gear can be selected, too.
- For parameter *Operation Mode* **496**, select the digital input for the repetition frequency and the type of evaluation, e.g. "62 – S6IND Double Evaluation pos."
- Since the rated speed decreases when the number of pole pairs is higher ($n-1/p$), different speeds may result if the Master and Slave have the same reference frequencies. Adjust the values for parameters *Divider* **497** of the repetition frequency input of the Slave and *Division Marks* **556** of the repetition frequency output of the Master according to the number of pole pairs of the motors in order to obtain the same speeds for the Master drive and the Slave drive. Different speeds can be realized by setting the gear factor, as described in chapters "Setting a Fixed Gear Factor" and "Setting a Variable Gear Factor".

Different values for parameters *Divider* **497** of the repetition frequency input of the Slave and *Division Marks* **556** of the repetition frequency output of the Master result in different speeds of the Master drive and the Slave drive if the number of pole pairs of the motors is the same.

- If a configuration with speed sensor feedback is selected, check if the speed sensor monitoring is switched on. In this way, faulty speed sensor signals can be detected. Speed sensor monitoring is activated by default. By selecting operation mode "2 – Error" for parameter *Operation Mode* **760**, you can switch on the speed sensor monitoring.
- Set parameters *Acceleration (Clockwise)* **420** and *Deceleration (Clockwise)* **421** or *Acceleration Anticlockwise* **422** and *Deceleration Anticlockwise* **423** to the required values. For synchronous acceleration and deceleration of the drives, set the values of the Slave slightly higher than the values of the Master. These increased values are to ensure that the Slave drive can follow the Master drive in dynamic operation cases.
- For a synchronous start of the Master drive and the Slave drive, set the *Minimum Frequency* **418** of the Slave to 0 in order to prevent a premature start of the Slave drive if the controller release signal is present at S1IND.
- Select an *Operation Mode* **689** and adjust the required transmission ratio via parameters *Gear Factor Numerator* **685** and *Gear Factor Denominator* **686**.

Attention! In order to avoid time delays during the processing of the repetition frequency, the Slave frequency inverter should be released before the Master frequency inverter.

4.10 Examples of wiring

Example 1: Transmission of the reference frequency value without information about direction of rotation

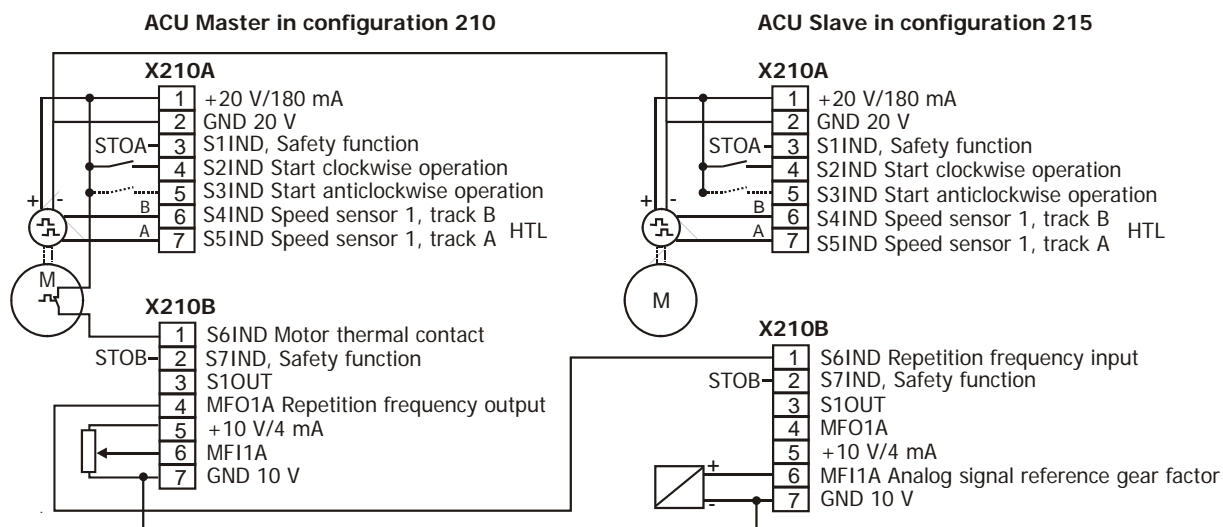

To ensure correct operation, connect the GND terminals between the frequency inverters.

Overview of Parameter Setting Examples:

Parameter		Setting/Selection
Master Settings		
30	Configuration	210 – speed-controlled field oriented control
420	Acceleration (Clockwise)	5 Hz/s
421	Deceleration (Clockwise)	5 Hz/s
490	Operation Mode (of speed sensor 1)	4 – Quadruple Evaluation
491	Division marks (of speed sensor 1)	Division marks of the master speed sensor
550	Operation Mode	3 – Repetition Frequency
555	Repetition Freq. Operation	3 – Freq. Speed Sensor 1
556	Division Marks (of Multifunctional output 1)	1024
760	Operation Mode (of speed sensor monitoring)	2 – Error
766	Actual speed source	1 – Speed sensor 1
Slave Settings		
30	Configuration	215 – speed-controlled field-oriented control with electronic gear
420	Acceleration (Clockwise)	10 Hz/s
421	Deceleration (Clockwise)	10 Hz/s
490	Operation Mode (of speed sensor 1)	4 – Quadruple Evaluation
491	Division marks (of speed sensor 1)	Division marks of the slave speed sensor
496	Operation Mode (of repetition frequency input)	62 – S6IND Double Evaluation pos.
497	Divider (of repetition frequency input)	1024
685	Gear Factor Numerator	1
686	Gear Factor Denominator	1
689	Operation Mode (of electronic gear)	1 – Fixed
760	Operation Mode	2 – Error
766	Actual speed source	1 – Speed sensor 1

Note: The repetition frequency input receives the reference frequency value in single-channel mode. The reference frequency value is transmitted, but not the direction of rotation. In this case the direction of rotation must be set via the control terminals S2IND and S3IND at the slave.

Example 2: Transmission of the reference frequency value with information about direction of rotation, frequency inverter with expansion modules

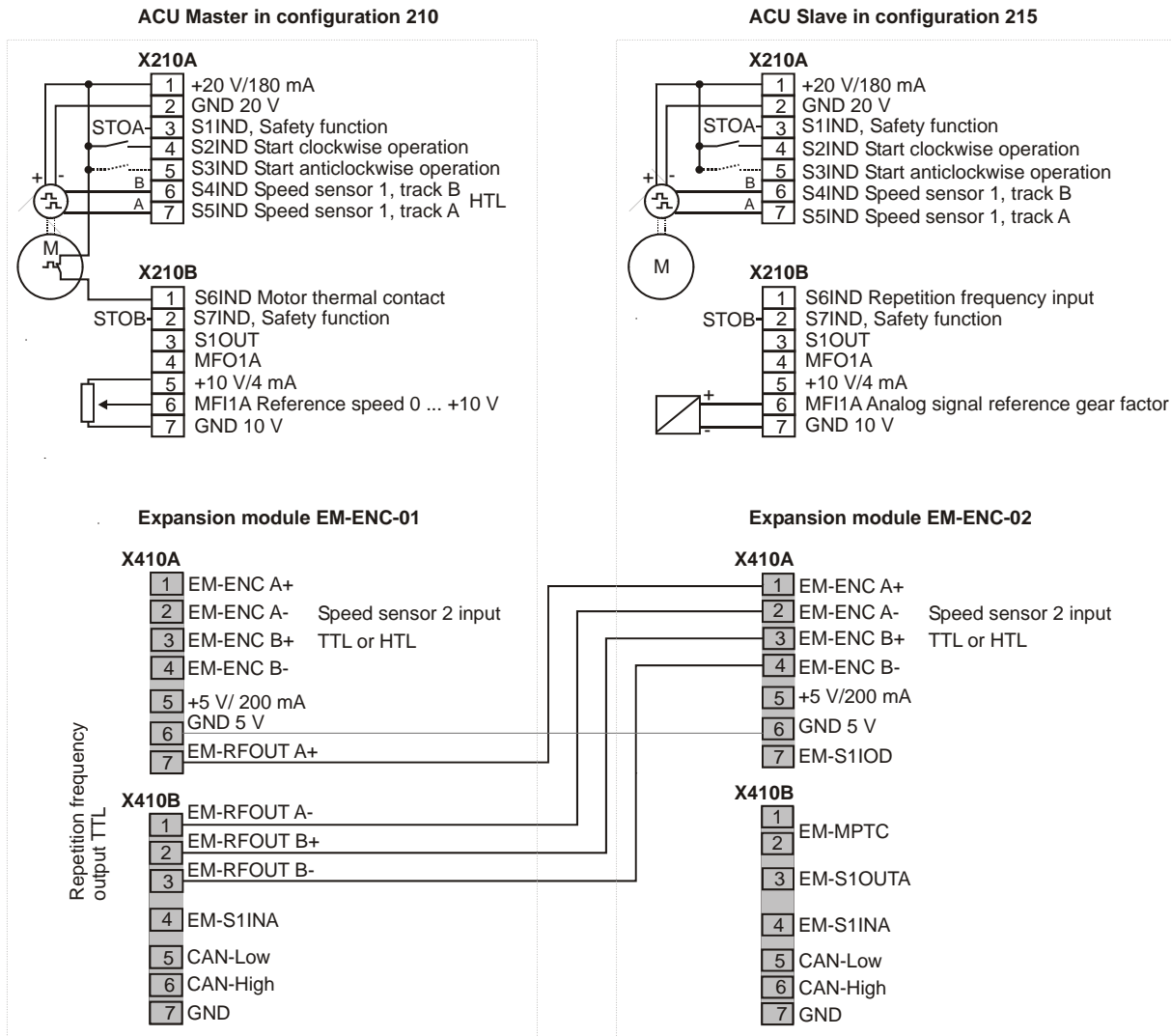



The digital inputs of the frequency inverter or the speed sensor inputs EM-ENC (extended speed sensor evaluation) can be used alternatively as speed sensor inputs.

Speed sensor input of frequency inverter basic unit:
HTL, 12 to 30 VDC

Speed sensor input EM-ENC of the expansion module:
TTL according to RS-422A/RS-485 or
HTL, 5 to 30 VDC

Overview of Parameter Setting Examples:

Parameter		Setting/Selection
Master Settings		
30	Configuration	210 – speed-controlled field oriented control
420	Acceleration (Clockwise)	5 Hz/s
421	Deceleration (Clockwise)	5 Hz/s
490	Operation Mode (of speed sensor 1)	4 – Quadruple Evaluation
491	Division marks (of speed sensor 1)	Division marks of the master speed sensor
546	Operation Mode Repetition Frequency	101 – Frequency speed sensor 1 wo. corr.
760	Operation Mode (of speed sensor monitoring)	2 – Error
766	Actual speed source	1 – Speed sensor 1
Slave Settings		
30	Configuration	215 – speed-controlled field-oriented control with electronic gear
 125	El. Gear Reference Frequency	81 – Freq. Speed Sensor 2
 147	Position Reference Value	83 – Position Speed Sensor 2
 148	Position Actual Value	82 – Position Speed Sensor 1
420	Acceleration (Clockwise)	10 Hz/s
421	Deceleration (Clockwise)	10 Hz/s
490	Operation Mode (of speed sensor 1)	4 – Quadruple Evaluation
491	Division marks (of speed sensor 1)	Division marks of the slave speed sensor
493	Operation Mode (of speed sensor 2)	4 – Quadruple Evaluation
494	Division marks (of speed sensor 2)	Division marks of the master speed sensor
495	Operation Mode Level (of speed sensor 2)	0 – push-pull
685	Gear Factor Numerator	1
686	Gear Factor Denominator	1
689	Operation Mode (of electronic gear)	11 – Fixed with position controller
696	Amplification Position Controller	10.00%
697	Lim. Position Deviation	99 999°
698	Lim. Position Controller	3.00 Hz
766	Actual speed source	1 – Speed sensor 1

 This parameter is available after loading of a configuration file, e.g. swc215.xpi.

5 Electronic gear via System bus

5.1 Speed Sensor Simulation

If the electronic gear is realized by means of the System Bus, the transmitted position data must be converted in a pulse-width modulated repetition frequency signal. This is done via the speed sensor simulation (remote encoder) which works as an internal speed sensor. The type of evaluation is adjusted via parameter *Operation Mode 498*.

Operation mode	Function
0 - Off	Speed measurement not active
1 - Single Evaluation	Two-channel speed sensor with recognition of direction of rotation via track signals A and B. One signal edge is evaluated per division mark.
2 - Double Evaluation	Two-channel speed sensor with recognition of direction of rotation via track signals A and B. Two signal edges are evaluated per division mark.
4 - Quadruple Evaluation	Two-channel speed sensor with recognition of direction of rotation via track signals A and B. Four signal edges are evaluated per division mark.

Via parameter *Division Marks 499*, the number of division marks per revolution for generation of the signal for the speed sensor simulation is defined.

Parameter		Settings		
No.	Description	Min.	Max.	Fact. sett.
499	Division Marks	1	8192	1024

Note: For the speed sensor simulation (remote encoder), the settings for *Operation Mode 490* and *Division Marks 491* of the Master frequency inverter must be taken over.

5.2 Adjustment Options

The repetition frequency is transmitted via the System Bus.

Note: Only the parameterization required for realizing the electronic gear are described here. For operation of the System Bus, further settings are required. These are described in the operating instructions of the expansion modules with System Bus.

5.2.1 Frequency Inverter as Master

If a frequency inverter is configured as Master of the electronic gear, the following settings can be made for the transmission of the repetition frequency via the System Bus.

- If not yet done after commissioning, select a configuration for parameter *Configuration 30*, e.g. Configuration "210 – speed-controlled field-oriented control" for speed control of the Master drive with speed sensor feedback. Depending on the application, another configuration can be selected, too.
- If a configuration with speed sensor feedback is selected, check if the speed sensor monitoring is switched on. Speed sensor monitoring is activated by default. By selecting operation mode "2 – Error" for parameter *Operation Mode 760*, you can switch on the speed sensor monitoring.
- Select a source for a Transmit-PDO of data type long, e.g. select signal source "80 - Speed Sensor 1" via parameter *TxPDO1 Long1 954* for transmission of the repetition frequency to the Slave.

Note: The parameters of the System Bus (e.g. TxPDO's for transmission of the data) are only available if the file sysbus.xpi is loaded in the software VPlus.

5.2.2 Slave Settings

For the function of the electronic gear via System Bus, the following settings (examples) can be made.

- If not done yet after the commissioning, select one of the configurations with electronic gear for parameter *Configuration* **30**, e.g. Configuration "215 – speed-controlled field-oriented control with electronic gear". Depending on the application, another configuration with electronic gear can be selected, too.
- If a configuration with speed sensor feedback is selected, check if the speed sensor monitoring is switched on. Speed sensor monitoring is activated by default. By selecting operation mode "2 – Error" for parameter *Operation Mode* **760**, you can switch on the speed sensor monitoring.
- Set parameters *Acceleration (Clockwise)* **420** and *Deceleration (Clockwise)* **421** or *Acceleration Anticlockwise* **422** and *Deceleration Anticlockwise* **423** to the required values. For synchronous acceleration and deceleration of the drives, set the values of the Slave slightly higher than the values of the Master. These increased values are to ensure that the Slave drive can follow the Master drive in dynamic operation cases.
- Assign a RxPDO source for the repetition frequency received to parameter *El. Gear Reference Frequency* **125**, e.g. source "708 – RxPDO1 Long1".

Note: The parameter *El. Gear Reference Frequency* **125** is only available if the file for a configuration with electronic gear is loaded in the software VPlus, e.g. swc215.xpi.

- Select an *Operation Mode* **689** and adjust the required transmission ratio via parameters *Gear Factor Numerator* **685** and *Gear Factor Denominator* **686**.

Overview of Parameter Setting Examples:

Parameter		Setting/Selection
Master Settings		
30	Configuration	210 – speed-controlled field oriented control
420	Acceleration (Clockwise)	5 Hz/s
421	Deceleration (Clockwise)	5 Hz/s
954	TxPDO1 Long1	80 – Speed Sensor 1
Slave Settings		
30	Configuration	215 – speed-controlled field-oriented control with electronic gear
125	El. Gear Reference Frequency	708 – RxPDO1 Long1
420	Acceleration Clockwise	10 Hz/s
421	Deceleration Clockwise	10 Hz/s
498	Operation Mode	4 – Quadruple Evaluation
499	Division marks	1024
689	Operation Mode	1 – Fixed
685	Gear Factor Numerator	1
686	Gear Factor Denominator	1
760	Operation Mode	2 – Error

5.3 Position Control via System Bus

Example of Position Control Settings via System Bus:

Master:

- Select a source for a Transmit-PDO of data type long, e.g. select signal source "80 – Speed Sensor 1 via parameter *TxPDO1 Long1* **954** for transmission of the repetition frequency to the Slave.
- Select a source for a Transmit-PDO of data type Word, e.g. via parameter *TxPDO2 Word1* **960**, select the signal source "82 - Position Speed Sensor 1" or "289 - Position Rep. Frequency Input" for transmission of the position to the Slave.



Note: The parameters of the TxPDO's for transmission of the data is only available if the file sysbus.xpi is loaded in the software VPlus. Parameters 125, 147 and 149 which are described in the following are contained in the configuration files to be loaded, e.g. swc215.xpi.

Slave:

- Select operation mode "11 – fixed with position control" for parameter *Operation Mode* **689**.
- Assign a RxPDO source for the repetition frequency received to parameter *El. Gear Reference Frequency* **125**, e.g. source "708 – RxPDO1 Long1".
- Assign a RxPDO source for the position value received to parameter *Position Reference Value* **147**, e.g. source "714 – RxPDO2 Word2". The position value received is thus specified as the reference value for the Slave.
- Select a signal source (signal at digital input or internal logic signal) for parameter *Start Position Controller* **149** or select "6 – On" if the position controller is to be switched on permanently.
- Select an operation mode for the speed sensor simulation for parameter *Operation Mode* **498**. Via this function, the function of an incremental speed sensor is simulated.
- Via parameter *Division Marks* **499**, you can adjust the output frequency of the speed sensor simulation.
- Adjust parameters 696 to 699 of the position controller.

6 Parameter List

























The parameter list is structured according to the menu branches of the control unit. For better clarity, the parameters have been marked with pictograms:

-  The parameter is available in the four data sets.
-  This parameter cannot be written in the operation of the frequency inverter.
-  This parameter is available after loading of a configuration file, e.g. swc215.xpi.

6.1 Actual Value Menu (VAL)

Actual Values of the Frequency Inverter				
No.	Description	Unit	Display range	Chapter
217	Freq. Speed Sensor 1	Hz	0.00 ... 999.99	4.8
219	Freq. Speed Sensor 2	Hz	0.00 ... 999.99	4.8
252	Repetition Frequency Input	Hz	0.00 ... 999.99	4.8
283	Reference Ramp Frequency	Hz	0.00 ... 999.99	4.8

6.2 Parameter Menu (PARA)

Digital Inputs						
No.	Description	Unit	Setting range	Chapter		
	96	Index Controller Release	-	Selection	4.7	
Electronic Gear						
	125	El. Gear Reference Frequency	-	Selection	4.5	
Digital Inputs						
	132	Offset Switch 1	-	Selection	4.4	
	133	Offset Switch 2	-	Selection	4.4	
Position Controller						
	147	Position Reference Value	-	Selection	4.6	
	148	Position Actual Value	-	Selection	4.6	
Digital Inputs						
	149	Start Position Controller	-	Selection	4.6	
Fixed Frequencies						
	485	Fixed Frequency 5	Hz	-999.99 ... 999.99	4.4	
	486	Fixed Frequency 6	Hz	-999.99 ... 999.99	4.4	
Speed Sensor Simulation						
		498	Operation mode	-	Selection	5.1
		499	Division marks	-	1 ... 8192	5.1
Index controller						
	591	Amplification	-	0.0 ... 100.0	4.7	
	592	Integral Time	ms	0.0 ... 60 000	4.7	
	593	Limit	%	0.00 ... 200.00	4.7	
	594	Master Index Divider	-	1 ... 65 535	4.7	
	595	Slave Index Divider	-	1 ... 65 535	4.7	
	596	Offset	%	-50.00 ... 50.00	4.7	
	597	Warning Level	%	0.00 ... 50.00	4.7	
	598	Operation Mode	-	Selection	4.7	
Electronic Gear						
	685	Gear Factor Numerator	-	-300.00 ... 300.00	4.3.1	
	686	Gear Factor Denominator	-	0.01 ... 300.00	4.3.1	
	687	Analog Factor Max.	-	0.00 ... 3.00	4.3.2	
	688	Analog Factor Min.	-	0.00 ... 3.00	4.3.2	
	689	Operation Mode	-	Selection	4.2	
Position Controller						
	696	Amplification Position Controller	%	0.00 ... 200.00	4.6	
	697	Lim. Position Deviation	°	0 ... 99 999	4.6	
	698	Lim. Position Controller	Hz	0.00 ... 1000.00	4.6	
	699	Position Adjustment	°	-3200.0 ... 3200.0	4.6	

AUSTRALIA

BONFIGLIOLI TRANSMISSION (Aust) Pty Ltd., Cox Place Glendenning
NSW 2761 (Australia) Locked Bag 1000 Plumpton NSW 2761
Tel. (+61) 2 8811 8000 - Fax (+61) 2 9675 6605
www.bonfiglioli.com.au - sales@bonfiglioli.com.au

AUSTRIA **BEST**

MOLL MOTOR GmbH
Industriestrasse 8 - 2000 Stockerau
Tel. (+43) 2266 63421+D/W - Fax (+43) 6342 180
www.mollmotor.at - office@mollmotor.at

BELGIUM **BEST**

ESCO TRANSMISSION N.V./S.A.
Culliganlaan 3 - 1831 Machelem Diegem
Tel. (+32) 2 7176460 - Fax (+32) 2 7176461
www.esco-transmissions.be - info@esco-transmissions.be

BRASIL

BONFIGLIOLI REDUTORES DO BRASIL INDUSTRIA E COMERCIO LTDA
Av. Padre Anchieta 365 - 09891-420 - Sao Bernardo do Campo
Sao Paulo (Brasil) Tel. (+55) 11 4337 1806 - Fax (+55) 11 4337 5083
www.bonfigliolidobrasil.com.br - bonfiglioli@bonfigliolidobrasil.com.br

CANADA

BONFIGLIOLI CANADA INC.
2-7941 Jane Street - Concord, Ontario L4K 4L6
Tel. (+1) 905 7384466 - Fax (+1) 905 7388933
www.bonfigliolicanada.com - sales@bonfigliolicanada.com

CHILE **BEST**

IMATESA S.A.
Santa Rosa 5699 - San Miguel - Santiago
Tel. (+56) 2 5264702 - Fax (+56) 2 5265878
www.imatesa.cl - imatesa@imatesa.cl

CHINA

BONFIGLIOLI DRIVES (SHANGHAI) CO. LTD.
19D, No. 360 Pudong Road (S) - New Shanghai International Tower
200120 Shanghai (P.R. China)
Tel. (+86) 21 69225500 - Fax (+86) 21 69225511
www.bonfiglioli.cn - bds@bonfiglioli.com.cn

FRANCE

BONFIGLIOLI TRANSMISSIONS S.A.
14 Rue Eugène Pottier BP 19 - Zone Indust. de Moimont II - 95670 Marly la Ville
Tel. (+33) 1 34474510 - Fax (+33) 1 34688800
www.bonfiglioli.fr - btf@bonfiglioli.fr

GERMANY

BONFIGLIOLI DEUTSCHLAND GmbH
Sperberweg 12 - 41468 Neuss
Tel. (+49) 02131 2988-0 - Fax (+49) 02131 2988-100
www.bonfiglioli.de - info@bonfiglioli.de

GREAT BRITAIN

BONFIGLIOLI UK Ltd
Industrial Equipment - Unit 3 Colemeadow Road
North Moons Moat - Redditch, Worcestershire B98 9PB
Tel. (+44) 1527 65022 - Fax (+44) 1527 61995
www.bonfiglioli.com - uksales@bonfiglioli-uk.com

Mobile Equipment
5 Grosvenor Grange, Woolston, Warrington - Cheshire WA1 4SF
Tel. (+44) 1925 852667 - Fax (+44) 1925 852668
www.bonfiglioli-uk.com - salesmobile@bonfiglioli-uk.com

GREECE **BEST**

B.E.S.T. HELLAS S.A.
O.T. 48A T.O. 230 - C.P. 570 22, Industrial Area - Thessaloniki
Tel. (+30) 2310 796456 - Fax (+30) 2310 795903
www.bonfiglioli.gr - info@bonfiglioli.gr

HOLLAND **BEST**

ELSTO AANDRIJFTECHNIEK
Loosterweg, 7 - 2215 TL Voorhout
Tel. (+31) 252 219 123 - Fax (+31) 252 231 660
www.elsto.nl - info@elsto.nl

HUNGARY **BEST**

AGISYS AGITATORS & TRANSMISSIONS LTD
2045 Törökbálint, Tó u.2. (Hungary)
Tel. (+36) 23 50 11 50 - Fax (+36) 23 50 11 59
www.agisys.hu - info@agisys.hu

INDIA

BONFIGLIOLI TRANSMISSIONS PVT Ltd.
PLOT AC7-AC11 Sidco Industrial Estate - Thirumudivakkam - Chennai 600 044
Tel. +91(0) 44 24781035 / 24781036 / 24781037
Fax +91(0) 44 24780091 / 24781904
www.bonfiglioli.co.in - bonfig@vsnl.com

INDONESIA **BEST**

PT. ANEKAMAKMUR TEKNIK NUSAJAYA
Pertokoan Glodok Makmur No. 32 - Jakarta Barat
Tel. (+62) 21 624 8828 - Fax (+62) 21 624 2405
www.anekamakmur.com - sales@anekamakmur.com

ITALY

BONFIGLIOLI ITALIA S.p.A.
Via Sandro Pertini lotto 7b - 20080 Carpiano (Milano)
Tel. (+39) 02 985081 - Fax (+39) 02 985085817
www.bonfiglioli.it - customerservice.italia@bonfiglioli.it

A.T.I. di Morganti E. C. sas **BEST**
Via Pistoiese 219 - 50047 Prato - Tel. 0574 6961 - Fax 0574 790996
www.atimorganti.it - ati.morganti@texnet.it

BONETTI LUIGI srl **BEST**
Strada Padana Superiore verso VR n.7 - 36100 Vicenza
Tel. 0444 563120 - Fax 0444 961979
www.bonettimotoriduttori.com - bonetti.luigi@libero.it

CASA DEL CUSCINETTO sas di Castignoli e C. **BEST**

Strada Val Nure 18/a - 29100 Piacenza
Tel. 0523 755518 - 0523 756315 - Fax 0523 457804
www.casadelcuscinetto.net - antonio@casadelcuscinetto.net

CENTO TRASMISSIONI srl **BEST**

Via Friuli 23 - 40060 Osteria Grande (BO)
Tel. 051 6958222 - Fax 051 6958253
www.centotrasmissioni.com - cento@centotrasmissioni.com

COMEG sas **BEST**

Via E. Fermi 12/16 - 10148 Torino - Tel. 011 2745582 - Fax 011 2745190
www.comegmotori.it - salesto2@comegmotori.it

CONTASTA COMPONENTI srl **BEST**

di Franca Di Clemente e Figli
Via Po 65/67 - Zona Comm. 66020 S. Giovanni Teatino (CH)
Tel. 085 4462696 - Fax 085 4461754
www.gruppofit.it - grupprofitt@grupprofitt.it

D.L. di Danielli B e Loli G. srl **BEST**

Via Fucini 2 - 40132 Bologna - Tel. 051 6177611 - Fax 051 6177630
www.daniellielloli.it - info@daniellielloli.it

EGA TECNIC srl **BEST**

Via Macconi 171/2 - 38100 Trento
Tel. 0461 822176 - Fax 0461 821643 - www.egatecnic.it - info@egatecnic.it

FIMU srl **BEST**

Via Artigianato - 25128 Savignano (CN)
Tel. 0172 713542 - Fax 0172 715489 - www.fimusrl.com - fimu@fimusrl.com

FIPTÉ GROUP srl **BEST**

Via Gambalera 210 - 15047 Spinetta Marengo (AL)
Tel. 0131 618058 - Fax 0131 213907
www.fipte-group.com - info@fipte-group.com

FITMA srl **BEST**

Viale del Commercio 10 - 37042 Caldiero (VR)
Tel. 045 6132511 - Fax 045 6150270 - www.fitma.it - fitma@fitma.it

F.M.I. FRANCESCHI srl **BEST**

Strada Baganzola 28/a - 43100 Parma
Tel. 0521 992200 - Fax 0521 987303 - www.fmparma.it - fmi@fmparma.it

FORN. IND. DELLACASA **BEST**

Via Sampierdarena 231/r - 16149 Genova
Tel. 010 6459954 - Fax 010 417916 - www.dellacasa.it - info@dellacasa.it

INDUSTRIAL FURNITURE MORO snc **BEST**

Via dei Da Prata 34 - 31100 Treviso - Tel. 0422 428835 - Fax 0422 428830
www.morotreviso.com - info@morotreviso.com

MG COMPONENTS sas di Gaetti Marcello e C. **BEST**

Via Giglioli Valle 33 - 42100 Reggio Emilia
Tel. 0522 518783 - Fax 0522 516541
www.mgcomponents.it - mgcomponents@virgilio.it

MICAR snc di Sandro Arminio e C. **BEST**

Via Rosso di S. Secondo, 15 - 20134 Milano
Tel. 02 70491091 - Fax 02 70126372 - www.micar.it - info@micar.it

MINETTI spa Filiale di Bergamo **BEST**

Via Canovine, 14 - 24100 Bergamo - Tel. 035 327111 - Fax 035 316767
www.minettigroup.com - minettibergamo@minettigroup.com

MINETTI spa Filiale di Brescia **BEST**

Via G. di Vittorio, 38 - Z.I. - 25128 Brescia
Tel. 030 3582734 - Fax 030 3582760
www.minettigroup.com - minettibrescia@minettigroup.com

S.I.R.I. srl **BEST**

Via Dell'Industria 9 - 04011 Aprilia (LT)
Tel. 06 9206291 - Fax 06 9258643 - www.sirisrl.com - info@sirisrl.com

SAROK ITALIA srl **BEST**

Via Valsugana, 4 - 22053 Lecco (CO) - Tel. 0341 357811 - Fax 0341 283096
www.sarok.it - sarokdue@sarok.it

SAROK DUE srl **BEST**

Via 1 Maggio 9/11 - 20028 S. Vittore Olona (MI)
Tel. 0331 423911 - Fax 0331 423942 - www.sarok.it - sarokdue@sarok.it

SOTEK srl **BEST**

Via F. Rossi 23 - 60044 Fabriano (AN)
Tel. 0732 250823 - Fax 0732 22919 - www.sotek.it - info@sotek.it

T.I.M. Tec.Ind. Modenesi **BEST**

Via Franz Leahr 25 - 41100 Modena - Tel. 059 282500 - Fax 059 282404
www.timmodena.com - timmodena@timmodena.com

TECHNOBI srl **BEST**

Via Lazio, 65 - 20090 Buccinasco (MI)
Tel. 02 45712362 - Fax 02 45712219 - www.technobi.it - vendite@technobi.it

TECNICA INDUSTRIALE srl **BEST**

S.P. 231 km I ex S.S. 98 Km 80, 176 - 70026 Modugno (BA)
Tel. 080 5367089 - 080 5367090 - Fax 080 5367091
www.tecnicaindustriale.it - info@tecnicaindustriale.it

TECNOFORNITURE srl **BEST**

Via Pasubio 106 - 63037 Porto d'Ascoli (AP)
Tel. 0735 761171 - Fax 0735 655266
www.tecnoforniture.it - info@tecnoforniture.it

TRA - MEC snc **BEST**

Via Delle Industrie s.n. - 21020 Casale Litta (VA)
Tel. 0332 945860 - Fax 0332 967864 - www.tra-mec.it - info@tra-mec.it

UMBRIA TRASMISSIONI srl **BEST**

Via delle Robinie 23 Z.I. - 06083 Bastia Umbra (PG)
Tel. 075 8010585 - Fax 075 8002191
www.umbriatrasmissioni.it - info@umbriatrasmissioni.it

V.B. Moto Trasmissioni snc **BEST**

di Volpe E. E. Bianchi P. E. C. - Via Enzo Ferrari 335 - 47037 Cesena (FC)
Tel. 0547 630610 - Fax 0547 630615
www.vbmototrasmissioni.it - info@vbmototrasmissioni.it

VENETA BEARINGS srl **BEST**

Via Torino 15 - 35035 Mestrino (PD)
Tel. 049 9001944 - 049 9001549 - Fax 049 9001543
www.venetabearings.it - info@venetabearings.it

NEW ZEALAND **BEST**

SAECO BEARINGS TRANSMISSION
36 Hastie Avenue, Mangere Po Box 22256, Otahuhu - Auckland
Tel. (+64) 9 634 7540 - Fax (+64) 9 634 7552 - mark@saeco.co.nz

POLAND **BEST**

POLPACK Sp. z o.o. - Ul. Chrobrego 135/137 - 87100 Torun
Tel. (+48) 56 659235 - 659236 - Fax (+48) 56 659238
www.polpack.com.pl - polpack@polpack.com.pl

PORTUGAL **BEST**

BT BONFITTEC Equipamentos Industriais, Lda.
Largo do Colegio de Ermesinde, 70 - Formiga 4445-382 Ermesinde
Tel. (+351) 229759634/5/6 - Fax (+351) 229752211
www.bonfittec.pt - bonfittec@bonfittec.pt

RUSSIA **BEST**

FAM
57, Maly prospekt, V.O. - 199048, St. Petersburg
Tel. (+7) 812 3319333 - Fax (+7) 812 3271454
www.fam-drive.ru - info@fam-drive.ru

SPAIN

TECNOTRANS BONFIGLIOLI S.A.
Pol. Ind. Zona Franca sector C, calle F, n°6 08040 Barcelona
Tel. (+34) 93 4478400 - Fax (+34) 93 3360402
www.tecnotrans.com - tecnotrans@tecnotrans.com

SOUTH AFRICA

BONFIGLIOLI POWER TRANSMISSION Pty Ltd.
55 Galaxy Avenue, Linbro Business Park - Sandton
Tel. (+27) 11 608 2030 OR - Fax (+27) 11 608 2631
www.bonfiglioli.co.za - bonfigsales@bonfiglioli.co.za

SOUTH KOREA **BEST**

YOUN HO INDUSTRIAL
Room B1, World Plaza Bldg. - 1262 Guro-Dong, Gurd-Gu, Seoul
Tel. (+82) 2 626 43201 - Fax (+82) 2 263 23202
www.younho.com - younho@younho.com

SWEDEN

BONFIGLIOLI SKANDINAVIEN AB
Koppargatan 8 - 234 35 Lomma (Sweden)
Tel. (+46) 40418230 - Fax (+46) 40414508
www.bonfiglioli.se - info@bonfiglioli.se

THAILAND **BEST**

K.P.T. MACHINERY (1993) CO.LTD.
259/83 Soi Phibonvies, Sukhumvit 71 Rd. Phrakhanong-nur
Wattana, Bangkok 10110 - Tel. (+66) 2 3913030/7111998
Fax (+66) 2 7112852/3811308/3814905
www.kpt-group.com - sales@kpt-group.com

TURKEY

BONFIGLIOLI TURKIYE
Atatürk Organize Sanayi Bölgesi, 10015 Sk. No: 17, Çiğli - Izmir
Tel. (+90) 02 322 328 22 77 (pbx) - Fax (+90) 02 322 328 04 14
www.bonfiglioli.com.tr - info@bonfiglioli.com.tr

USA

BONFIGLIOLI USA, INC.
3541 Hargrave Drive Hebron, Kentucky 41048
Tel. (+1) 859 334 3333 - Fax (+1) 859 334 8888
www.bonfiglioliusa.com
industrialsales@bonfiglioliusa.com - mobilesales@bonfiglioliusa.com

VENEZUELA **BEST**

MAICA SOLUCIONES TECNICAS C.A.
Calle 3B - Edif. Comindu - Planta Baja - Local B
La Urbina - Caracas 1070
Tel. (+58) 212 2413570 / 2425268 / 2418263
Fax (+58) 212 2424552 - Tlx 24780 Maica V - maica1@cantv.net

HEADQUARTERS

BONFIGLIOLI RIDUTTORI S.p.A.
Via Giovanni XXIII, 7/A
40012 Lippo di Calderara di Reno
Bologna (Italy)
Tel. (+39) 051 6473111 - Fax (+39) 051 6473126
www.bonfiglioli.com - bonfiglioli@bonfiglioli.com

SPARE PARTS BONFIGLIOLI

B.R.T.
Via Castagnini, 2-4 - Z.I. Bargellino
40012 Calderara di Reno - Bologna (Italy)
Tel. (+39) 051 727844 - Fax (+39) 051 727066
www.brtonfiglioliricambi.it - brt@bonfiglioli.com

ACTIVE Cube



www.bonfiglioli.com

 **BONFIGLIOLI**