



BlueRoll

THE BONFIGLIOLI PLATFORM FOR
MOBILE ROBOTS AND LOGISTIC SYSTEMS





We engineer dreams



Contents

BLUEROLL	4
The highest level of precision, efficiency and energy optimization	4
Fully committed to the efficiency of customers' system over its life cycle	5
THE BLUEROLL PLATFORM	6
MODULAR AND CUSTOMER-SPECIFIC AGV SOLUTIONS	7
BLUEROLL BASIC	8
BLUEROLL ADVANCED	10
BLUEROLL COMPACT: THE TOP-LEVEL INTEGRATION	12
OTHER BONFIGLIOLI SOLUTIONS FOR AGVS	13
TECHNICAL DATA	14
GLOBAL PRESENCE.....	18

BlueRoll

THE HIGHEST LEVEL OF PRECISION, EFFICIENCY AND ENERGY OPTIMIZATION

With more than 20 years of experience in creating tailored and forward-thinking motion control systems, Bonfiglioli has proven being a reliable partner as **one-stop shop for mechatronic applications** in industrial automation.

Bonfiglioli engineering specialists work side by side with customers to develop dedicated integrated solutions, covering the entire motion drive train according to an **Industry 4.0 approach**.

Thanks to the extensive know-how and the long-term collaboration with key customers, our two centers of excellence, located in Italy and Germany, develop **breakthrough mechatronic innovations**, including low backlash planetary gearboxes, servomotors, open and closed loop inverters, servo drives and energy regenerative units.

This, combined with a comprehensive range of **Professional Services**, enables us to respond to customers' requests by:

- providing **user friendly, plug & play solutions**
- **increasing** applications' **efficiency** and **productivity**
- designing **flexible, modular solutions** targeted to a wide range of applications
- granting access to real time data for **diagnostic, maintenance** and **predictive analytics**



**ASSESSMENT &
RECOMMENDATION**



**ENGINEERING &
PLANNING**



**INSTALLATION &
COMMISSIONING**



**RETROFIT &
UPGRADE**



**MAINTENANCE &
REPAIR**

FULLY COMMITTED TO THE SUCCESS OF OUR CUSTOMERS' SYSTEM OVER ITS LIFE CYCLE

Bonfiglioli technical sales experts support customers with a proactive, flexible and dedicated approach **throughout the system's entire life cycle**.

- **Assessment and recommendation:** our team provides support starting from the very early stage of the project by assessing the requirements and developing a targeted analysis of the application, guiding customers in the choice of the most suitable components for their drive solution.
- **Engineering and planning:** our experts work with customers to co-engineer their application, offering consultancy in sizing, fine tuning and selecting the optimized drive train, always considering life cycle cost optimization.
- **Installation and commissioning:** we partner with our customers to ensure a quick, cost-effective and successful installation, optimizing the benefits and functions of their drive technology.
- **Retrofit and upgrade:** we update customers' machines with state-of-the-art technology to ensure constant levels of productivity, reliability and performance.
- **Maintenance and repair:** we work side by side with customers to avoid failures, reduce down times and ensure the best system operation.

The BlueRoll platform

MODULAR AGVS AND AMRS SOLUTIONS TAILORED TO YOUR NEEDS

BlueRoll is the Bonfiglioli platform specifically developed to respond to the demanding requirements of the AGVs and AMRs sector in terms of power density, position accuracy and high load capacity. With its **flexibility** and **full customization**, it offers a **modular solution**, that reduces complexity while ensuring **maximum power density** and **energy efficiency**.

FULL CUSTOMIZATION FOR RELIABLE PERFORMANCE AND HIGH POWER DENSITY



EXPERTISE FOR CUSTOMIZED SOLUTIONS

Active partnerships and **co-engineering** to satisfy a **wide range of individual requirements**, from design constraints to type of duty cycles



COMPLEXITY REDUCTION

The **freely configurable modular solution** is available in various combinations and sizes to match both **design and performance requirements**



SECTOR SPECIFIC REQUIREMENTS

The solution can be designed to **meet specific industry sector requirements** such as high / low ambient temperature, surface protection, higher IP protection, compliance with specific regulations

THE HIGHLY FLEXIBLE AND MODULAR PLATFORM FOR A WIDE SPECTRUM OF APPLICATIONS



WAREHOUSE & LOGISTICS



MATERIAL HANDLING



PHARMACEUTICAL



FOOD & BEVERAGE



E-COMMERCE

A dedicated solution for different vehicles design

In order to satisfy the requirements of a wide range of different vehicle concepts and designs, Bonfiglioli offers a **modular approach** for AGVs and AMRs, allowing the selection of the **best configuration** to effectively suit the specific application's needs.

Based on the design of your vehicle, we can provide the **single component** (servomotor or precision planetary gearbox, with and without the wheel) **or the integrated geared motor solution**, together with a wide range of **sector-specific components and options**, tuned to the requirements of mobile robots and logistic systems.

CUSTOMIZED LEVELS OF INTEGRATION

BLUEROLL COMPACT

Extra compact
Servo geared motors

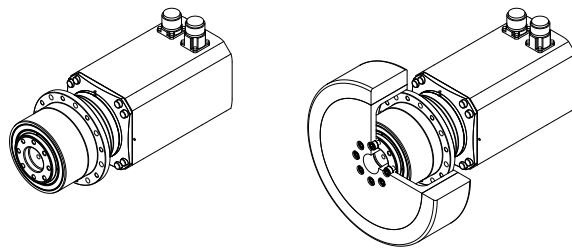

BLUEROLL ADVANCED

Servo geared motors

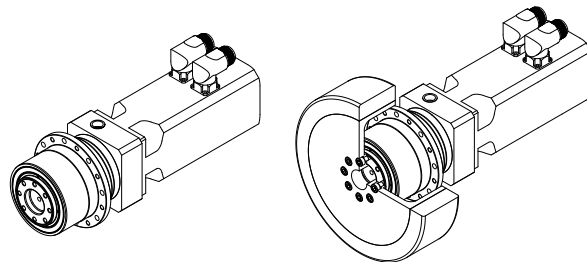

BLUEROLL BASIC

Precision Planetary Gearboxes

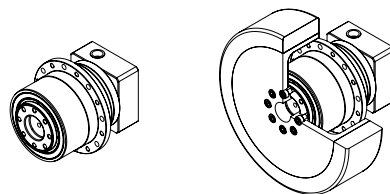

Each version of BlueRoll is available both with and without the wheel.

BlueRoll Basic

TQW: PRECISION PLANETARY GEARBOXES FOR AMRS AND AGVS

BlueRoll Basic, based on our TQW planetary gearbox, represents the ideal solution for your drive wheels.. Thanks to its **heavy load capability, exceptional compactness, efficiency** and **durability**, it fulfills application-specific requirements in an optimum way.

High energy efficiency

Compared to other technologies, planetary gearboxes allow to reduce energy consumption at any load condition, hence extending battery life.

Minimized installation space

Since the gearbox is almost completely enclosed by the wheel, the required installation space is reduced to the minimum

Easy installation

Thanks to its fixing flange design, the gearbox can be fitted directly to the chassis of the vehicle

Heavy loads capability

The integrated wheel is supported directly by the reinforced gearbox bearings, which permit ultra-high radial forces

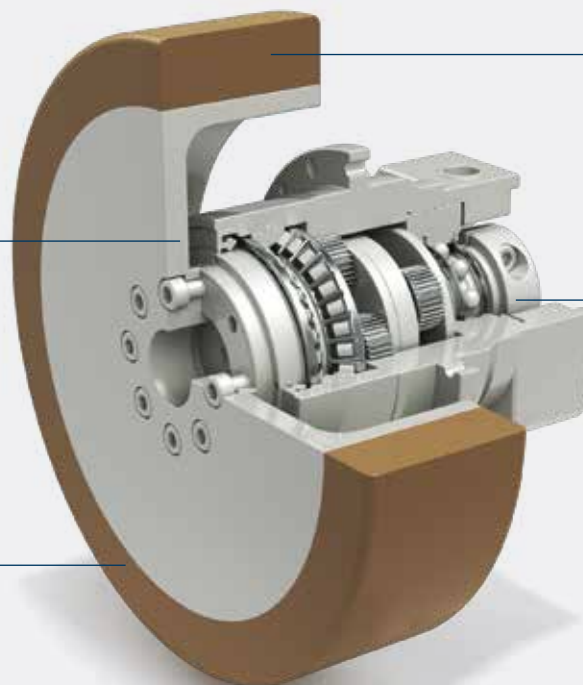

THE TQW PRECISION PLANETARY GEARBOX SERIES

TQW is available in **three sizes**, each supporting a maximum load (per wheel) of 360, 720, 1020kg. and coupled with a specific industrial wheel, with a diameter of 160 mm, 200 mm or 250 mm. **Maximum speeds** up to 2 m/s (7.2 km/h) are possible.

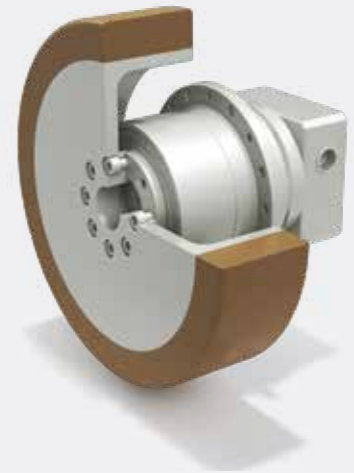

GEAR RATIOS

- 9 ... 100

DEGREE OF PROTECTION

- IP65

BACKLASH

- Less than 10 arcmin

MAX RADIAL FORCE

- 2300 ... 5200 N

MAXIMUM INPUT SPEED

- 4000 ... 6000 rpm

MAXIMUM LOAD CAPACITY

- 360 ... 1020 kg

MAXIMUM SPEED

- <2m/s

POSITION PRECISION

- 0.2 ... 0.3 mm

WEIGHT (WHEEL INCLUDED)

- 4,2 ... 18,1 kg

KEY FEATURES

- Extremely compact
- High energy efficiency
- Output shaft supported by heavy load capacity bearings
- Highly reliable
- Life lubricated
- Designed for continuous and intermittence duty

NOMINAL TORQUE (Nm)

TQW 060	30
TQW 070	65
TQW 090	155

MAX LOAD CAPACITY (kg)

TQW 060	360
TQW 070	720
TQW 090	1,020

BlueRoll Advanced

A POWERFUL AND MODULAR SOLUTION TO DRIVE ANY AGVS AND AMRS DESIGN

Thanks to the effective combination of our **Permanent Magnet Servomotors**, characterized by high torque density and compact design, and our **Precision Planetary Gearboxes** designed for high loads support, BlueRoll Advanced offers the **ideal performance for AGV applications**, ensuring great levels of flexibility, safety and space-saving.

Embeds all the benefits of TQW gearbox from BlueRoll Basic

Tailored for your mobile robot thanks to a wide range of sector-specific features, i.e.: low voltage supply, special feedbacks including safety encoders, holding brakes

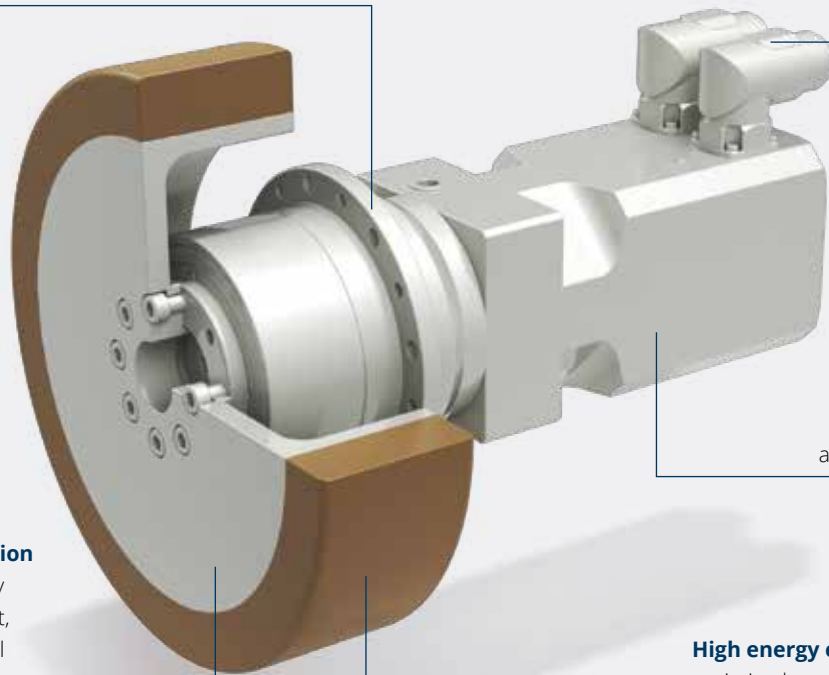

The **modular design** allows you to freely combine gearbox and motor to fulfill different application requirements

Extensive customization possibilities to meet any application requirement, including environmental constraints (e.g. low temperature)

High energy efficiency thanks to the optimized combination of servo motor and gearbox

PERMANENT MAGNET SERVO GEARMOTORS

The BlueRoll Advanced servomotors are permanent magnet synchronous gearmotors with **highly compact dimensions** and **low inertia**. They meet the most stringent demands for precision, dynamics and speed settings thanks to their high-quality neodymium iron boron rare-earth magnets and optimized mechatronic integration. The solution allows great freedom in the **product customization**, thanks to the **wide range of options**, for an **optimized and flexible servo package**.

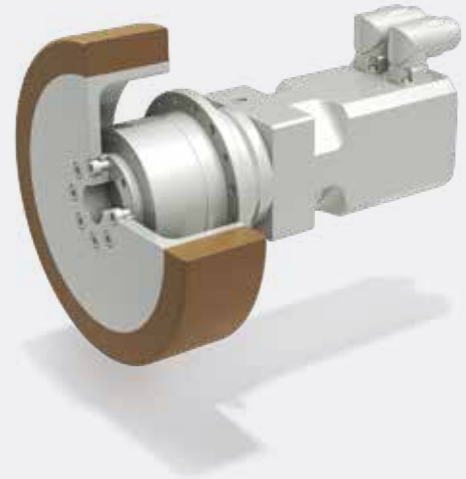

POWER SUPPLY

- Customized winding for low voltage supply (i.e. 48Vdc)

RATED SPEED

- 1600, 3000, 4500, 6000 rpm

SIZES

- 3 gearbox sizes
- 4 motor frames

BACKLASH

- Less than 10 arcmin

BRAKE

- Holding brake
- Safety brake

DEGREE OF PROTECTION

- IP 65, IP 67 possible

KEY FEATURES

- Highly customizable solution
- Specific matching between the individual application demands and the gearmotor's operating area
- Wide range of encoders and protocols suitable for functional safety
- Various connectors options or flying cable

BMD SERIES MOTOR TORQUE (Nm)

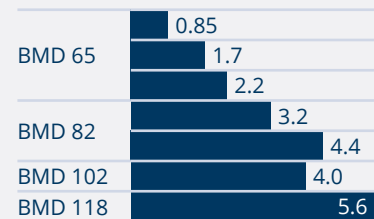

BlueRoll Compact: the top-level integration

EXTRA COMPACT SERVO GEARMOTORS

Reach the **highest level of customization and compactness** with our **complete solution**, characterized by **fully tested** and **validated dimensioning** tailored to your specific requirements. Developed to respond to customer's requests, the extreme compactness of this solution allows **greater flexibility in the design** of your AMR application.

Embeds all the benefits of TQW gearbox from BlueRoll Basic

Make the battery last longer: the combination of low voltage PMSM and a planetary gearbox in a compact design, makes BlueRoll the right choice for your battery-powered system.

Simplify your AGV design: the Compact version is **25% shorter** than the Advanced version, maximizing space-saving and preserving high-level performance.

Choose the best configuration: thanks to its wide range of gearbox ratios, feedback systems (including safety encoders), and motor options, BlueRoll is the most versatile platform on the market.

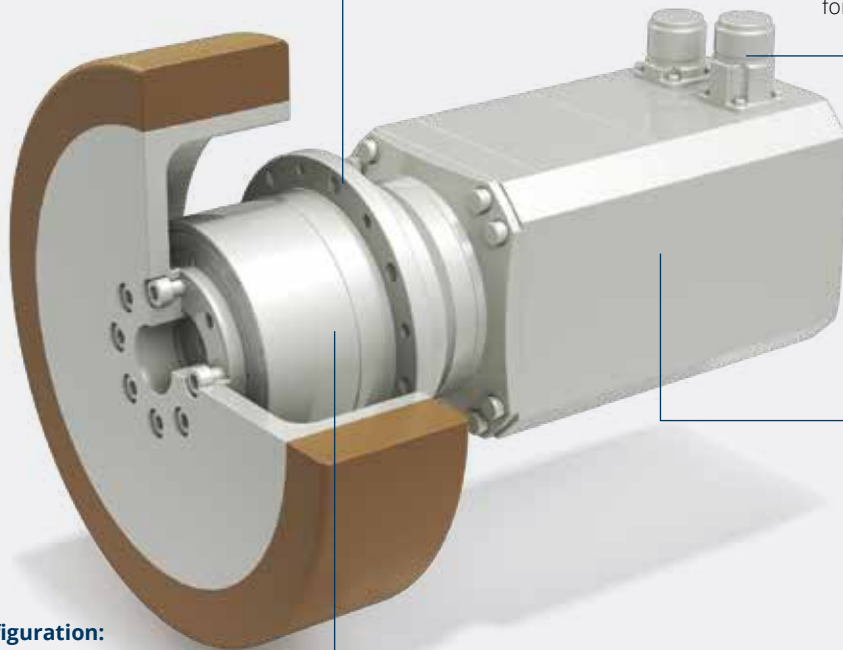

Other Bonfiglioli solutions for AGVs

Thanks to over 40 years of experience in the sector, Bonfiglioli is the right partner to support you in **developing and designing** electric powertrain and drive **solutions for warehouse vehicles**.

Our EL Series is able to respond to the most demanding requirements of warehousing applications, ensuring **great loads capability, extreme compactness** and **high maneuverability**.

EL SERIES

Bonfiglioli EL powertrains are a perfect match for the most demanding warehousing applications (Class 2 and Class 3). Warehousing trucks require high maneuverability in tight spaces, provided by drives like the EL series drives, with the smallest operating radius in vertical arrangements.



GEAR RATIOS

- 13 ... 32

POWER RANGE

- 2 ... 7 kW

MAIN OPTIONS

- Cold environment versions
- Integrated tiller or castor wheel supports

KEY FEATURES

- Two-stage helical & bevel gearboxes
- Manual steer and power steer versions
- Optimized gear design for efficiency and noise
- Integrated low-voltage electric motor
- Integrated parking brake
- Complete system with tyres

TORQUE (Nm)

EL100	450
EL09 V	500
EL96	500
EL10 V	900
EL300	1,100
EL92	1,500
EL93	1,500
EL94	1,500
EL14 V	1,900

MAX WHEEL LOAD (kg)

EL100	1,200
EL09 V	1,200
EL96	1,500
EL10 V	1,500
EL300	2,200
EL92	3,000
EL93	3,000
EL94	3,000
EL14 V	3,400



MATERIAL
HANDLING
VEHICLES



REACH
TRUCKS



TOW
TRACTORS



TQW 060

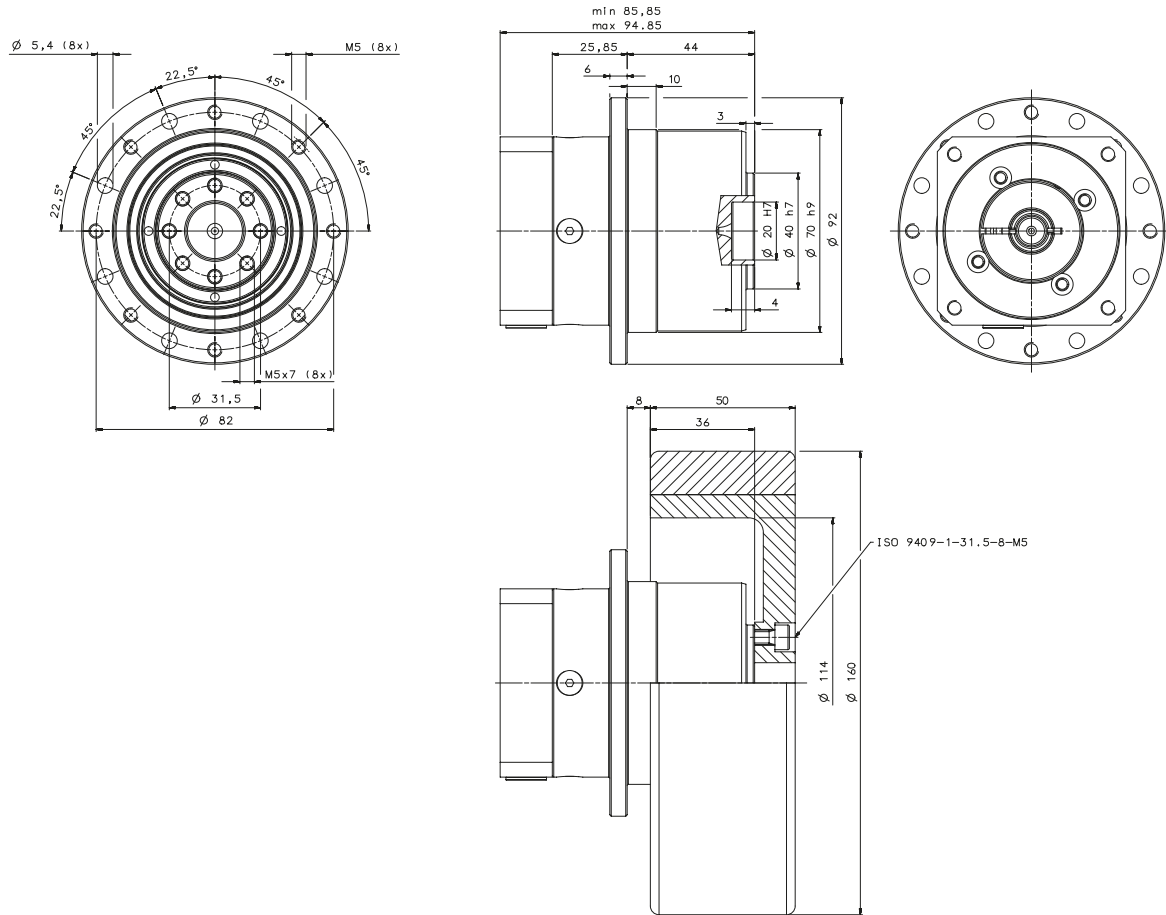

TQW 060		Ratio													Wheel technical data			
		9	12	15	16	20	25	28	30	35	40	50	70	100				
Rated output torque	M_{02} [Nm]	29	29	29	30	30	30	30	29	30	30	30	30	18	Weight	[kg]	2,5	
Maximum acceleration output torque	M_{03} [Nm]	55	55	55	45	45	45	45	55	45	45	45	45	30	Mass inertia	[kgcm ²]	82,8	
Emergency stop output torque ^[1]	M_{04} [Nm]	60	70	70	70	70	70	70	70	70	70	70	70	70	Roll resistance ^[4]	[%]	1	
Nominal input speed	n_1 [min ⁻¹]	3300	3300	3300	3500	3500	3500	3700	4000	4000	4000	4000	4000	4000	Minimum Friction coefficient ^[5]	[-]	0,75	
Maximum momentary input speed ^[2]	n_{max} [min ⁻¹]	4000	4000	4000	5000	5000	5000	6000	6000	6000	6000	6000	6000	6000	Temperature range	[C°]	+30 / -5	
Backlash	ψ_b [arcmin]								10							Tread		Dynaroll
Torsional stiffness	C_t [Nm/arcmin]								6							Tread colour		Black
Maximum radial force ^[3]	R_{max} [N]								2300							Tread Hardness		95° Shore A
Maximum tilting moment applied to the output shaft ^[3]	M_{tilt} [Nm]								108							Rim material		S235JR
Mass moment of inertia at motor shaft	J_k [kgcm ²]								0,06 ... 0,21							Colour		Black
Gearbox weight	m_g [kg]								1,7							Corrosion protection		Standard Painting

[1] Permitted 1000 times during service life of the gearbox.

[2] The speed the unit can be driven at occasionally and in non-repetitive conditions. For S5 duty cycle, it cannot be applied continuously for more than 30 seconds.

[3] Calculated at lifetime of 20000 h - output shaft speed of 100 rpm.

[4] Roll resistance expressed in terms of additional mass percentage to the load applied and at 7,2 km/h.

[5] Static friction coefficient on concrete.

TQW 070

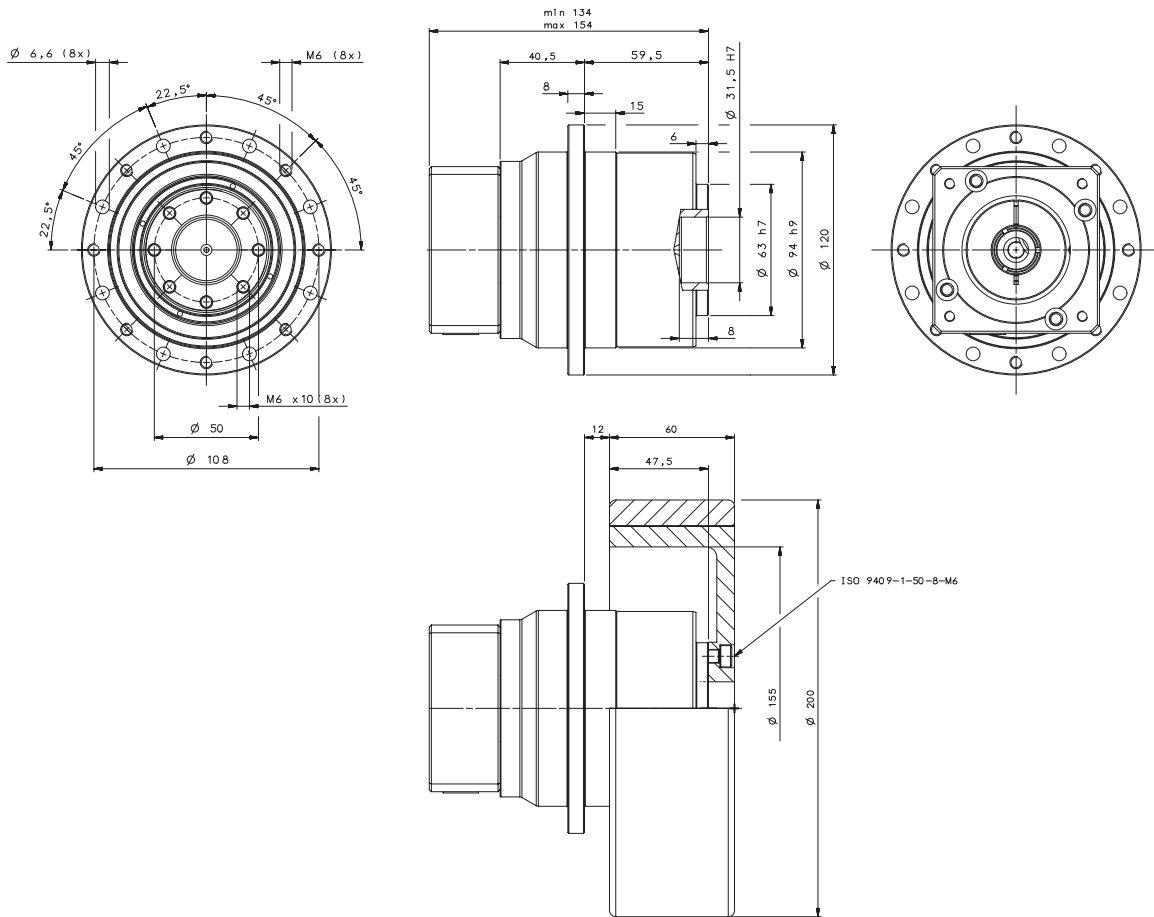

TQW 070		Ratio													Wheel technical data				
		9	12	15	16	20	25	28	30	35	40	50	70	100					
Rated output torque	M_{n2} [Nm]	65	65	65	60	60	50	50	65	50	60	50	50	40	Weight	[kg]	4,3		
Maximum acceleration output torque	M_{a2} [Nm]	120	120	120	110	110	100	100	120	100	110	100	100	70	Mass inertia	[kgcm ²]	258,9		
Emergency stop output torque ^[1]	M_{p2} [Nm]	150	160	160	160	160	160	160	150	160	160	160	160	150	Roll resistance ^[4]	[%]	1		
Nominal input speed	n_1 [min ⁻¹]	3500	3500	3500	3500	3500	3200	4000	4000	4000	4000	4000	4000	4000	Minimum Friction coefficient ^[5]	[-]	0,75		
Maximum momentary input speed ^[2]	n_{1max} [min ⁻¹]	3500	3500	3500	4500	4500	4500	6000	6000	6000	6000	6000	6000	6000	Temperature range	[C°]	+30 / -5		
Backlash	φ_R [arcmin]								10								Tread		Dynaroll
Torsional stiffness	C_t [Nm/arcmin]								23								Tread colour		Black
Maximum radial force ^[3]	R_{2max} [N]								4100								Tread Hardness		95° Shore A
Maximum tilting moment applied to the output shaft ^[3]	M_{T2max} [Nm]								281								Rim material		S235JR
Mass moment of inertia at motor shaft	J_g [kgcm ²]								0,36 ... 0,81								Colour		Black
Gearbox weight	m_g [kg]								5,5								Corrosion protection		Standard Painting

[1] Permitted 1000 times during service life of the gearbox.

[2] The speed the unit can be driven at occasionally and in non-repetitive conditions. For S5 duty cycle, it cannot be applied continuously for more than 30 seconds.

[3] Calculated at lifetime of 20000 h - output shaft speed of 100 rpm.

[4] Roll resistance expressed in terms of additional mass percentage to the load applied and at 7,2 km/h.

[5] Static friction coefficient on concrete.

TQW 090

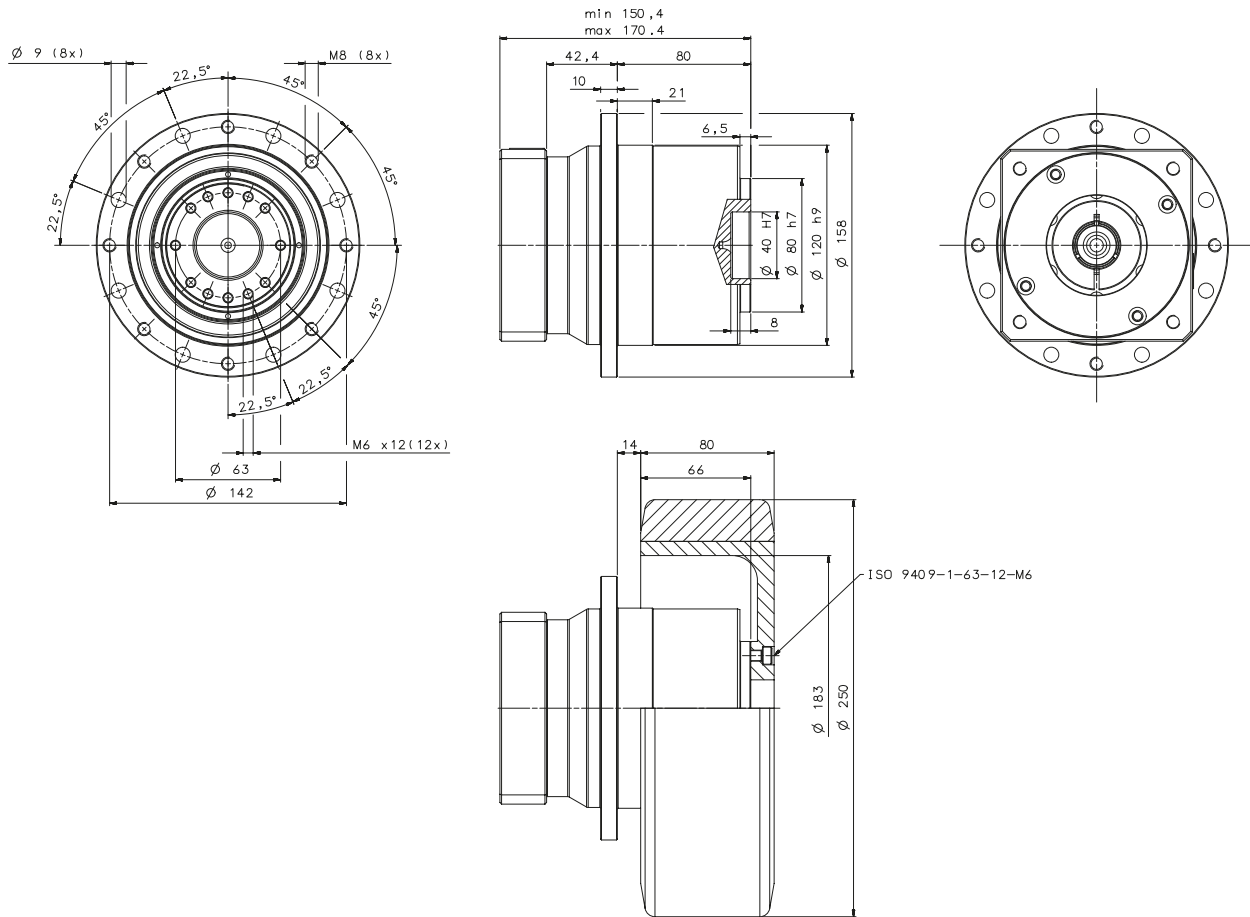

TQW 090		Ratio													Wheel technical data			
		9	12	15	16	20	25	28	30	35	40	50	70	100				
Rated output torque	M_{n2} [Nm]	155	155	155	155	155	125	125	155	125	135	125	125	100	Weight	[kg]	7,2	
Maximum acceleration output torque	M_{a2} [Nm]	280	300	300	300	300	240	240	300	240	300	240	240	160	Mass inertia	[kgcm ²]	619,1	
Emergency stop output torque ^[1]	M_{p2} [Nm]	300	360	360	360	360	360	360	360	360	360	360	360	300	Roll resistance ^[4]	[%]	1	
Nominal input speed	n_1 [min ⁻¹]	3000	3000	3000	3000	3000	3000	3500	3500	3500	3500	3500	3500	3500	Minimum Friction coefficient ^[5]	[-]	0,75	
Maximum momentary input speed ^[2]	n_{1max} [min ⁻¹]	4000	4000	4000	4500	4500	4500	5000	5000	5000	5000	5000	5000	5000	Temperature range	[C°]	+30 / -5	
Backlash	φ_R [arcmin]								10							Tread		Dynaroll
Torsional stiffness	C_t [Nm/arcmin]								50							Tread colour		Black
Maximum radial force ^[3]	R_{2max} [N]								5200							Tread Hardness		95° Shore A
Maximum tilting moment applied to the output shaft ^[3]	M_{T2max} [Nm]								403							Rim material		S235JR
Mass moment of inertia at motor shaft	J_g [kgcm ²]								0,47 ... 3,05							Colour		Black
Gearbox weight	m_g [kg]								10,9							Corrosion protection		Standard Painting

[1] Permitted 1000 times during service life of the gearbox.

[2] The speed the unit can be driven at occasionally and in non-repetitive conditions. For S5 duty cycle, it cannot be applied continuously for more than 30 seconds.

[3] Calculated at lifetime of 20000 h - output shaft speed of 100 rpm.

[4] Roll resistance expressed in terms of additional mass percentage to the load applied and at 7,2 km/h.

[5] Static friction coefficient on concrete.

PERMANENT MAGNET SERVOMOTORS

		BMD 65									BMD 82			BMD 102		BMD 118		
Standstill torque	M_0 [Nm]	0,85			1,70			2,20			3,20	4,40	4,00		5,60			
Rated torque	M_n [Nm]	0,83	0,80	0,76	0,73	1,65	1,60	1,52	1,45	2,12	2,05	1,95	3,15	3,00	4,20	3,70	3,40	5,50
Rated speed	n [min ⁻¹]	1600	3000	4500	6000	1600	3000	4500	6000	1600	3000	4500	1600	3000	1600	1600	3000	1600
Rated frequency	f_n [Hz]	107	200	300	400	107	200	300	400	107	200	300	107	200	107	107	200	107
Rated power	P_n [kW]	0,14	0,25	0,36	0,46	0,28	0,50	0,72	0,91	0,36	0,64	0,92	0,53	0,94	0,70	0,62	1,01	0,92
Max torque	M_{max} [Nm]	2,55			4,90			6,20			8,50	11,5	11,0		15,0			
Number of poles	$2p$ [-]	8			8			8			8	8	8		8			
Motor moment of inertia	J [kg cm ²]	0,2			0,4			0,6			1,4	1,7	1,9		4,5			
Electric time constant	τ_{el} [ms]	3			3			3			5,7	5,7	8,4		13			
Thermal time constant	τ_{therm} [min]	14			20			26			26	33	25		28			
Motor mass without bake/flywheel	m_M [kg]	1,3			1,9			2,6			3,5	4,6	4,2		7,7			
Rated voltage	V_n [V _{AC}]	31	30	32	32	31	30	31	31	31	31	31	31	32	30	31	32	31
Stall RMS current	I_0 [A]	4,04	6,85	9,20	12,0	7,8	13,0	18,0	23,5	10,3	16,6	24,1	15,9	24,8	22,5	19,1	30,0	24,0
Rated RMS current	I_n [A]	3,89	6,46	8,30	10,5	7,75	12,8	17,0	21,0	9,98	15,6	21,2	15,0	23,7	21,1	16,4	26,6	21,7
Max RMS current	I_{max} [A]	13,1	21,7	29,6	38,5	26,7	44,4	61,0	79,5	32,7	52,8	76,0	52,7	85,3	66,8	58,5	96,3	78,7
Back EMF constant phase-phase	K_e [$\frac{mV}{min^{-1}}$]	14,3	8,44	6,29	4,80	14,4	8,64	6,22	4,80	14,9	9,26	6,45	14,5	8,91	13,7	14,9	9,13	16,1
Torque constant	K_T [Nm/A]	0,21	0,12	0,09	0,07	0,22	0,13	0,09	0,07	0,21	0,13	0,09	0,20	0,13	0,20	0,21	0,13	0,23
Stator phase-phase resistance at 20°C	R_{pp} [$\Omega_{20^\circ C}$]	1,76	0,62	0,34	0,20	0,79	0,28	0,15	0,09	0,51	0,20	0,09	0,28	0,11	0,15	0,21	0,08	0,12
Stator phase-phase inductance	L_{pp} [mH]	5,26	1,85	1,02	0,60	2,39	0,86	0,45	0,26	1,56	0,60	0,29	1,59	0,60	0,84	1,78	0,67	1,60

48 Vdc

Our worldwide presence

Thanks to an international network of closely interconnected commercial and production sites, we can guarantee the same high standards of Bonfiglioli quality anywhere at any given time. We know that our direct presence in local markets is the key to long-lasting success, so our family includes 17 production sites, 23 commercial sites and more than 550 distributors around the world.

Our organization is always close by, offering complete and efficient solutions and supporting our customers with dedicated services, co-engineering and after-sales assistance.

17  PRODUCTION SITES

23  COMMERCIAL SITES

80  COUNTRIES

550  DISTRIBUTORS

~5,000  PEOPLE



Bonfiglioli global locations

AUSTRALIA

Bonfiglioli Transmission (Aust.) Pty Ltd
Plumpton NSW



BRAZIL

Bonfiglioli Redutores do Brasil Ltda
São Bernardo do Campo - São Paulo



CHINA

Bonfiglioli Drives (Shanghai) Co. Ltd.
Shanghai



Selcom Electronics (Shanghai) Co., Ltd

Shanghai



Shanghai



FRANCE

Bonfiglioli Transmission S.A.S.

Marly la Ville



GERMANY

Bonfiglioli Deutschland GmbH

Neuss



Bonfiglioli Deutschland GmbH

Krefeld



O&K Antriebstechnik GmbH

Hattingen



INDIA

Bonfiglioli Transmission Ltd.

Mobility & Wind Industries

Thirumudivakkam

Kancheepuram - Tamil Nadu



Industry & Automation Solutions

Mannur Village, Sriperumbudur Taluk

Kancheepuram - Tamil Nadu



Industry & Automation Solutions

Pune - Maharashtra



ITALY

Bonfiglioli Riduttori S.p.A.

Industry & Automation Solutions

Calderara di Reno (BO)



Industry & Automation Solutions

Carpiano



Mobility & Wind Industries

Forlì



Industry & Automation Solutions

Rovereto



Selcom Group S.p.A.

Castel Maggiore (BO)



Castel Maggiore (BO)



Cadriano (BO)



NEW ZEALAND

Bonfiglioli Transmission (Aust.) Pty Ltd

Auckland - Ellerslie



SINGAPORE

Bonfiglioli South East Asia Pte Ltd

Singapore



SLOVAKIA

Bonfiglioli Slovakia s.r.o.

Považská Bystrica



SOUTH AFRICA

Bonfiglioli South Africa Pty Ltd.

Johannesburg



SPAIN

Tecnotrans Bonfiglioli S.A

Castellbisbal - Barcelona



TURKEY

Bonfiglioli Türkiye Jsc

Çiğli - Izmir



UNITED KINGDOM

Bonfiglioli UK Ltd.

Warrington - Cheshire

Tel. +44 1925 852667



USA

Bonfiglioli USA Inc.

Hebron - Kentucky



VIETNAM

Bonfiglioli Vietnam Co. Ltd.

Ben Cat city, Binh Duong province





We have a relentless commitment to excellence, innovation & sustainability. Our team creates, distributes and services world-class power transmission & drive solutions to keep the world in motion.

HEADQUARTERS

Bonfiglioli S.p.A

Via Cav. Clementino Bonfiglioli, 1
40012 Calderara di Reno - Bologna (Italy)
Tel. +39 051 6473111

