



SOLUTIONS FOR

Biogas





We engineer dreams



Contents

BIOGAS.....	5
BIOGAS FROM MUNICIPAL SOLID WASTE	8
BIOGAS FROM AGRI-FOOD AND AGRICULTURAL WASTE	12
COMPLETE SOLUTIONS FOR POWER TRANSMISSION & AUTOMATION	16
OUR GLOBAL PRESENCE.....	18

Engineering Solutions



WWW.BONFIGLIOLI.COM



Biogas

SPECIFIC PRODUCTS AND SOLUTIONS FOR BIOGAS

Biogas is an environmentally-friendly, renewable energy source. It is produced when organic matter, such as food or animal waste, is broken down by microorganisms in the absence of oxygen, in a process called anaerobic digestion.

Biogas can occur naturally or as part of an industrial process to intentionally create it as fuel.

The biogas is then used as a fuel to partially or definitively replace fossil-derived fuel.

Bonfiglioli has designed optimized solutions specific to this kind of installation, which has very stringent requirements in terms of reliability and quality of the components at the heart of transport for biogas production.

Specifically, Bonfiglioli supplies complete solutions for transporting the biomass agitation/heating blades and equipment for biogas production plants, with its complete range of drives and accessories for the transmission of the power required for the operation of the installations.

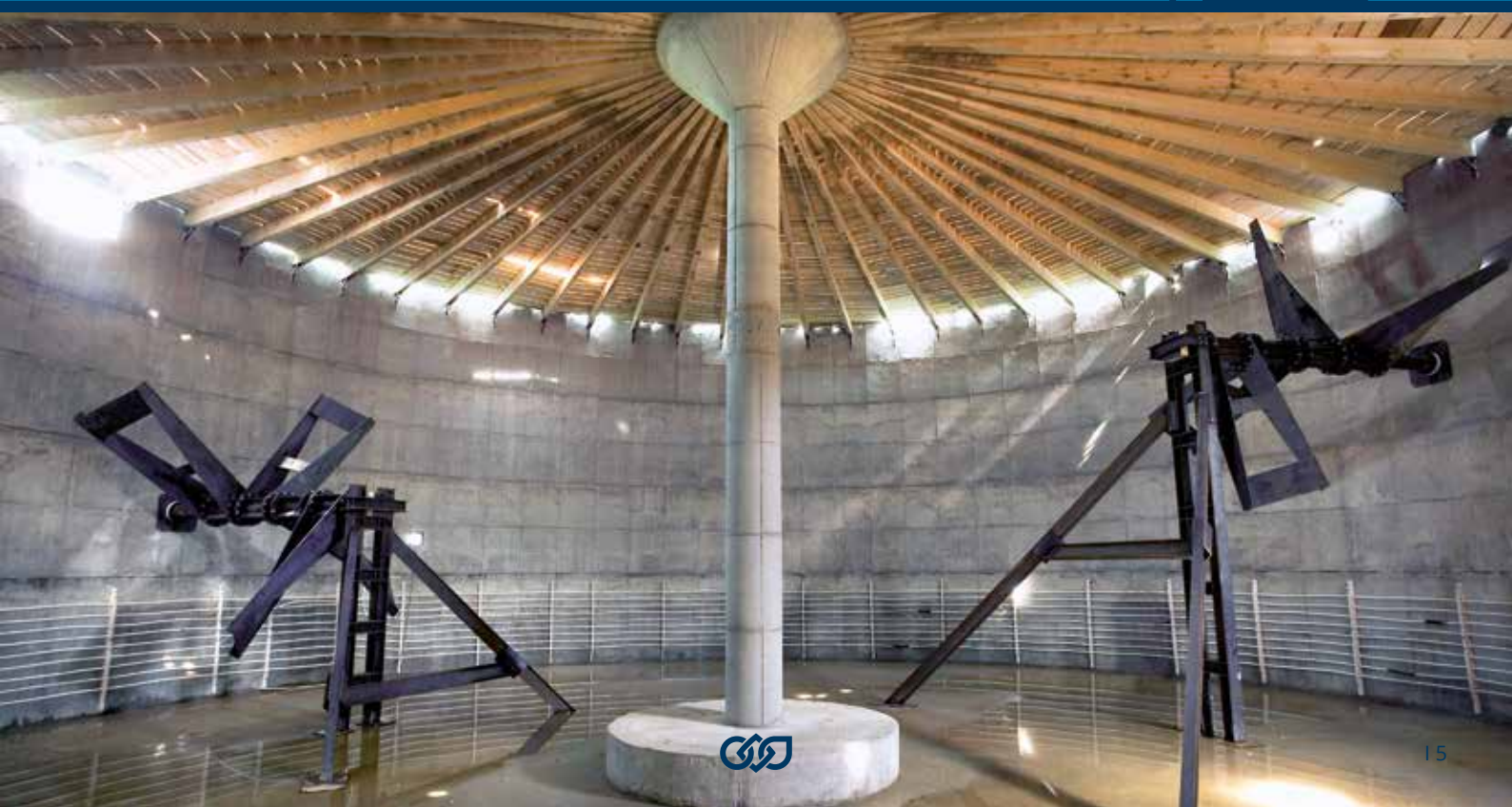

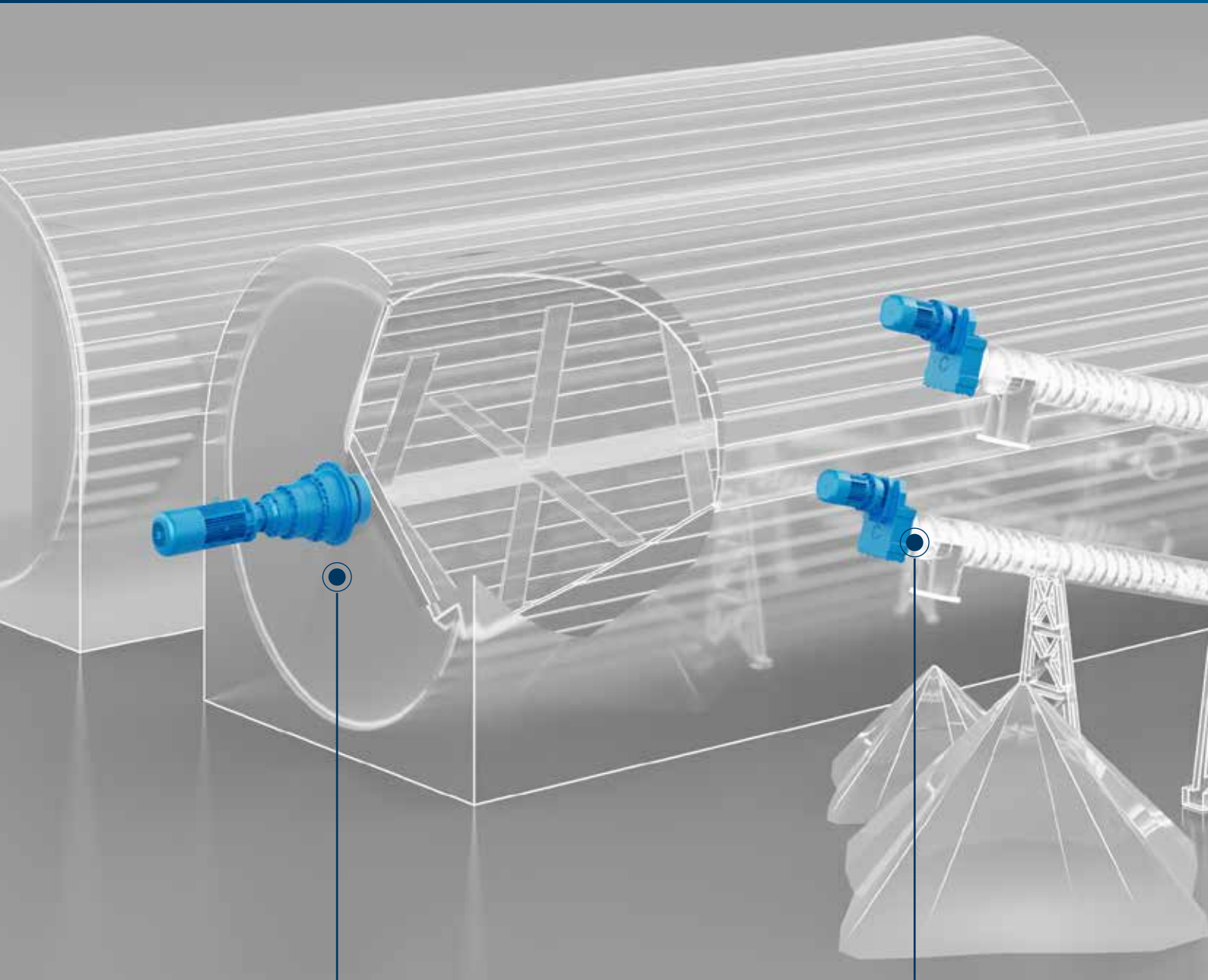

4 ANAEROBIC DIGESTER FOR
MUNICIPAL SOLID WASTE

BIOMASS FEEDER **3**

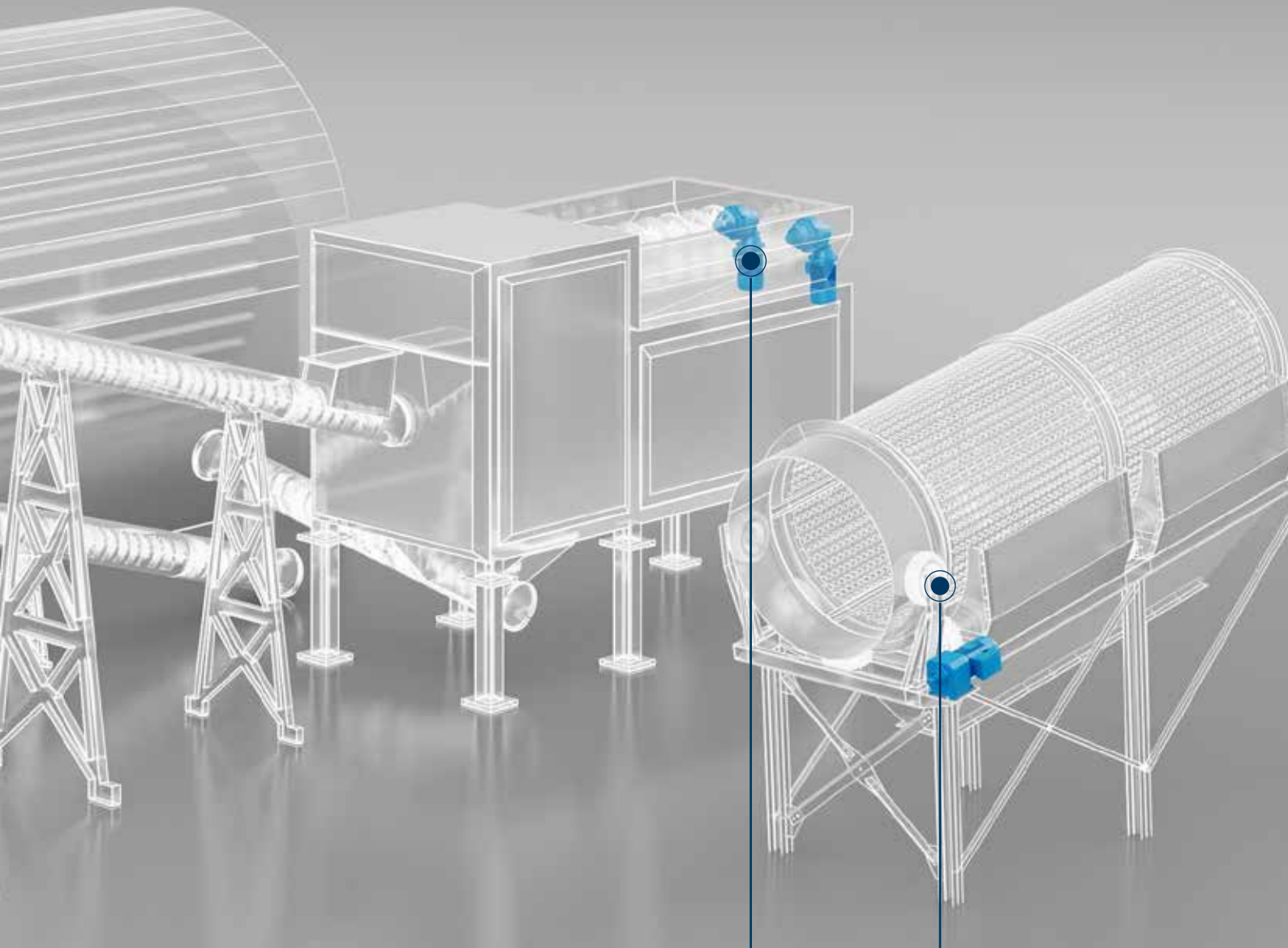

DEPACKAGING AND RECOVERY **1**

2 SIEVING DRUMS

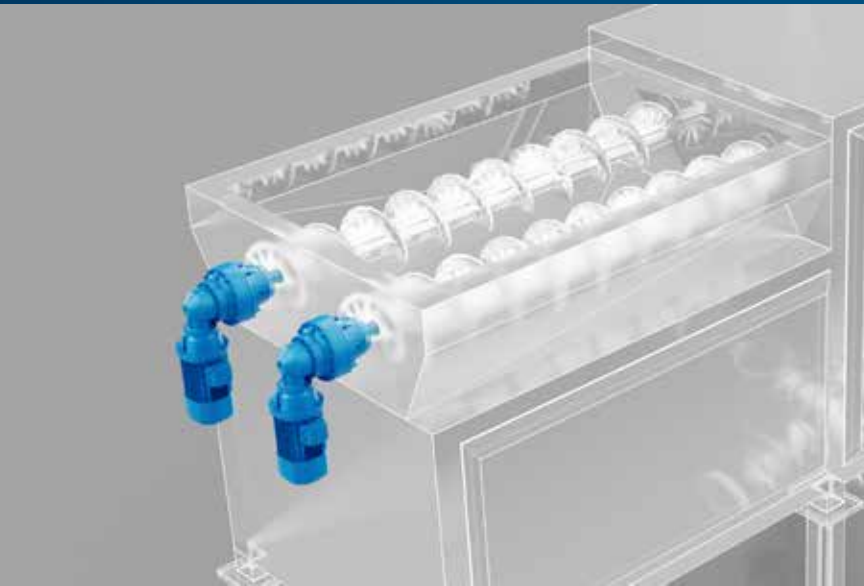

1

DEPACKAGING AND RECOVERY

Shredders reduce the volume of municipal solid waste (MSW), depack the plastic from the waste and select the material with the automatic sorting line. The 300M Series Planetary rating torque guarantees a complete range of shredding machine applications. We supply solutions that ensure speed and precision when handling bulk material.



300M Series Planetary gearbox and geared motor

- High shock load resistance
- Modular design
- Reliable and customized solution for harsh working conditions
- High torque capabilities for low-speed output rotation



EVOX BXN Series Asynchronous Induction Phase Motor

- One motor for different markets
- Simplify installation complexities and inventory management
- Uncompromised Efficiency
- Modular electric motor



AxiaAgile Series Advanced inverter

- Smooth start
- Variable "cut position" for smaller particles

BENEFITS

FEATURES

- Output shaft spline design (according to standard DIN 5480)
- Class C3, C4 and C5 surface protection (according to standard UNI EN ISO 12944-2)
- Customized in combination with other gearbox solutions for higher reduction and output torque

- IE3 Efficiency level
- Power range up to 7,5kW
- Built in DC brake
- Thermal protection
- Anti-condensate heaters
- Second shaft extension
- Anti corrosive painting up to C5M
- Tropicalization
- Degree of protection up to IP56

- CAN open support (variant depending)
- Industrial Ethernet support (variant depending)
- Sensorless control of synchronous, synchronous-reluctance and asynchronous motors
- DC link connection
- Integrated brake chopper
- Power failure control
- Programmable PI Controller
- Integrated PLC (variant-depending)
- Master/slave function with electronic gear
- Integrated safe torque off STO (SIL 3 / PL e / Cat.3) function
- Intelligent current limits
- Output frequency 0...599 Hz, higher frequencies on request
- Diagnosis and setup via optional keypad and Service interface for PC connection

2

SIEVING DRUMS

Sieving drums separate and recover waste by size. EVOX CP solution ensures the continuous operation of the rotating drum in any working condition with high efficiency.

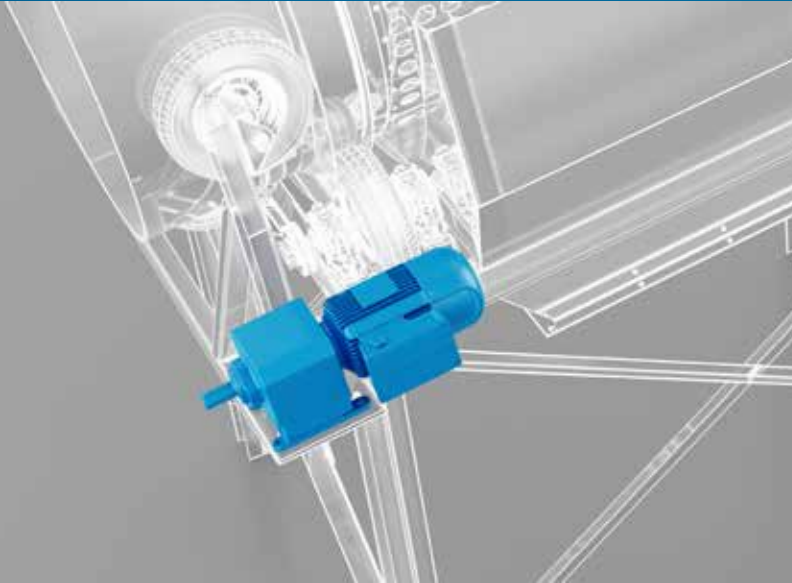

EVOX CP Series
Helical In-Line Gearbox



EVOX MXN Series
Asynchronous Motors



AxiaAgile Series
Advanced inverter

BENEFITS

- Compact design for high torque density and maximum power
- Low warehousing cost, thanks to the distinctive universal mounting
- Safe operation in potentially explosive atmospheres
- Overall dimension in line with market standards
- Easy-Clean shape

FEATURES

- Lifetime lubricated
- Unique oil level for all mounting position
- Stainless steel shaft and plug option
- Reinforced bearings option

- One motor for different markets
- Simplify installation complexities and inventory management
- Uncompromised Efficiency
- Modular electric motor

- IE3 Efficiency level
- Power range up to 7,5kW
- Built in DC brake
- Thermal protection
- Anti-condensate heaters
- Second shaft extension
- Anti corrosive painting up to C5M
- Tropicalization
- Degree of protection up to IP56

- Smooth start
- Variable "cut position" for smaller particles

- CAN open support (variant depending)
- Industrial Ethernet support (variant depending)
- Sensorless control of synchronous, synchronous-reluctance and asynchronous motors
- DC link connection
- Integrated brake chopper
- Power failure control
- Programmable PI Controller
- Integrated PLC (variant-depending)
- Master/slave function with electronic gear
- Integrated safe torque off STO (SIL 3 / PL e / Cat.3) function
- Intelligent current limits
- Output frequency 0...599 Hz, higher frequencies on request
- Diagnosis and setup via optional keypad and Service interface for PC connection

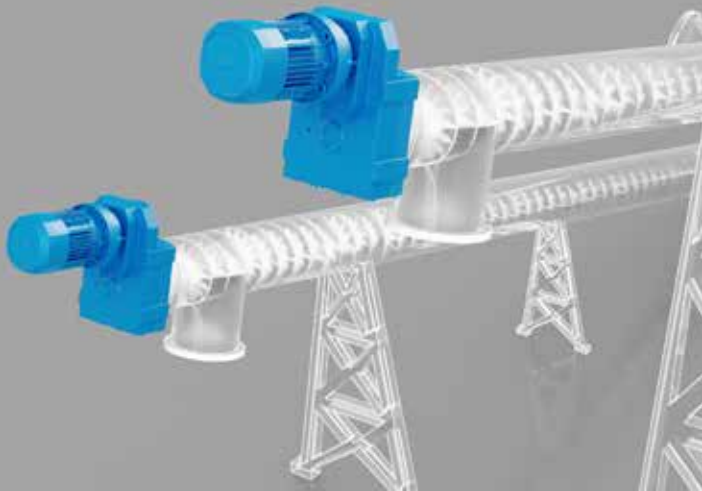

3

BIOMASS FEEDER

The Biomass Feeder is the starting point of the biogas production chain, designed to introduce solid or semi-liquid biomass into the anaerobic digester in a controlled, continuous, and reliable manner.

Key features include high resistance to harsh environmental conditions such as humidity, corrosion, and abrasive materials, as well as continuous operation to prevent blockages or overloads that could affect digester performance.



F Series Shaft Mounted Gearbox

- High efficiency
- Reliability and robustness
- Compactness
- Low maintenance



EVOX BXN Series Asynchronous Induction Phase Motor

- One motor for different markets
- Simplify installation complexities and inventory management
- Uncompromised Efficiency
- Modular electric motor



AxiaAgile Series Advanced inverter

- Smooth start
- Variable "cut position" for smaller particles

BENEFITS

FEATURES

- Shaft mounted solution with different output configurations
- Housing integrated torque arm design and anti-vibration kits
- Wide range of ratios
- Availability of different grade of protection
- Compact or IEC/NEMA flanged motor adaptors
- Fluoroelastomer and double lip seals

- IE3 Efficiency level
- Power range up to 7,5kW
- Built in DC brake
- Thermal protection
- Anti-condensate heaters
- Second shaft extension
- Anti corrosive painting up to C5M
- Tropicalization
- Degree of protection up to IP56

- CAN open support (variant depending)
- Industrial Ethernet support (variant depending)
- Sensorless control of synchronous, synchronous-reluctance and asynchronous motors
- DC link connection
- Integrated brake chopper
- Power failure control
- Programmable PI Controller
- Integrated PLC (variant depending)
- Master/slave function with electronic gear
- Integrated safe torque off STO (SIL 3 / PL e / Cat.3) function
- Intelligent current limits
- Output frequency 0...599 Hz, higher frequencies on request
- Diagnosis and setup via optional keypad and Service interface for PC connection

4

ANAEROBIC DIGESTER FOR MUNICIPAL SOLID WASTE

The Anaerobic Digester consists of slowly rotating paddle agitator that ensures optimum mixing of the digestate.

The 300M Series Planetary guarantees high peak load capacity, the best in class in terms of mechanical performances.

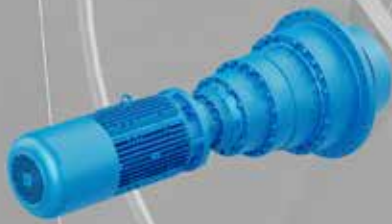

300M Series
Planetary Gearbox



BX Series
Asynchronous induction
phase motor



AxiaAgile Series
Advanced inverter

BENEFITS

- Robustness
- Reliability in harsh working conditions & wide range of temperature
- High torque density
- Modularity
- High overhung load capacity

- Reliable, balanced and robust
- Compliant with the most of the efficiency standards

- Smooth start
- Variable "cut position" for smaller particles

FEATURES

- Widest range of ratios
- Easy to fit output pinion
- IEC or NEMA motor flange
- Wide range of motion control solutions
- Availability of different grades of protection
- Fluoroelastomer and double lip seals

- Power range up to 22kW
- Built in DC brakes
- Thermal protection
- Anti-condensate heaters
- Second shaft extension
- Anti corrosive painting up to C5M
- Tropicalization
- Degree of protection up to IP56

- CAN open support (variant depending)
- Industrial Ethernet support (variant depending)
- Sensorless control of synchronous, synchronous-reluctance and asynchronous motors
- DC link connection
- Integrated brake chopper
- Power failure control
- Programmable PI Controller
- Integrated PLC (variant-depending)
- Master/slave function with electronic gear
- Integrated safe torque off STO (SIL 3 / PL e / Cat.3) function
- Intelligent current limits
- Output frequency 0...599 Hz, higher frequencies on request
- Diagnosis and setup via optional keypad and Service interface for PC connection

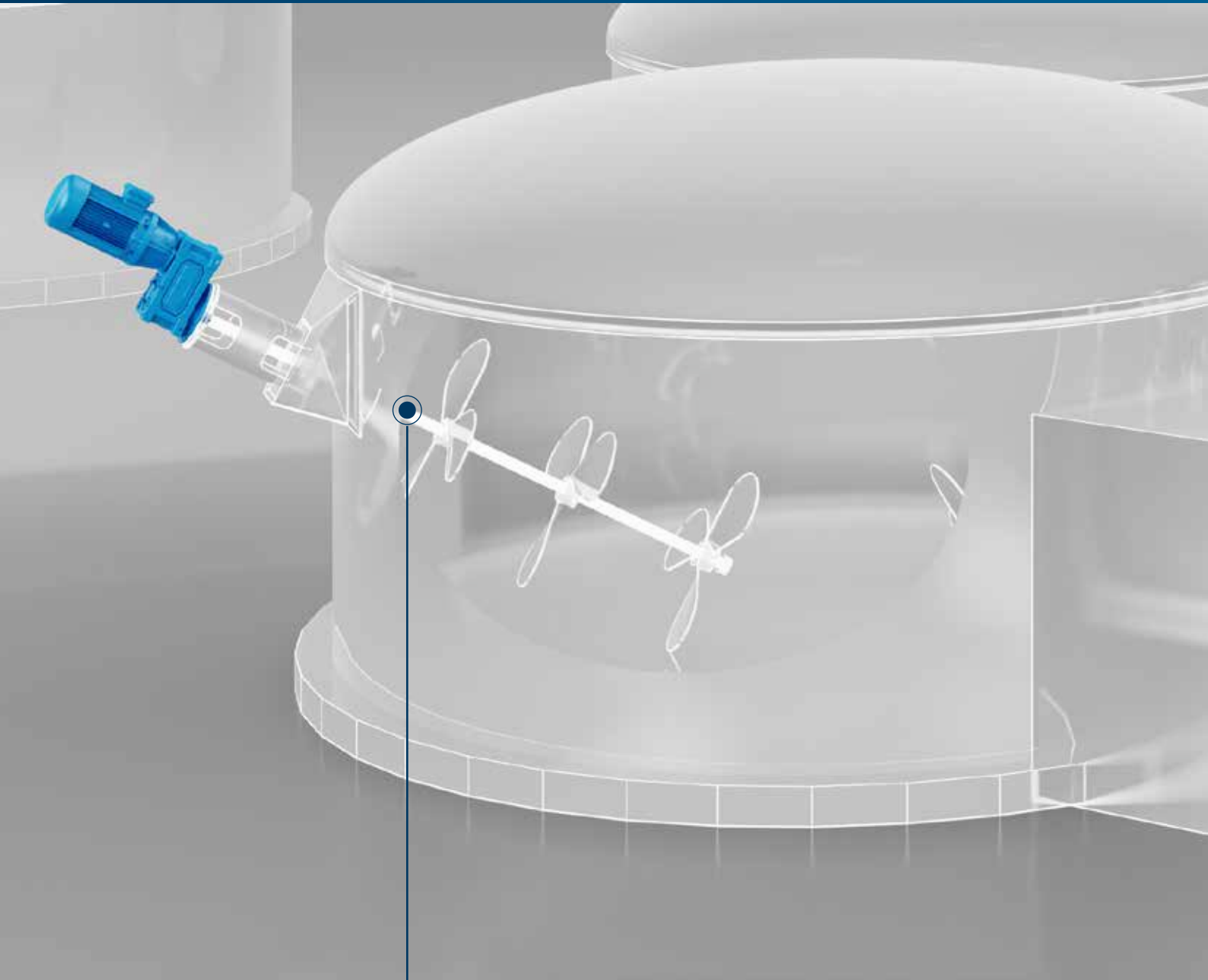

1 BIOMIXERS AND AGITATORS

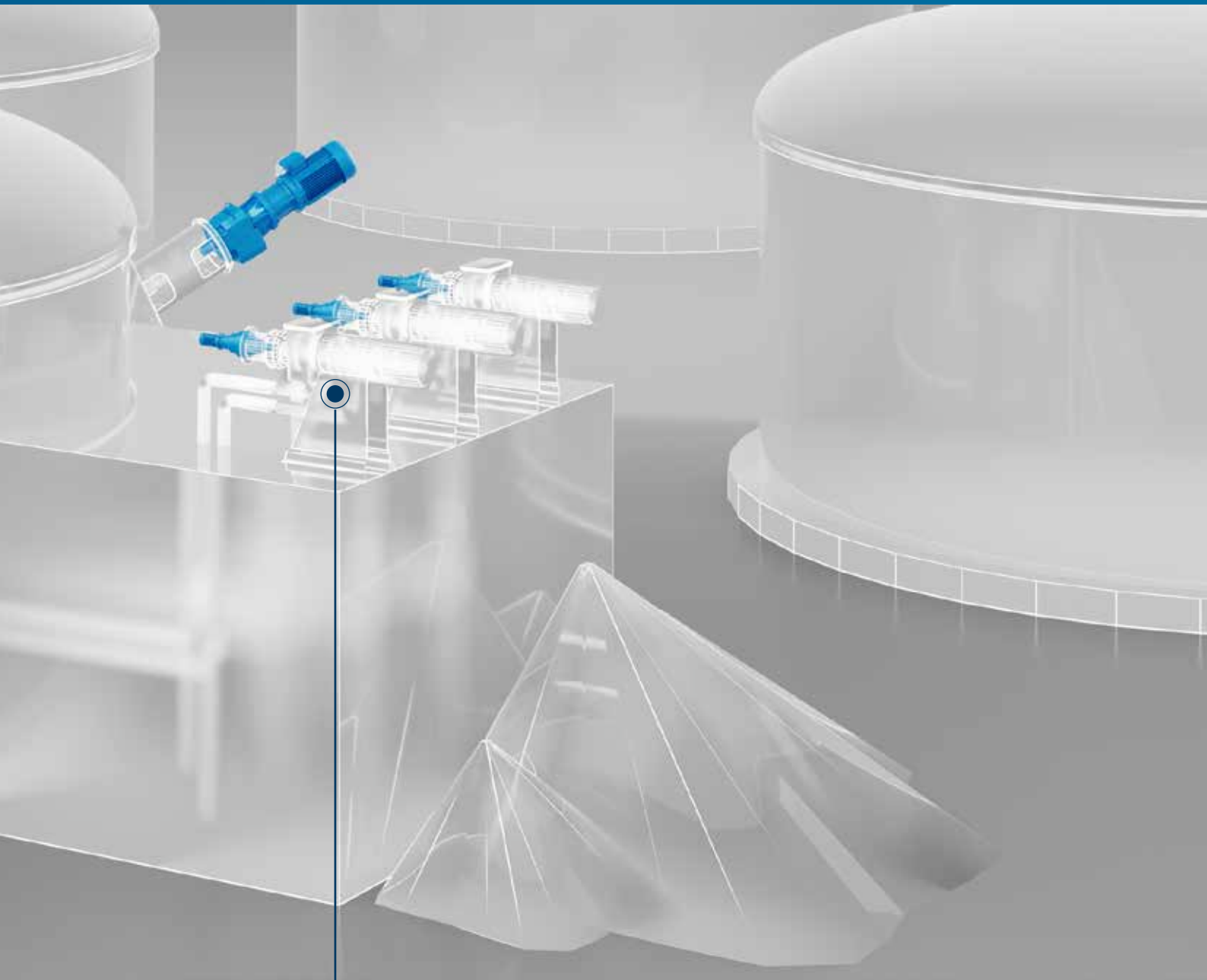

2 SEPARATOR



1

BIOMIXERS AND AGITATORS

Biomixers and agitators play a critical role in maintaining optimal fermentation conditions inside anaerobic digesters. They ensure the homogeneous distribution of biomass, improve gas release efficiency, and prevent the formation of floating layers or sedimentation.

The HDP heavy-duty gearbox offers high torque and durability for demanding mixing conditions.

The 300M Series is a compact, modular option ensuring efficient power transmission for both horizontal and inclined setups.



300M Series Planetary Gearbox

- Robustness
- Reliability in harsh working conditions & wide range of temperature
- High torque density
- Modularity
- High overhung load capacity



HDP Series Heavy Duty Geared Motor (Helical- Parallel)

- Robustness
- Reliability in harsh working conditions and wide range of temperature
- Space effective U-shape arrangement
- High overhung load capacity
- Tailored service and warranty plans
- Pre-sales and product definition support according to the material handling and lifting standards



BX Series Asynchronous induction phase motor

- Reliable, balanced and robust
- Compliant with the most of the efficiency standards



AxiaAgile Series Advanced inverter

- Smooth start
- Variable "cut position" for smaller particles
- CAN open support (variant depending)
- Industrial Ethernet support (variant depending)
- Sensorless control of synchronous, synchronous-reluctance and asynchronous motors
- DC link connection
- Integrated brake chopper
- Power failure control
- Programmable PI Controller
- Integrated PLC (variant depending)
- Master/slave function with electronic gear
- Integrated safe torque off STO (SIL 3 /PL e / Cat.3) function
- Intelligent current limits
- Output frequency 0...599 Hz, higher frequencies on request
- Diagnosis and setup via optional keypad and Service interface for PC connection

BENEFITS

FEATURES

- Widest range of ratios
- Easy to fit output pinion
- IEC or NEMA motor flange
- Wide range of motion control solutions
- Availability of different grades of protection
- Fluoroelastomer and double lip seals

- Double input and output shaft
- Wide range of ratios
- Transmissible torque up to 210.000 Nm
- IEC or NEMA motor flange
- Safety solutions according to the customer requirements
- Wide range of motion control solutions
- Availability of different grade of protection

- Power range up to 22kW
- Built in DC brakes
- Thermal protection
- Anti-condensate heaters
- Second shaft extension
- Anti corrosive painting up to C5M
- Tropicalization
- Degree of protection up to IP56

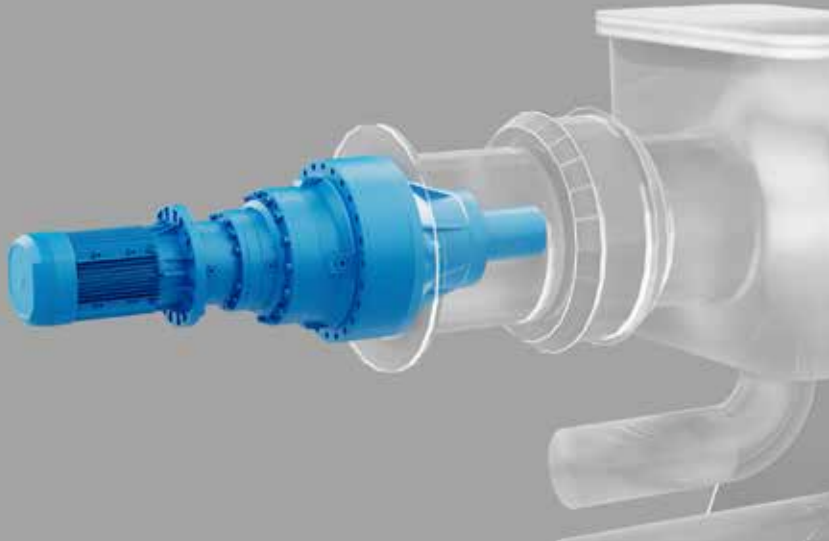

2

SEPARATOR

The press screw is used to separate liquid from organic solid waste.

The 300M Series Gearbox guarantees a compact, easy to install design. The reliable operation of the system is also assured by the control and regulation of the Agile series Inverter unit, for a wide range of throughput capacities.



300M Series
Planetary Gearbox



EVOX BXN Series
Asynchronous Induction
Phase Motor



AxiaAgile Series
Advanced inverter

BENEFITS

- Robustness
- Reliability in harsh working conditions & wide range of temperature
- High torque density
- Modularity
- High overhung load capacity

FEATURES

- Widest range of ratios
- Easy to fit output pinion
- IEC or NEMA motor flange
- Wide range of motion control solutions
- Availability of different grades of protection
- Fluoroelastomer and double lip seals

- One motor for different markets
- Simplify installation complexities and inventory management
- Uncompromised Efficiency
- Modular electric motor

- IE3 Efficiency level
- Power range up to 7,5kW
- Built in DC brake
- Thermal protection
- Anti-condensate heaters
- Second shaft extension
- Anti corrosive painting up to C5M
- Tropicalization
- Degree of protection up to IP56

- Smooth start
- Variable "cut position" for smaller particles

- CAN open support (variant depending)
- Industrial Ethernet support (variant depending)
- Sensorless control of synchronous, synchronous-reluctance and asynchronous motors
- DC link connection
- Integrated brake chopper
- Power failure control
- Programmable PI Controller
- Integrated PLC (variant-dependending)
- Master/slave function with electronic gear
- Integrated safe torque off STO (SIL 3 / PL e / Cat.3) function
- Intelligent current limits
- Output frequency 0...599 Hz, higher frequencies on request
- Diagnosis and setup via optional keypad and Service interface for PC connection



GEAR UNITS

HEAVY DUTY

Helical parallel shaft gear units | **HDP Series**

- **Torque range:** 5,190 to 147,070 Nm
- **Gear ratios:** 7.1 to 500

Planetary gear units | **300M Series**

- **Torque range:** 1,250 to 1,286,000 Nm
- **Gear ratios:** 3.4 ... 2,916

LIGHT DUTY

Helical in-line gearbox | **EVOX CP Series**

- **Torque range:** 55 to 335 Nm
- **Gear ratios:** 2.3 to 172

Helical parallel gear units | **F Series**

- **Torque range:** 140 to 14,000 Nm
- **Gear ratios:** 6.4 to 2,188

ELECTRIC MOTORS

Asynchronous IEC motors | **BX Series**

A complete range of AC motors, meeting basic worldwide MEPS (e.g. IE3)

- **Power range:** 0.75 to 315 kW
- **Poles:** 4

IE3

Asynchronous IEC motors | **eVOX BXN Series**

Asynchronous compact motors | **eVOX MXN Series**

A complete range of AC motors, meeting application worldwide MEPS (e.g. IE3)

- **Power range:** 0.12 to 7.5 kW
- **Poles:** 4

IE3



INVERTERS

HEAVY DUTY

Advanced inverter | **AxiaAgile Series**

- **AXA20:** 0.12 - 3 kW / 1-phase | 0.25 - 7.5 kW / 3-phase 230 V
- **AXA40:** 0.25 - 11 kW / 3-phase 380...480 V

LIGHT DUTY

Advanced inverter | **AxiaAgile Series**

- **AXA20:** 0.12 - 3 kW / 1-phase | 0.25 - 7.5 kW / 3-phase 230 V
- **AXA40:** 0.25 - 11 kW / 3-phase 380...480 V

Our worldwide presence

Thanks to an international network of closely interconnected commercial and production sites, we can guarantee the same high standards of Bonfiglioli quality anywhere at any given time. We know that our direct presence in local markets is the key to long-lasting success, so our family includes 17 production sites, 23 commercial sites and more than 550 distributors around the world.

Our organization is always close by, offering complete and efficient solutions and supporting our customers with dedicated services, co-engineering and after-sales assistance.

17  PRODUCTION SITES

23  COMMERCIAL SITES

80  COUNTRIES

550  DISTRIBUTORS

~5,000  PEOPLE



Bonfiglioli global locations

AUSTRALIA

Bonfiglioli Transmission (Aust.) Pty Ltd
Plumpton NSW



BRAZIL

Bonfiglioli Redutores do Brasil Ltda
São Bernardo do Campo - São Paulo



CHINA

Bonfiglioli Drives (Shanghai) Co. Ltd.
Shanghai



Selcom Electronics (Shanghai) Co., Ltd

Shanghai



Shanghai



FRANCE

Bonfiglioli Transmission S.A.S.

Marly la Ville



GERMANY

Bonfiglioli Deutschland GmbH

Neuss



Bonfiglioli Deutschland GmbH

Krefeld



O&K Antriebstechnik GmbH

Hattingen



INDIA

Bonfiglioli Transmission Ltd.

Mobility & Wind Industries

Thirumudivakkam

Kancheepuram - Tamil Nadu



Industry & Automation Solutions

Mannur Village, Sriperumbudur Taluk

Kancheepuram - Tamil Nadu



Industry & Automation Solutions

Pune - Maharashtra



ITALY

Bonfiglioli Riduttori S.p.A.

Industry & Automation Solutions

Calderara di Reno (BO)



Industry & Automation Solutions

Carpiano



Mobility & Wind Industries

Forlì



Industry & Automation Solutions

Rovereto



Selcom Group S.p.A.

Castel Maggiore (BO)



Castel Maggiore (BO)



Cadriano (BO)



NEW ZEALAND

Bonfiglioli Transmission (Aust.) Pty Ltd

Auckland - Ellerslie



SINGAPORE

Bonfiglioli South East Asia Pte Ltd

Singapore



SLOVAKIA

Bonfiglioli Slovakia s.r.o.

Považská Bystrica



SOUTH AFRICA

Bonfiglioli South Africa Pty Ltd.

Johannesburg



SPAIN

Tecnotrans Bonfiglioli S.A

Castellbisbal - Barcelona



TURKEY

Bonfiglioli Türkiye Jsc

Çiğli - Izmir



UNITED KINGDOM

Bonfiglioli UK Ltd.

Warrington - Cheshire

Tel. +44 1925 852667



USA

Bonfiglioli USA Inc.

Hebron - Kentucky



VIETNAM

Bonfiglioli Vietnam Co. Ltd.

Ben Cat city, Binh Duong province





We have a relentless commitment to excellence, innovation & sustainability. Our team creates, distributes and services world-class power transmission & drive solutions to keep the world in motion.

HEADQUARTERS

Bonfiglioli S.p.A

Via Cav. Clementino Bonfiglioli, 1
40012 Calderara di Reno - Bologna (Italy)
Tel. +39 051 6473111

