



Solutions for Heavy Industry



MARKETS &
APPLICATIONS





Bonfiglioli solutions for heavy industry

Among Bonfiglioli product portfolio, a wide range of solutions is dedicated to heavy industry applications. By offering complete solutions (gearboxes-motors-inverters), we are able to satisfy all the market requirements in terms of robustness, quality and superior reliability.

Operating from the Bonfiglioli many subsidiaries around the world, our technical service is always available to support customers in selecting the most suitable type and size of product for the application at hand.



A One-Stop shop for all your industrial applications

Every year, Bonfiglioli manufactures over 1.5 million products offering its customers fully integrated and solutions, ideal for a wide range of applications in over twenty industrial sectors.

With more than 60 years of experience, our extensive range of gearboxes, gearmotors, electric motors and inverters offers the opportunity to benefit from exceptional technical characteristics and superb performance in all industrial applications.

Our mechatronic solutions for industrial automation deliver the highest possible level of precision, efficiency and energy optimization. These solutions include precision planetary gearboxes, servomotors, open and closed loop inverters, servo inverters and regenerative inverters.



MEET OUR
CUSTOMERS'
NEEDS



WORLDWIDE
DISTRIBUTION
NETWORK



IMPROVE
APPLICATION
PERFORMANCE

Always by our customer's side, all over the world

Bonfiglioli has globalized production over the years. Today, we operate 14 manufacturing plants around the world to serve customers in local markets more effectively. Our plants in Italy, Germany, USA, Brazil, India, China, Vietnam, and Slovakia form a truly efficient distribution network.

Excellence is our number one priority.

We use the latest technologies to optimize our daily production. Bonfiglioli is fully committed to a more sustainable workplace and supports various local initiatives.

All Bonfiglioli employee pay the utmost attention to even the smallest details, to ensure that our customers receive products with unrivalled quality.



**LEAN
MANUFACTURING**



INDUSTRY 4.0



**FAST DELIVERY
TIMES**



**WORLDWIDE
PRESENCE**

Sharing the value of our work with you

Our team is fully dedicated to continuous improvement in the fields of quality, safety and the environment, across the entire value chain, from the smallest supplier to the end customer.

Bonfiglioli management systems are certified to ISO 9001:2008, ISO 14001 and OHSAS 18001, while our products are covered by 7 international certifications.

Responsibility, excellence and continuous improvement are some of the basic elements that make Bonfiglioli a preferred partner.

SYSTEM CERTIFICATIONS:



PRODUCT CERTIFICATIONS:



Heavy machinery has Bonfiglioli products at its heart

The HDP parallel shaft, HDO right-angle and 300 planetary series offer designers the ultimate flexibility in build architecture and transmissible power range.

For every installation, cooling or lubrication requirement, each gearmotor can easily be rendered fit-for-purpose through the long, complete list of standard options and accessories.

Logistics

(belt, chain, bucket, screw conveyors, gantry and trolley drives, etc.)

Winch and Lift

(cranes, hoists, winches, etc.)

Packaging

(filling machines, palletizers, stackers, etc.)

Raw material and resources

(metals, petroleum, forestry, rubber, plastics, cement, sand & stone, etc.)

Mining

(ore crushers, apron and screw feeders, bucket elevators, mills and kilns, etc.)

Purification and Production

(pulp and paper, air cooling, sewage, recycling, etc.)



Product reliability is achieved through a production process geared towards excellence

All essential parts are produced in Bonfiglioli's own plant using constantly updated machine tools of the latest generation.

Machining technology is therefore fully owned by Bonfiglioli and part of a know-how acquired over 50 years of manufacturing.

Today, precision machining is very much a part of Bonfiglioli's consolidated heritage.

The CNC machine tools and equipment used for the production of gears and other essential component parts are all state-of-the-art in terms of quality, efficiency and productivity in general.

Advanced machinery has always been central to Bonfiglioli's production system and Bonfiglioli has always assigned top priority to the quality and efficiency of its machine park, and has invested accordingly.



Bonfiglioli products



300M

Planetary gearmotors

The planetary drives from the 300 series are particularly suitable for power transmission in applications for mixing fermenting matter.

The vertical configuration for the agitators and right angle configuration for the mixers, typical of the installation management processes, are available as part of the standard offer.

In particular, vertical mounting significantly reduces the dimensions of the drive, ensuring high torque and excellent performance in this application type.

300 Series planetary gearboxes are extremely compact despite their outstanding transmissible torque characteristics and overload capacity typical of "Heavy Duty" applications.

Superb flexibility is ensured by a large number of optional variants that can be selected directly from the catalogue and that allow gearbox configurations to be customised to meet the needs of specific applications.

Type	Torque [Nm]
300	1 250
301	2 460
303	2 970
304	3 960
305	5 800
306	10 840
307	15 680
309	23 240
310M	33 460
311M	49 210
313M	60 940
314M	80 640
315M	100 800
316M	134 390
317M	207 490
318M	297 550
319	471 190
321	655 740
323	890 310
325	1 286 000

Torque range

1 250 ... 1 286 000 Nm

Mechanical rating

up to 1 050 kW

Gear ratios

3.4 ... 5234

 ATEX GEARBOX AVAILABLE

HDO

Bevel Helical Gearbox

The bevel helical gear reducer series from Bonfiglioli optimises superior performance with compact dimensions and flexibility. The several options that can be selected from the catalogue facilitate customization to meet specific application requirements.

Gear case from nodular cast iron guarantee rigidity in all circumstances, while the gears - integrally ground finished on their profile - ensure quiet and vibration-free operations even in the harshest conditions.



Torque range

8 990 ... 209 900 Nm

Gear ratios

5.6 ... 490

Mounting

Foot, flange, shaft mounting



ATEX GEARBOX AVAILABLE

Type	Torque [Nm]
HDO 71	8 990
HDO 81	14 740
HDO 91	21 610
HDO 95	23 200
HDO 100	28 210
HDO 110	31 790
HDO 120	41 250
HDO 125	49 240
HDO 130	69 570
HDO 140	87 060
HDO 150	117 200
HDO 160	147 070
HDO 170	190 190
HDO 180	209 900

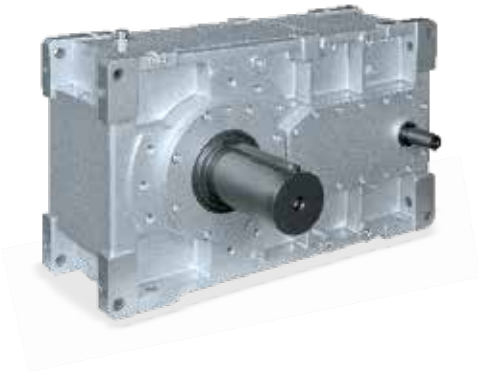

HDP

Parallel Shaft Gearbox

Consistently high torque ratings, gear ratios in close progression, numerous mounting options along with compact dimensions will ease the engineering of any application.

The housing from nodular cast iron ensures robustness even in the harshest environment and the class of precision the gear are machined into helps produce an extremely quiet and vibration-free operation.

Type	Torque [Nm]
HDP 60	5 190
HDP 70	7 080
HDP 80	12 600
HDP 90	17 900
HDP 100	28 210
HDP 110	31 790
HDP 120	41 250
HDP 125	49 240
HDP 130	69 570
HDP 140	87 060
HDP 150	117 200
HDP 160	147 070
HDP 170	190 190
HDP 180	209 900

Torque range

5 190 ... 209 900 Nm

Gear ratios

7.1 ... 500

Mounting

Foot, flange, shaft mounting



ATEX GEARBOX AVAILABLE

Active

Powerful Drive

A full series of flexible solution drives that are versatile and extremely easy to use, featuring control for high performance and unbeatable advantages in their scalability and compact size.



Power range

ACT 410: 0.55 ... 132 kW

ACT 210: 0.55 ... 9.2 kW

Overload Capacity

150% for 60 s; 200% for 1 s

Switching Frequency

2, 4, 8, 12, 16 kHz

Enclosure

IP20 (EN 60529)

EMC Filter

Integrated up to 9.2 kW (EN 61800-3)

Type	Power kW
ACT410-05	0.55
ACT410-07	0.75
ACT410-09	1.1
ACT410-11	1.5
ACT410-12	1.85
ACT410-13	2.2
ACT410-15	3.0
ACT410-18	4.0
ACT410-19	5.5
ACT410-21	7.5
ACT410-22	9.2
ACT410-23	11
ACT410-25	15
ACT410-27	18.5
ACT410-29	22
ACT410-31	30
ACT410-33	37
ACT410-35	45
ACT410-37	55
ACT410-39	65
ACT410-43	75
ACT410-45	90
ACT410-47	110
ACT410-49	132

ACT210-05	0.55
ACT210-07	0.75
ACT210-09	1.1
ACT210-11	1.5
ACT210-13	2.2
ACT210-15	3.0
ACT210-18	4.0
ACT210-19	5.5
ACT210-21	7.5
ACT210-22	9.2



Active Cube

High Positioning & Speed Control

A full series of solution & servo drives, compact and flexible, dedicated both to high demanding industrial automation systems and to motion control architectures, in match with Bonfiglioli servomotors.

Type	Power kW
ACU410-01	0.25
ACU410-03	0.37
ACU410-05	0.55
ACU410-07	0.75
ACU410-09	1.1
ACU410-11	1.5
ACU410-12	1.85
ACU410-13	2.2
ACU410-15	3.0
ACU410-18	4.0
ACU410-19	5.5
ACU410-21	7.5
ACU410-22	9.2
ACU410-23	11
ACU410-25	15
ACU410-27	18.5
ACU410-29	22
ACU410-31	30
ACU410-33	37
ACU410-35	45
ACU410-37	55
ACU410-39	65
ACU410-43	75
ACU410-45	90
ACU410-47	110
ACU410-49	132
ACU410-51	160
ACU410-51	200
ACU410-51	160
ACU410-53	200
ACU410-55	250
ACU410-57	315
ACU410-59	355
ACU410-61	400

Power range

ACU 410: 0.25 ... 400 kW (1200 kW in parallel connection)
 ACU 210: 0.25 ... 9.2 kW

Overload Capacity

150% for 60 s; 200% for 1 s

Switching Frequency

2, 4, 8, 12, 16 kHz

Enclosure

IP20 (EN 60529), IP 54 available

EMC Filter

Integrated up to 9.2 kW (EN 61800-3)

Type	Power kW
ACU210-01	0.25
ACU210-03	0.37
ACU210-05	0.55
ACU210-07	0.75
ACU210-09	1.1
ACU210-11	1.5
ACU210-13	2.2
ACU210-15	3.0
ACU210-18	4.0
ACU210-19	5.5
ACU210-21	7.5
ACU210-22	9.2

Global Presence



Bonfiglioli is a market force with a presence spanning 22 countries on 5 continents. Our organization makes the most of geographic proximity to offer complete solutions combining efficiency and competence.



3804
EMPLOYEES



20
BRANCHES



13
PLANTS



550
DISTRIBUTORS



80
COUNTRIES

We Are a Global Company

Thanks to an international network of sales branches and closely interconnecting production plants, we can guarantee the same high standards of Bonfiglioli quality anywhere at any given time. Aware that our direct presence in local markets is the key to long-lasting success, our family includes 20 sales branches, 13 production plants and more than 500 distributors around the world.

Our organization is always close by, offering complete and efficient solutions and supporting our customers with dedicated services, such as co-engineering or after-sales assistance.



Bonfiglioli Worldwide Locations

Australia

Bonfiglioli Transmission (Aust.) Pty Ltd
2, Cox Place Glendenning NSW 2761
Locked Bag 1000 Plumpton NSW 2761
Tel. +61 2 8811 8000



Brazil

Bonfiglioli Redutores do Brasil Ltda
Travessa Cláudio Armando 171 - Bloco 3
CEP 09861-730 - Bairro Assunção
São Bernardo do Campo - São Paulo
Tel. +55 11 4344 2322



China

Bonfiglioli Drives (Shanghai) Co. Ltd.
#68, Hui-Lian Road, QingPu District,
201707 Shanghai
Tel. +86 21 6700 2000



France

Bonfiglioli Transmission s.a.
14 Rue Eugène Pottier
Zone Industrielle de Moimont II
95670 Marly la Ville
Tel. +33 1 34474510



Germany

Bonfiglioli Deutschland GmbH
Sperberweg 12 - 41468 Neuss
Tel. +49 0 2131 2988 0



Bonfiglioli Vectron GmbH

Europark Fichtenhain B6 - 47807 Krefeld
Tel. +49 0 2151 8396 0



O&K Antriebstechnik GmbH

Ruhrallee 8-12 - 45525 Hattingen
Tel. +49 0 2324 2050 1



India

Bonfiglioli Transmission Pvt. Ltd.
Mobility & Wind Industries
AC 7 - AC 11 Sidco Industrial Estate
Thirumudivakkam Chennai - 600 044
Tel. +91 844 844 8649



Discrete Manufacturing & Process Industries - Motion & Robotics

Survey No. 528/1
Perambakkam High Road Mannur Village,
Sriperumbudur Taluk Chennai - 602 105
Tel. +91 844 844 8649



Discrete Manufacturing & Process Industries

Plot No.A-9/5, Phase IV MIDC Chakan,
Village Nighoje Pune - 410 501
Tel. +91 844 844 8649



Italy

Bonfiglioli Riduttori S.p.A.
Discrete Manufacturing & Process Industries
Via Cav. Clementino Bonfiglioli, 1
40012 Calderara di Reno
Tel. +39 051 6473111



Mobility & Wind Industries

Via Enrico Mattei, 12 Z.I. Villa Selva
47100 Forlì
Tel. +39 0543 789111



Discrete Manufacturing & Process Industries

Via Sandro Pertini lotto 7b
20080 Carpiano
Tel. +39 02985081



Motion & Robotics

Via Unione 49 - 38068 Rovereto
Tel. +39 0464 443435/36



New Zealand

Bonfiglioli Transmission (Aust.) Pty Ltd
88 Hastie Avenue, Mangere Bridge,
2022 Auckland
PO Box 11795, Ellerslie
Tel. +64 09 634 6441



Singapore

Bonfiglioli South East Asia Pte Ltd
8 Boon Lay Way, #04-09,
8@ Tadehub 21, Singapore 609964
Tel. +65 6268 9869



Slovakia

Bonfiglioli Slovakia s.r.o.
Robotnícka 2129
Považská Bystrica, 01701 Slovakia
Tel. +421 42 430 75 64



South Africa

Bonfiglioli South Africa Pty Ltd.
55 Galaxy Avenue, Linbro Business Park,
Sandton, Johannesburg
2090 South Africa
Tel. +27 11 608 2030



Spain

Tecnotrans Bonfiglioli S.A
Pol. Ind. Zona Franca, Sector C,
Calle F, nº 6 - 08040 Barcelona
Tel. +34 93 447 84 00



Turkey

Bonfiglioli Turkey Jsc
Atatürk Organize Sanayi Bölgesi,
10007 Sk. No. 30
Atatürk Organize Sanayi Bölgesi,
35620 Çiğli - İzmir
Tel. +90 0 232 328 22 77



United Kingdom

Bonfiglioli UK Ltd.
Unit 1 Calver Quay, Calver Road, Winwick
Warrington, Cheshire - WA2 8UD
Tel. +44 1925 852667



USA

Bonfiglioli USA Inc.
3541 Hargrave Drive
Hebron, Kentucky 41048
Tel. +1 859 334 3333



Vietnam

Bonfiglioli Vietnam Ltd.
Lot C-9D-CN My Phuoc Industrial Park 3
Ben Cat - Binh Duong Province
Tel. +84 650 3577411



 PRODUCTION

 ASSEMBLY

 SALES

 SERVICE



We have a relentless commitment to excellence, innovation & sustainability. Our team creates, distributes and services world-class power transmission & drive solutions to keep the world in motion.

HEADQUARTERS

Bonfiglioli S.p.A

Registered office: Via Cav. Clementino Bonfiglioli, 1
40012 Calderara di Reno - Bologna (Italy)

Tel. +39 051 6473111

Head office: Via Isonzo, 65/67/69

40033 Casalecchio di Reno - Bologna (Italy)

