



SOLUTIONS FOR

Logistics &  
Intralogistics





*We engineer dreams*



# Contents

---

<b>LOGISTICS &amp; INTRALOGISTICS</b> .....	<b>5</b>
<b>WAREHOUSE &amp; MATERIAL HANDLING</b> .....	<b>6</b>
Roller conveyors .....	8
Belt conveyors .....	9
Automatic storage .....	10
Forklifts.....	11
Warehousing trucks.....	12
Automatic guided vehicles .....	13
<b>AIRPORT EQUIPMENT</b> .....	<b>14</b>
Tow tractors.....	16
Baggage claim conveyors .....	18
<b>POSTEL &amp; PARCEL EQUIPMENT</b> .....	<b>20</b>
Postal handling Solutions .....	22
<b>ACCESS &amp; AERIAL PLATFORMS</b> .....	<b>24</b>
<b>CONVEYING</b> .....	<b>26</b>
Roller conveyors .....	28
Belt conveyors .....	29
Chain conveyors.....	30
Spiral conveyors.....	31
<b>LOGISTICS &amp; INDUSTRIAL CRANES</b> .....	<b>32</b>
Overhead cranes .....	34
Jib cranes .....	36
<b>OUR GLOBAL PRESENCE</b> .....	<b>38</b>

# Engineering Solutions



[WWW.BONFIGLIOLI.COM](http://WWW.BONFIGLIOLI.COM)

# Logistica e Intralogistica

**WE HAVE THE RIGHT SOLUTIONS FOR ALL YOUR INTRALOGISTICS NEEDS!**

More than ever, logistics & intralogistics are at the heart of today's world. From automatic storage systems to warehouse vehicles, all these machines play a key role in the smooth flow of materials. With years of experience in integrating systems and designing complete solutions for specific applications, Bonfiglioli can supply the right solutions to support its customers' growth in materials, transportation and storage technology. Efficiency, reliability, flexibility, loading capability and environmental compatibility are the pillars of the Bonfiglioli offer!



# SOLUTIONS FOR Logistics & Intralogistics

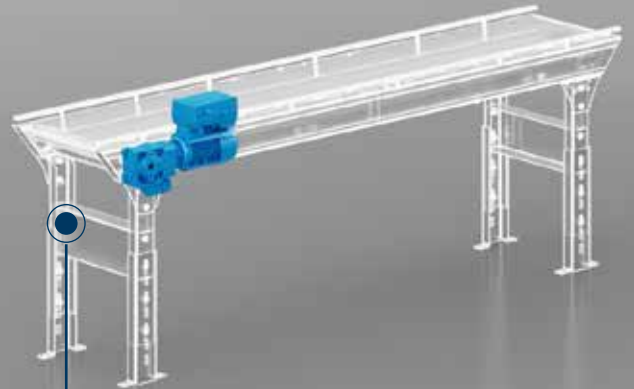
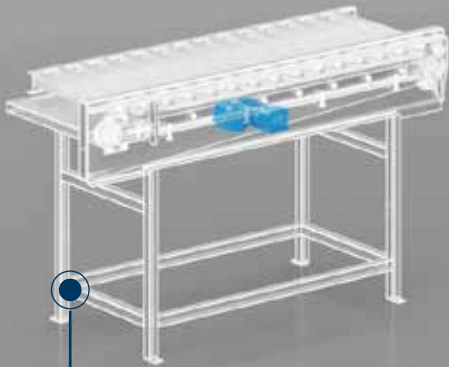
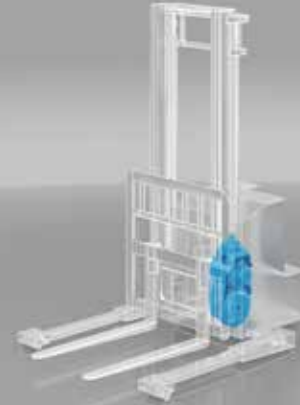

**1** ROLLER CONVEYORS

**2** BELT CONVEYORS

**4** FORKLIFTS

**5** REACH TRUCKS



**6** AMR/AGV

**3** COMPACT AUTOMATIC WAREHOUSE

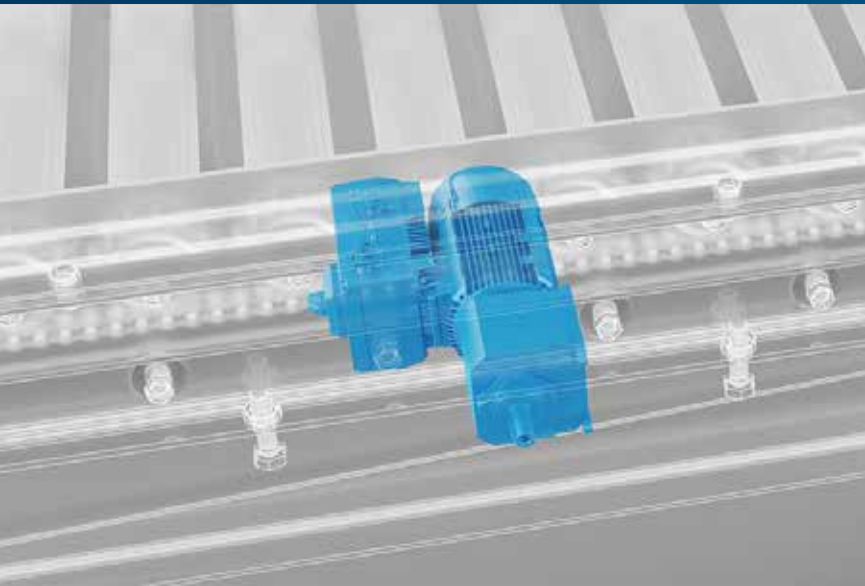

## 1

### ROLLER CONVEYORS

Our solution consists of a complete drive transmission package, from the gearbox to the decentralized inverter. In roller conveyors, our range is based on coaxial gearbox or orthogonal gearboxes with bevel gear, always combined with our compact IE3 electric motor and the IP65 DGM-MPM inverter.



**EVOX CP Series**  
Helical In-Line Gearbox



**EVOX MXN Series**  
Asynchronous Motors



**DGM-MPM Series**  
Decentralized Inverter

#### BENEFITS

- Compact design for high torque density and maximum power
- Low warehousing cost, thanks to the distinctive universal mounting
- Safe operation in potentially explosive atmospheres
- Overall dimension in line with market standards
- Easy-Clean shape

- One motor for different markets
- Simplify installation complexities and inventory management
- Uncompromised Efficiency
- Modular electric motor

- Wide range of kW from 0.55 to 30kW
- Ethernet stack to manage with 1 product code: Profinet, Ethernet IP, Sercos3, Ethercat
- Motor brake management

#### FEATURES

- Lifetime lubricated
- Unique oil level for all mounting position
- Stainless steel shaft and plug option
- Reinforced bearings option

- IE3 Efficiency level
- Power range up to 7,5kW
- Built in DC brake
- Thermal protection
- Anti-condensate heaters
- Second shaft extension
- Anti corrosive painting up to C5M
- Tropicalization
- Degree of protection up to IP56

- IP65 Inverter
- Reduction of electrical wiring
- Management of asynchronous induction, synchronous reluctance and permanent magnet motors

## 2

### BELT CONVEYORS

Our solution consists of a complete drive transmission package, from the gearbox to the decentralized inverter. In roller conveyors, our solution is based on coaxial gearbox or orthogonal gearboxes with bevel gear, always combined with our compact IE3 electric motor and the IP65 DGM-MPM inverter.

In applications where high efficiency is required, we can offer our synchronous reluctance motor with IE4 efficiency.



**A Series**  
Helical Bevel Gearbox



**BSR Series**  
Synchronous Reluctance Motors



**DGM-MPM Series**  
Decentralized Inverter

#### BENEFITS

- Reduced installation space
- Wide output speed range
- High stiffness for dynamic application
- Safe operation in potentially explosive atmospheres

- No need for feedback device for positioning
- One or two sizes less compared to standard asynchronous motors
- Minimal maintenance required
- Sustainable solution
- Excellent performance and dynamics

- Wide range of kW from 0.55 to 30kW
- Ethernet stack to manage with 1 product code: Profinet, Ethernet IP, Sercos3, Ethercat
- Motor brake management

#### FEATURES

- Shaft mounting with hollow shaft and torque arm or shrink disk
- Reinforced bearings available as an option
- Reduced backlash as an option

- Motor efficiency class up to IE4
- Power range: up to 18,5 kW
- Wide range of options

- IP65 Inverter
- Reduction of electrical wiring
- Management of asynchronous induction, synchronous reluctance and permanent magnet motors

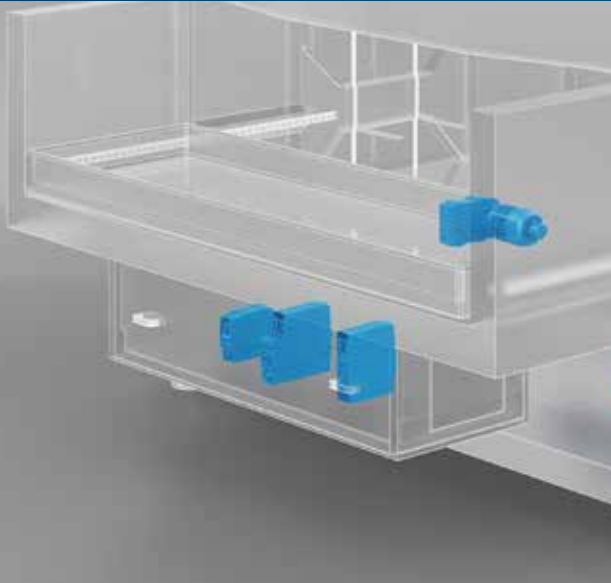

3

## COMPACT AUTOMATIC WAREHOUSE

We supply our customers with complete solutions that guarantee the highest possible precision, efficiency and energy optimization for automatic storage applications. From the inverter to the drives, Bonfiglioli is a one-stop company that understands and able to face today's market challenges.



### F Series Shaft Mounted Gearbox

#### BENEFITS

- High efficiency
- Reliability and robustness
- Compactness
- Low maintenance



### EVOX BXN Series Asynchronous Induction Phase Motor

- One motor for different markets
- Simplify installation complexities and inventory management
- Uncompromised Efficiency
- Modular electric motor



### AxiaVert Series High Performance Cabinet Inverter

- Modular system
- Wide power range
- Versatile Communication
- High mounting flexibility

#### FEATURES

- Power range: up to 55 kW
- Shaft mounted solution with different output configurations
- Housing integrated torque arm design and anti-vibration kits
- Wide range of ratios
- Space-saving compact motor design
- Availability of different grade of protection
- Compact or IEC/NEMA flanged motor adaptors

- IE3 Efficiency level
- Power range up to 7,5kW
- Built in DC brake
- Thermal protection
- Anti-condensate heaters
- Second shaft extension
- Anti corrosive painting up to C5M
- Tropicalization
- Degree of protection up to IP56

- Selectable Functional safety features (up to SIL 3 / PL e / CAT. 4)
- Wide range of Encoder supports for various systems
- Customizable logic functions with internal optional PLC (IEC61131)
- Integrated PID control system
- Various Control modes incl. Position, Speed or Torque Control & CiA402-compatible Motion Control
- Easy wiring with detachable signal and power terminals (up to 15 kW)

## 4

### FORKLIFTS

Bonfiglioli supplies high-efficiency, low-noise planetary axles and drives with integrated high performance electric motors and low maintenance braking systems for Class 1 material handling vehicles. Typical applications include 3- and 4-wheel counterbalance lift trucks and ground support equipment. Bonfiglioli electric powertrains are fully tested in the factory and guarantee low energy consumption. This, in turn, means longer battery operating times, extended servicing intervals and lower costs of ownership.

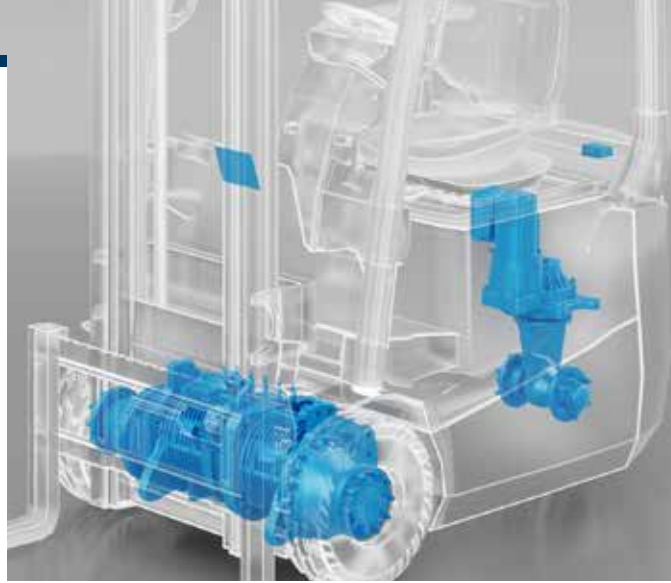

#### 600F Series Traction Systems

- Maximum efficiency
- Minimum noise
- Complete solution
- Fully tested



#### 600W0C Series Idle Steering System

- 360° steering
- Complete solution
- Fully tested



#### DISPLAY Customized solution

- High integration level
- High-end & high-speed design
- All black IPS display
- Polyphonic grade alarms
- Double high-speed (and full management) of can interface
- IP65 grade protection
- Capacitive touch button
- Light sensor for backlight



#### DC/DC CONVERTER Customized solution

- Extended input voltage
- Back and forward topology
- Multiple output power version with the same enclosure
- Isolated and not isolated topology
- Thermal protection
- Output protection
- Balancing power between 2 DC/DC
- LIN interface
- Input enable
- Up to 60°C ambient temperature
- IP65 grade protection

BENEFITS

FEATURES

TECHNICAL DATA

	Axle torque (Nm)
601 F	3,000
602 F	5,500
603 F	7,000
605 F	18,000
610 F	50,000

	Lift capacity (kg)
601 F	2,000
602 F	3,500
603 F	5,000
605 F	9,000
610 F	16,000

	Lift capacity (kg)
601 W0C	2,000
602 W0C	3,000
603 W0C	3,500

## 5

### WAREHOUSING TRUCKS

Bonfiglioli EL powertrains are a perfect match for the most demanding warehousing applications (Class 2 and Class 3). Warehousing trucks require high maneuverability in tight spaces, provided by drives like those in the EL series, with the smallest operating radius in vertical arrangements.

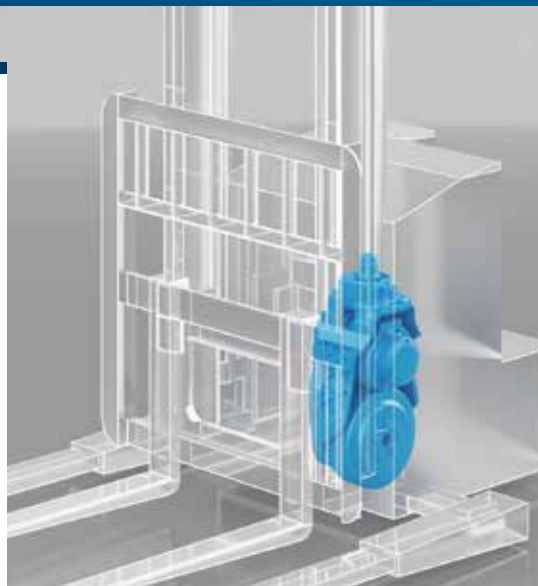

### EL Series Steerable Drives

#### BENEFITS

- Maximum efficiency
- Minimum noise
- Complete solution
- Fully tested

#### FEATURES

- Two-stage helical & bevel gearboxes
- Manual steering and power steering versions
- Optimized gear design for efficiency and noise
- Integrated low-voltage electric motor
- Integrated parking brake
- Complete system with tires

#### TECHNICAL DATA

	Torque (Nm)	Max wheel load (kg)
EL100	450	1,200
EL09	500	1,200
EL96	500	1,500
EL10	900	1,500
EL300	1,100	2,200
EL92	1,500	3,000
EL93	1,500	3,000
EL94	1,500	3,000
EL14	1,900	3,400
EL16	2,500	4,000

## 6

### AUTOMATIC GUIDED VEHICLES

Automatic Guided Vehicles (AGVs) and Autonomous Mobile Robots (AMRs) are a range of driverless transportation robots that can autonomously transport materials through designated pickup and delivery routes within a facility. AGVs and AMRs are easy to integrate into existing processes, simplifying intralogistic flows and increasing automation levels. Due to this, a wide range of sectors is adopting these solutions.

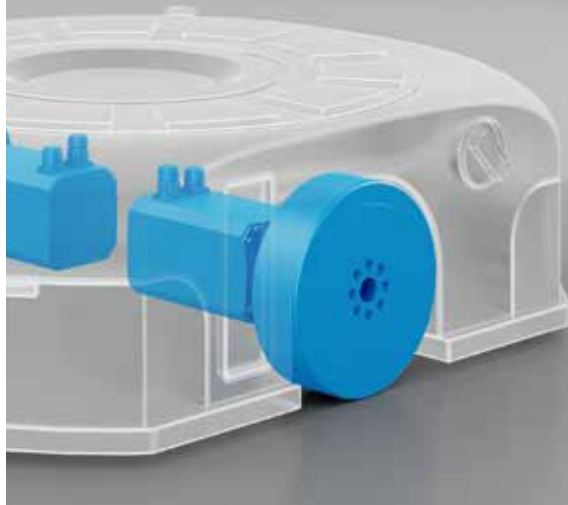

#### BlueRoll Basic

TQW: the new Wheel-Mounted Gearbox Series

- Easy installation
- Heavy load capability
- Great reliability
- Minimized installation space



#### BlueRoll Advanced

Powerful and Compact Servo Gearmotors

- High energy efficiency
- Stiff and precise
- High torque capability
- High flexibility



#### BlueRoll Compact

Extra Compact Servo Gearmotors

- Simplified AGV design
- Suitable for long operation
- Top level configuration

#### BENEFITS

#### FEATURES

- Three gearmotor sizes, rated for loads up to: 360kg, 720kg and 1020kg
- Speed up to 2 m/s
- New wheel-mounted precision planetary gearbox: TQW
- Permanent Magnet Synchronous Motors with premium efficiency
- Wide range of feedback systems, including safety encoders
- Compact design, extensively customizable

#### TECHNICAL DATA

	Torque (Nm)
TQW 060	30
TQW 070	65
TQW 090	155



## **2** BAGGAGE CLAIM CONVEYORS

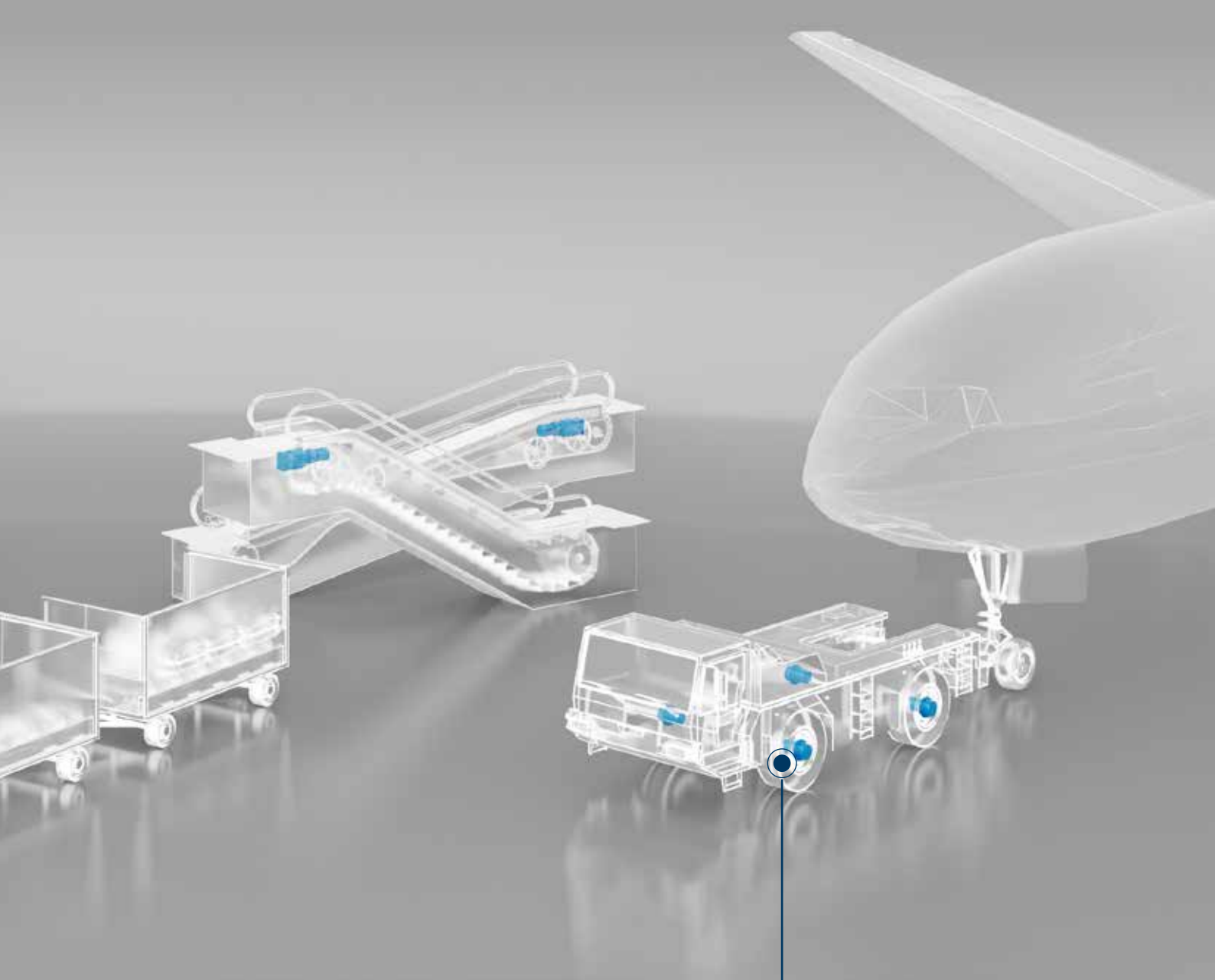

**1** TOW TRACTORS

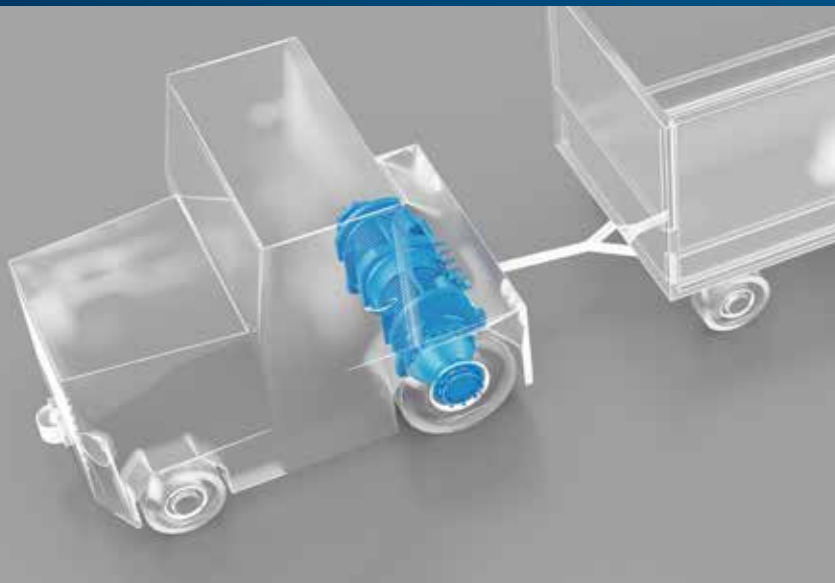

1

## TOW TRACTORS

Bonfiglioli supplies high efficiency, low noise axles with integrated, high performance electric motors and low maintenance braking systems for ground support equipment (Industrial Trucks Class VI, electric type) and other electric material handling machinery used at airports. Bonfiglioli electric axles are fully tested in the factory. All drives guarantee reduced energy consumption, this means longer battery operating times, extended service intervals and a lower total cost of ownership.



## 600F Series TractionSystems

### BENEFITS

- Maximum efficiency
- Minimum noise
- Complete solution
- Fully tested

### FEATURES

- Dual stage gearbox
- Optimized gear design
- Service brake
- Parking brake
- Integrated, customized mast support
- Integrated AC traction motor protection rating up to IP54
- Integrated, high accuracy, silicon-based KTY temperature sensor
- Integrated, high resolution hall effect speed sensor

### TECHNICAL DATA

	Torque (Nm)	Max draw bar pull force (kN)
600 D	1,000	5 ... 8
601 F	3,000	9 ... 14
602 F	5,500	15 ... 18
603 F	7,000	20 ... 30

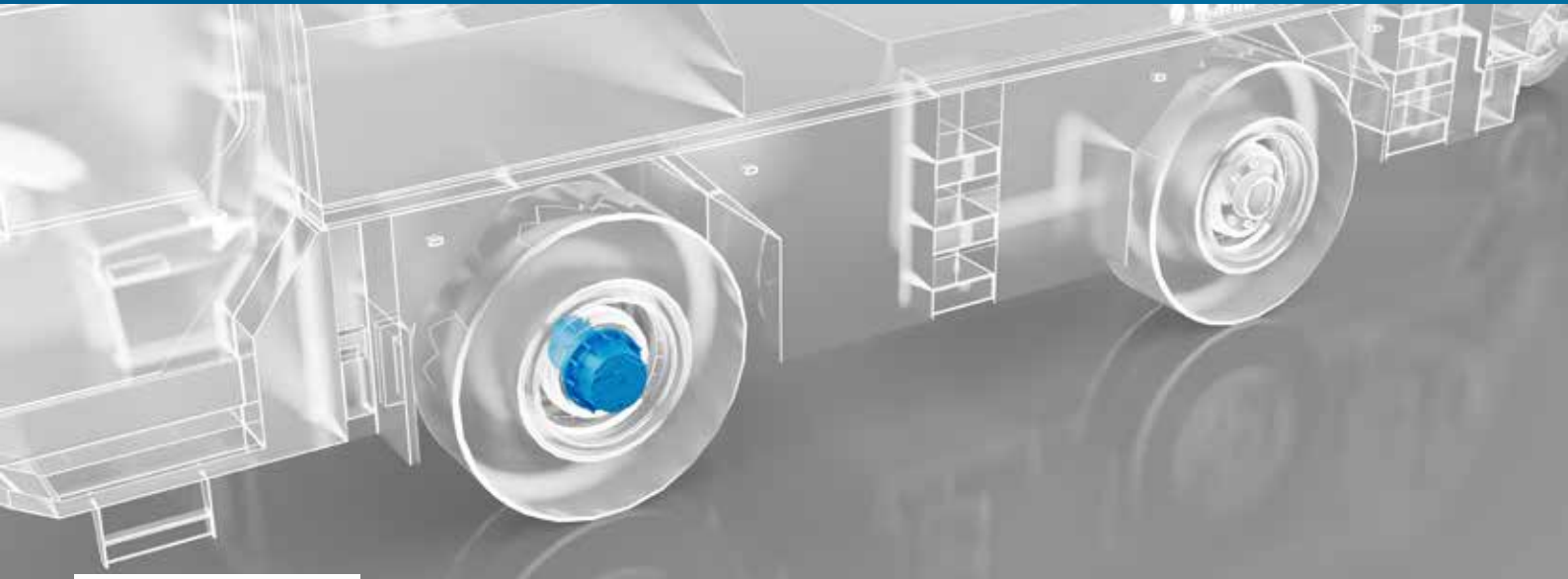

## 600W Series Wheel Drives

### BENEFITS

#### Benefits for OEMs

- Ability to downsize and downspeed combustion engines
- Easy installation: electric solution dimensions comparable to standard hydrostatics
- Higher system reliability: fewer mechanical parts
- Virtually maintenance-free electric motors
- From wheel bolt to electric wire with only one supplier

#### Benefits for end users

- Reduced fuel consumption
- Increased productivity
- Better machine manoeuvrability
- The electric solution is cleaner: lower risk of oil spills

### FEATURES

- Multi-stage planetary gearbox
- Rotating housing output
- Validated in the field

- Permanent magnet motors
- Suitable for batteries 400 - 700Vdc
- Liquid cooled
- Aluminium or cast iron housing
- Protection rating >IP54

### TECHNICAL DATA

	Torque (Nm)
605 W..V..	10,000
606 W..V	17,000
607 W..V	22,000
609 W..V	30,000
610 W..V	36,000
610 X	40,000
611 W..V	45,000
613 W..V	60,000

	Rated power (kW)
BPM 240-L1	20
BPM 240-L2	35
BPM 240-L3	65
BPM 300-L1	100
BPM 300-L2	150

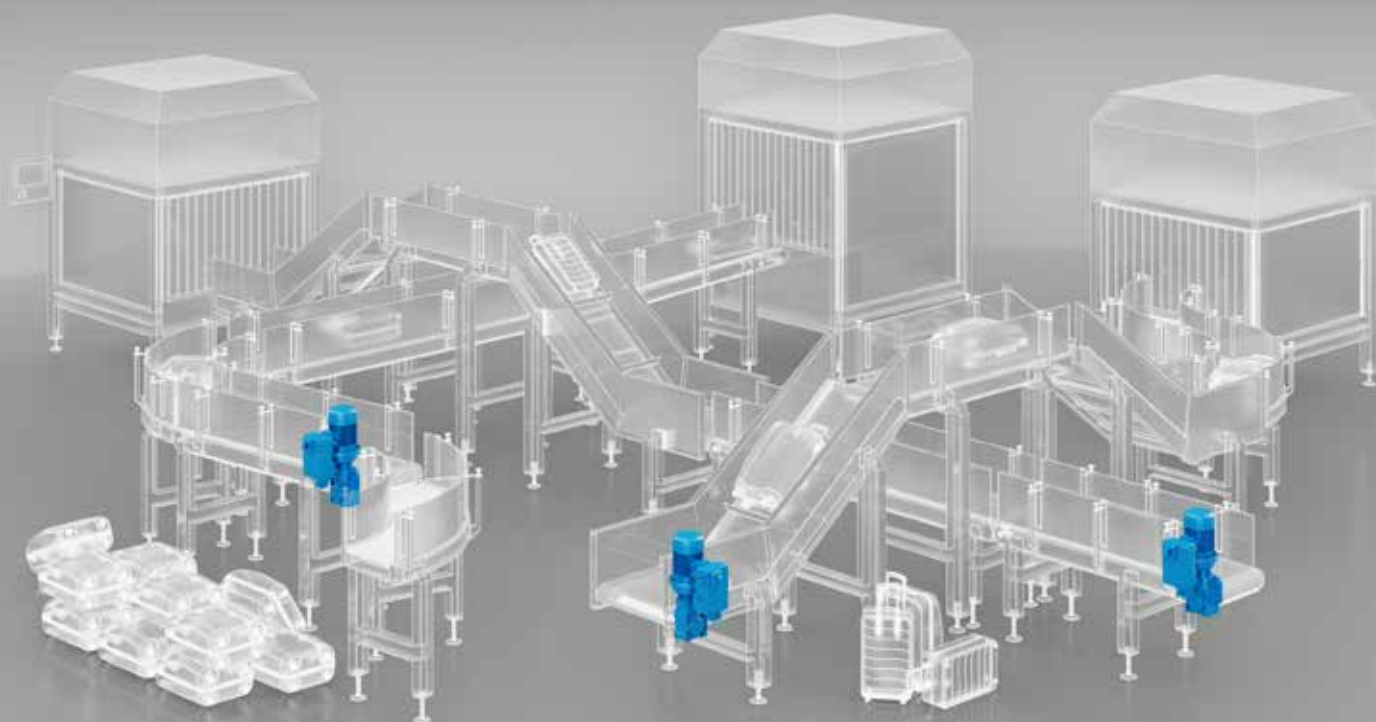

## 2

### BAGGAGE CLAIM CONVEYORS

Our solution provides a complete drive transmission package, from the gearbox to the inverter.

For baggage claim conveyors, our range is based on bevel gearboxes, always in combination with our IE3 electric motor and decentralized inverters.

In this kind of applications where high efficiency is required, we can offer our synchronous reluctance motor with IE4 efficiency.



**A Series**  
Helical Bevel Gearbox

**BENEFITS**

- Reduced installation space
- Wide output speed range
- High stiffness for dynamic application
- Safe operation in potentially explosive atmospheres

**FEATURES**

- Shaft mounting with hollow shaft and torque arm or shrink disk
- Reinforced bearings available as an option
- Reduced backlash as an option



**BSR Series**  
Synchronous Reluctance Motors

- No need for feedback device for positioning
- One or two sizes less compared to standard asynchronous motors
- Minimal maintenance required
- Sustainable solution
- Excellent performance and dynamics

- Motor efficiency class up to IE4
- Power range: up to 18,5 kW
- Wide range of options



**DGM-MPM Series**  
Decentralized Inverter

- Wide range of kW from 0.55 to 30kW
- Ethernet stack to manage with 1 product code: Profinet, Ethernet IP, Sercos3, Ethercat
- Motor brake management

- IP65 Inverter
- Reduction of electrical wiring
- Management of asynchronous induction, synchronous reluctance and permanent magnet motors

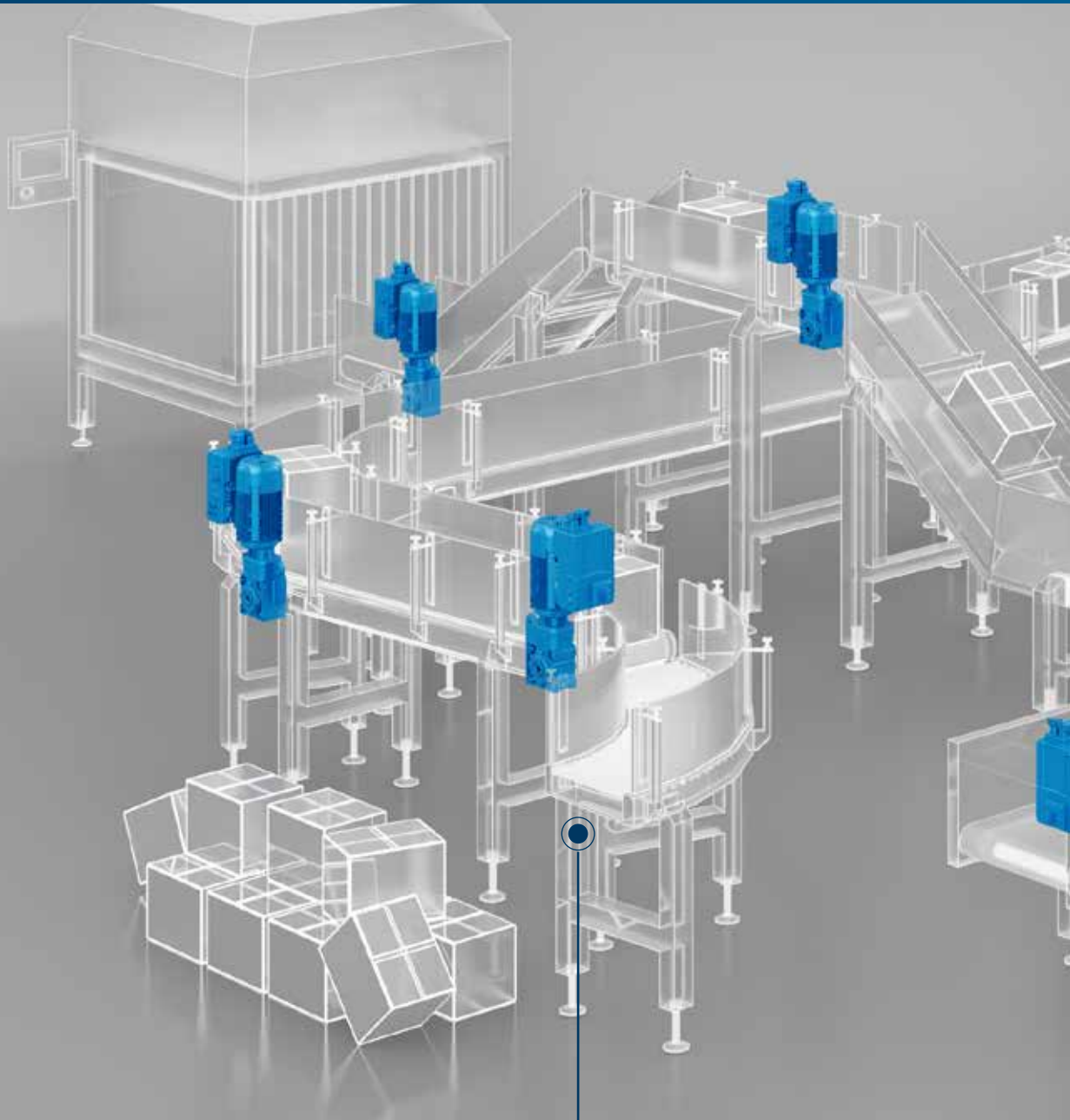

**1** POSTAL HANDLING  
SOLUTIONS

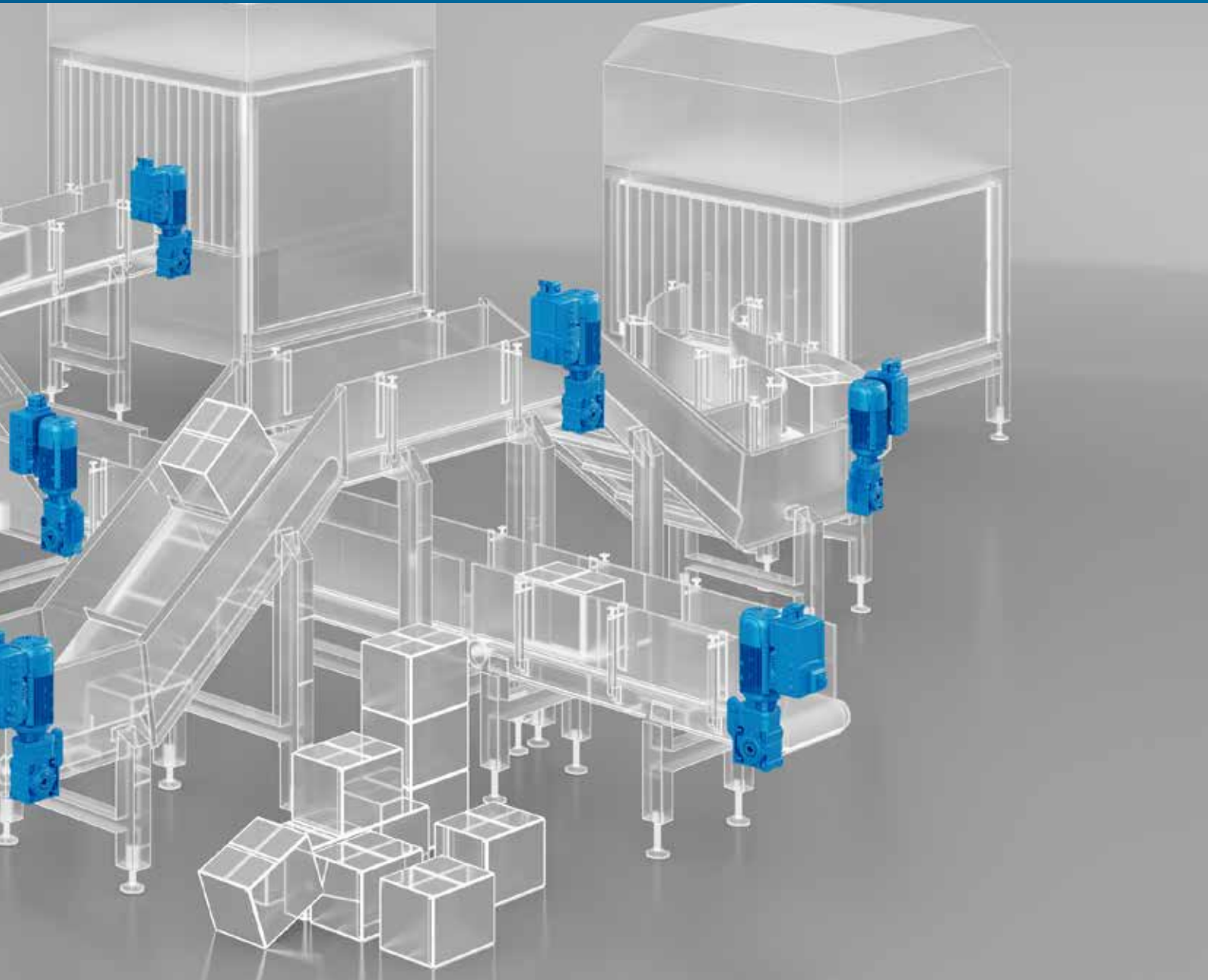

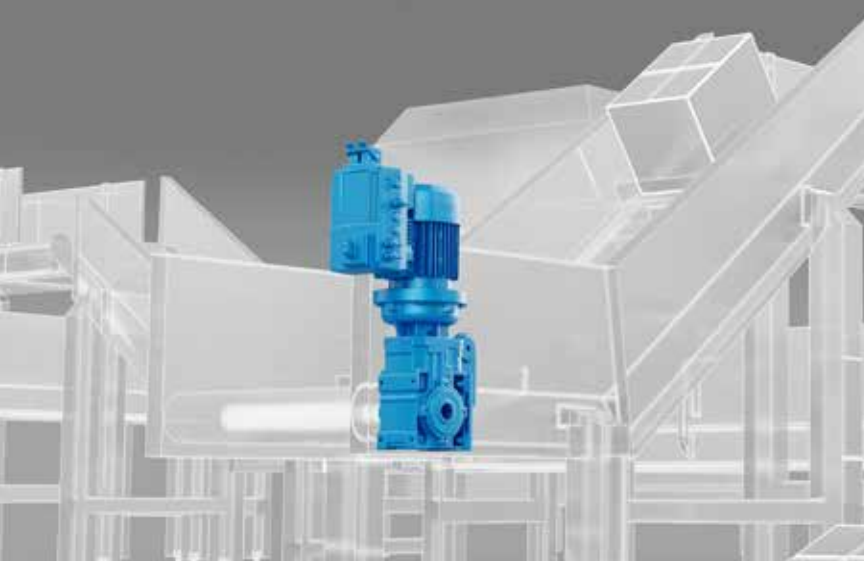

1

## POSTAL HANDLING SOLUTIONS

Our solution provides a complete drive transmission package, from the gearbox to the inverter. For baggage claim conveyors, our range is based on bevel gearboxes, always in combination with our IE3 electric motor and decentralized inverters. In this kind of applications where high efficiency is required, we can offer our synchronous reluctance motor with IE4 efficiency.



**A Series**  
Helical Bevel Gearbox



**BSR Series**  
Synchronous Reluctance  
Motors



**DGM-MPM Series**  
Decentralized Inverter

### BENEFITS

- Reduced installation space
- Wide output speed range
- High stiffness for dynamic application
- Safe operation in potentially explosive atmospheres

- No need for feedback device for positioning
- One or two sizes less compared to standard asynchronous motors
- Minimal maintenance required
- Sustainable solution
- Excellent performance and dynamics

- Wide range of kW from 0.55 to 30kW
- Ethernet stack to manage with 1 product code: Profinet, Ethernet IP, Sercos3, Ethercat
- Motor brake management

### FEATURES

- Shaft mounting with hollow shaft and torque arm or shrink disk
- Reinforced bearings available as an option
- Reduced backlash as an option

- Motor efficiency class up to IE4
- Power range: up to 18,5 kW
- Wide range of options

- IP65 Inverter
- Reduction of electrical wiring
- Management of asynchronous induction, synchronous reluctance and permanent magnet motors

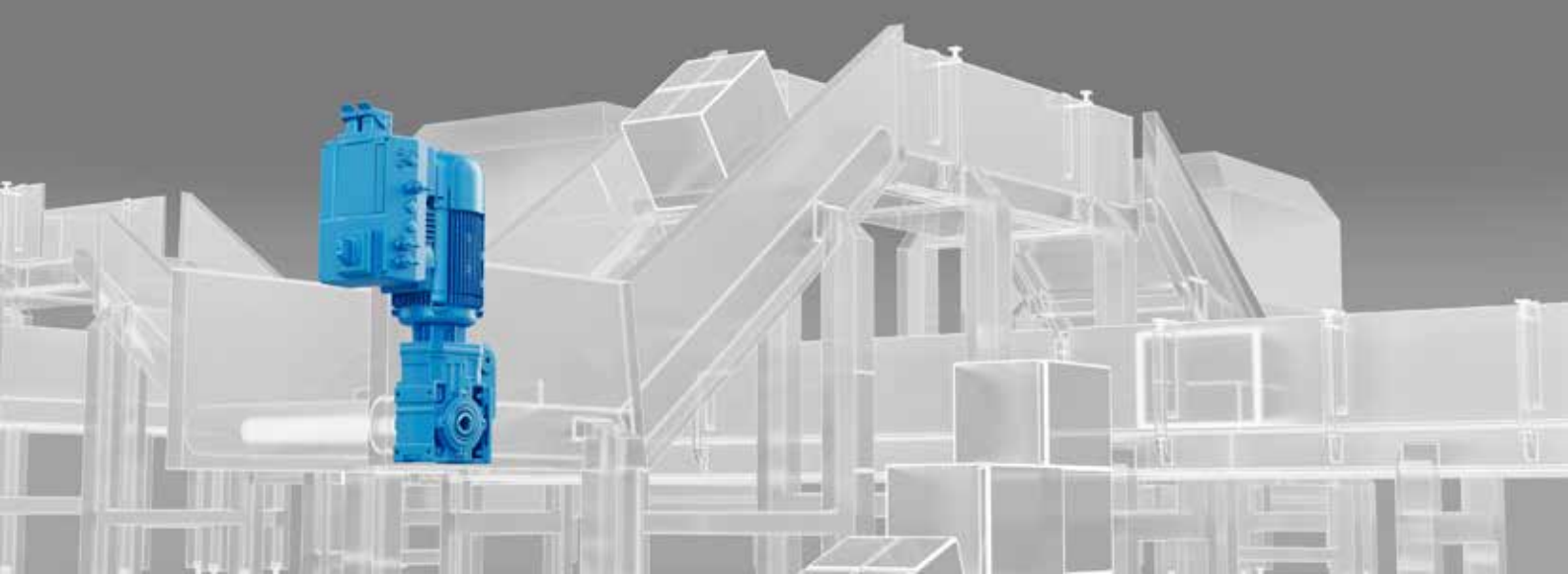

**A Series**  
Helical Bevel Gearbox

**BENEFITS**

- Reduced installation space
- Wide output speed range
- High stiffness for dynamic application
- Safe operation in potentially explosive atmospheres



**EVOX BXN Series**  
Asynchronous Induction  
Phase Motor

**FEATURES**

- Shaft mounting with hollow shaft and torque arm or shrink disk
- Reinforced bearings available as an option
- Reduced backlash as an option

- One motor for different markets
- Simplify installation complexities and inventory management
- Uncompromised Efficiency
- Modular electric motor

- IE3 Efficiency level
- Power range up to 7,5kW
- Built in DC brake
- Thermal protection
- Anti-condensate heaters
- Second shaft extension
- Anti corrosive painting up to C5M
- Tropicalization
- Degree of protection up to IP56



**DGM-MPM Series**  
Decentralized Inverter

- Wide range of kW from 0.55 to 30kW
- Ethernet stack to manage with 1 product code: Profinet, Ethernet IP, Sercos3, Ethercat
- Motor brake management

- IP65 Inverter
- Reduction of electrical wiring
- Management of asynchronous induction, synchronous reluctance and permanent magnet motors

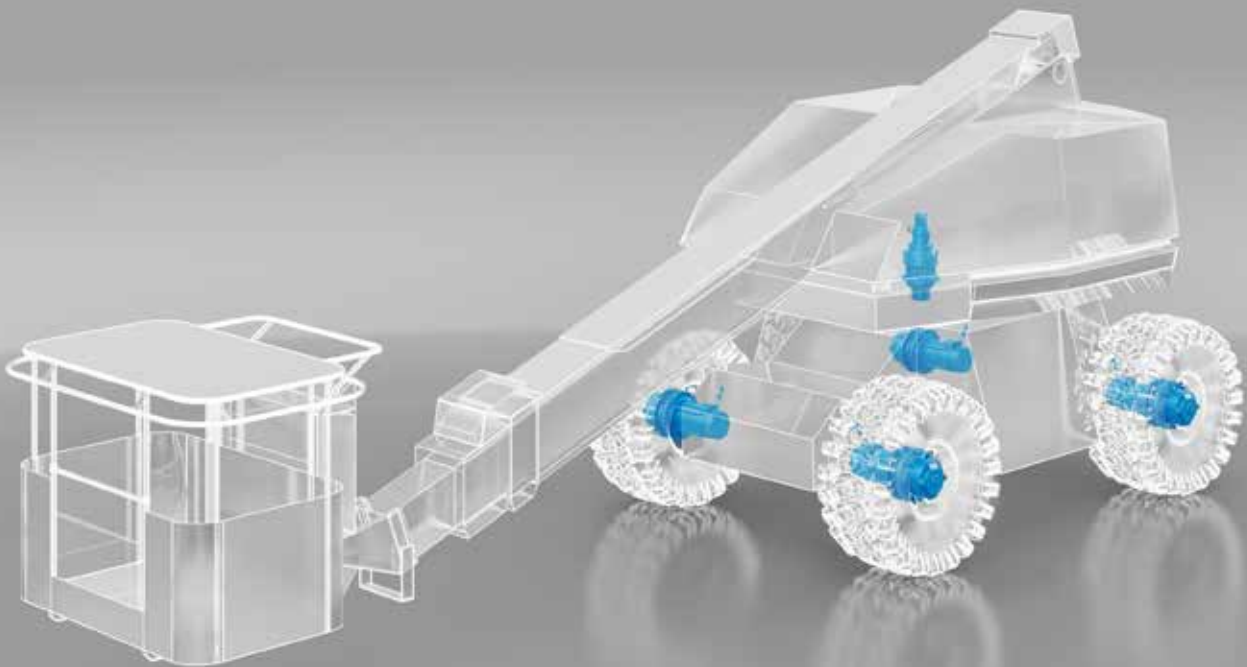

## ACCESS PLATFORMS

### Wheel drives

With a reliable series of products made for access platforms, Bonfiglioli gives machine builders the best possible choice of drive systems. The compact, silent, highly efficient and maintenance-free integrated drive motors are excellent with access platforms for indoor and outdoor use.

### Slew drives

Bonfiglioli slew drives are the most effective solution for both hydraulic and electric access platforms.

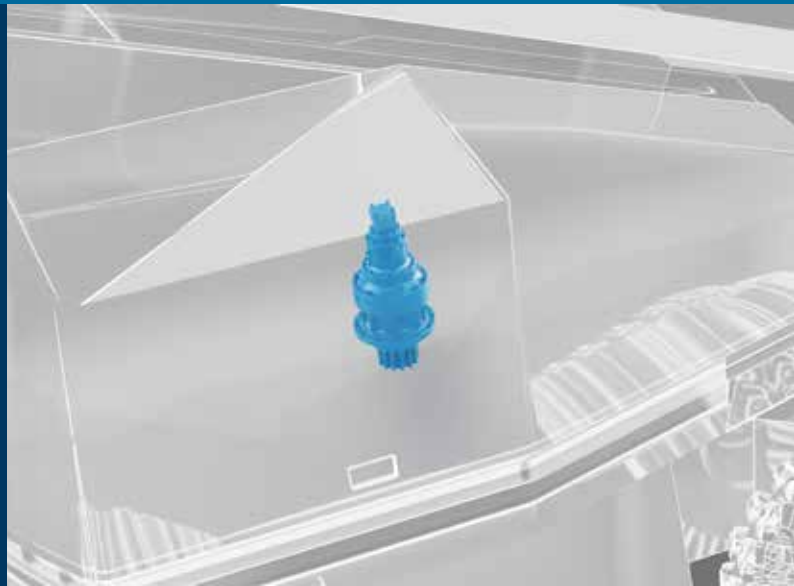
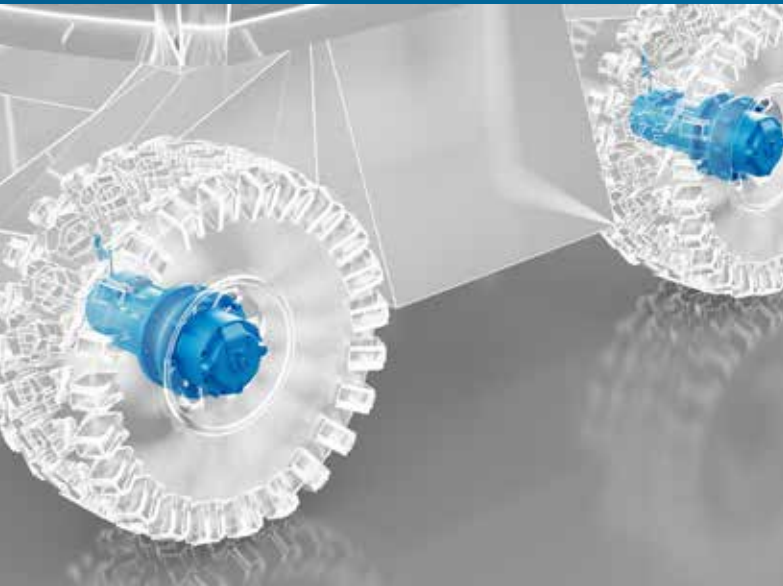

**600WE Series**  
Wheel Drives



**700T Series**  
Slew Drives

## BENEFITS

- Compact dimensions
- Low noise
- High efficiency
- Maintenance-free motors

- Rugged construction
- Flange mounted
- High torque capacity

## FEATURES

- Two- or three-stage planetary drive with reduction ratios of up to 1:145
- Optimized gear design for maximum efficiency and minimum noise
- Integrated, low voltage, 3-phase induction motor
- Integrated, high accuracy, temperature sensor
- High resolution, hall-effect speed sensor
- Motor protection rating up to IP67

- Driven by hydraulic or electric motor
- Output shaft with pinion
- Compact design
- Wide range of pinions
- Including brake, wet disc or electromagnetic

## TECHNICAL DATA

	Torque (Nm)
600 WL	500
600 WE	900
601 RE	3,000
602 RE	3,500
602 WE	4,500
604 WE	7,000
605 WE	10,000

	Torque (Nm)
700 T F	1,200
701 T F	2,400
703 T F	3,500
705 T F	6,500

# SOLUTIONS FOR Logistics & Intralogistics

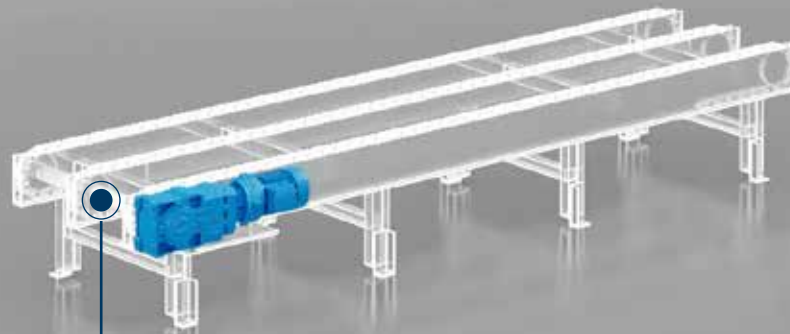
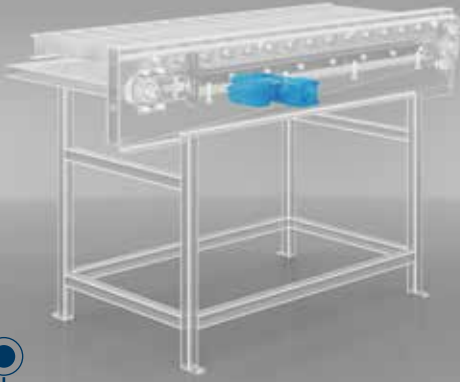

**1** ROLLER CONVEYORS

**3** CHAIN CONVEYORS

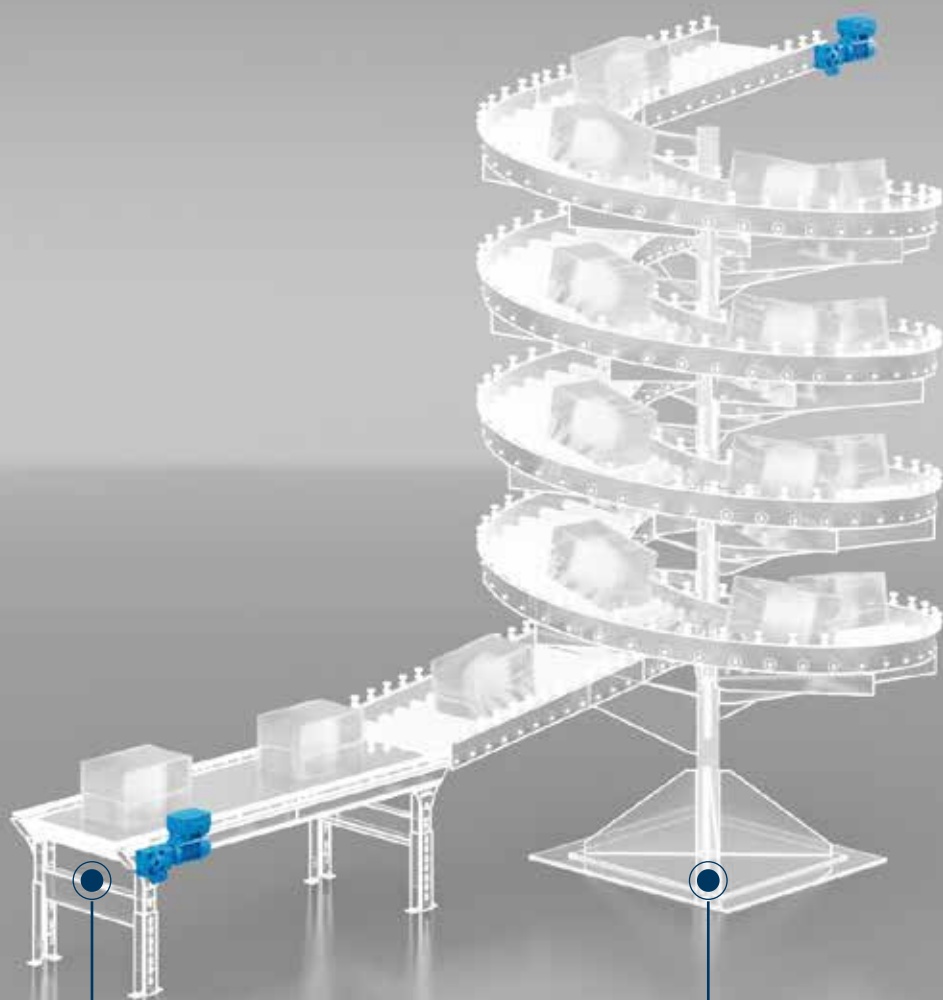

**2** BELT CONVEYORS

**4** SPIRAL CONVEYORS

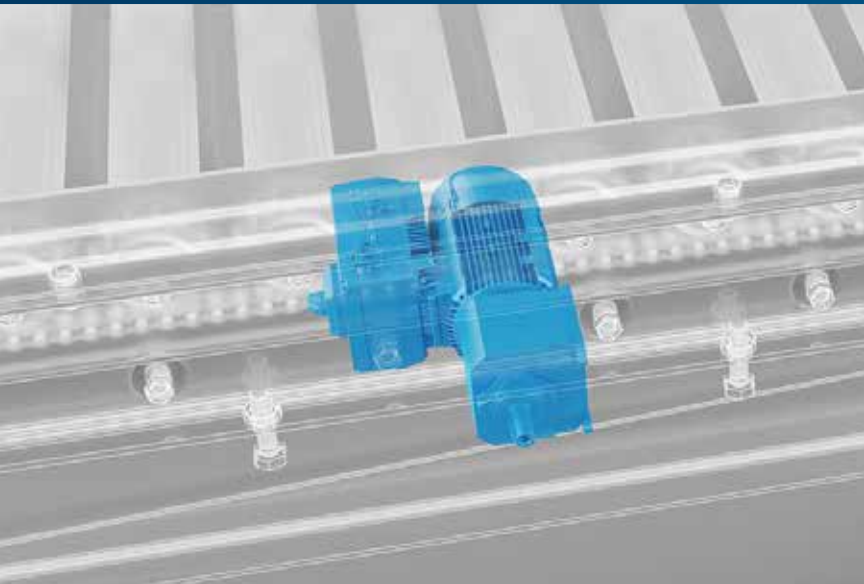

1

## ROLLER CONVEYORS

Bonfiglioli provides a complete drive transmission package, from the gearbox to the decentralized inverter. In roller conveyors, our solution is based on coaxial gearbox or orthogonal gearboxes with bevel gear, always combined with our compact IE3 electric motor and the IP65 DGM-MPM inverter.



**EVOX CP Series**  
Helical In-Line Gearbox



**EVOX MXN Series**  
Asynchronous Motors



**DGM-MPM Series**  
Decentralized Inverter

### BENEFITS

- Compact design for high torque density and maximum power
- Low warehousing cost, thanks to the distinctive universal mounting
- Safe operation in potentially explosive atmospheres
- Overall dimension in line with market standards
- Easy-Clean shape

- One motor for different markets
- Simplify installation complexities and inventory management
- Uncompromised Efficiency
- Modular electric motor

- Wide range of kW from 0.55 to 30kW
- Ethernet stack to manage with 1 product code: Profinet, Ethernet IP, Sercos3, Ethercat
- Motor brake management

### FEATURES

- Lifetime lubricated
- Unique oil level for all mounting position
- Stainless steel shaft and plug option
- Reinforced bearings option

- IE3 Efficiency level
- Power range up to 7,5kW
- Built in DC brake
- Thermal protection
- Anti-condensate heaters
- Second shaft extension
- Anti corrosive painting up to C5M
- Tropicalization
- Degree of protection up to IP56

- IP65 Inverter
- Reduction of electrical wiring
- Management of asynchronous induction, synchronous reluctance and permanent magnet motors

## 2

### BELT CONVEYORS

Bonfiglioli provides a complete drive transmission package, from the gearbox to the decentralized inverter. In roller conveyors, our solution is based on coaxial gearbox or orthogonal gearboxes with bevel gear, always combined with our compact IE3 electric motor and the IP65 DGM-MPM inverter. In applications where high efficiency is required, we can offer our synchronous reluctance motor with IE4 efficiency.

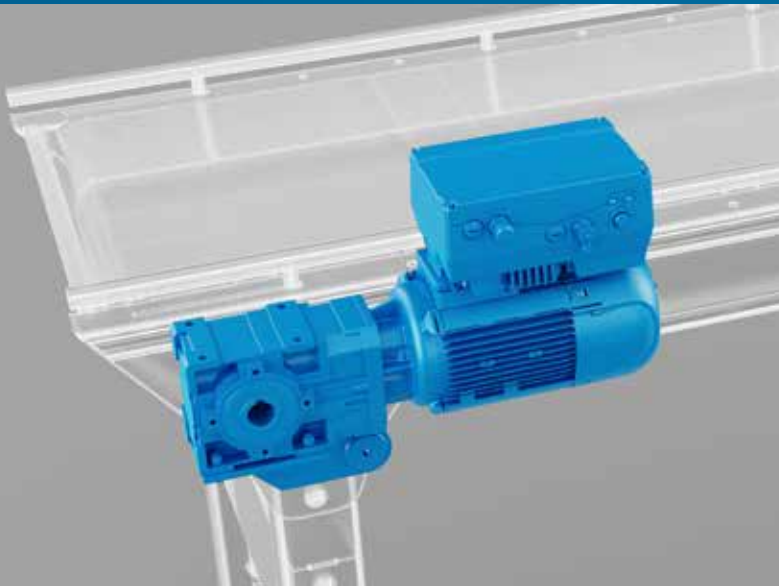

**A Series**  
Helical Bevel Gearbox



**BSR Series**  
Synchronous Reluctance Motors



**DGM-MPM Series**  
Decentralized Inverter

#### BENEFITS

- Reduced installation space
- Wide output speed range
- High stiffness for dynamic application
- Safe operation in potentially explosive atmospheres

- No need for feedback device for positioning
- One or two sizes less compared to standard asynchronous motors
- Minimal maintenance required
- Sustainable solution
- Excellent performance and dynamics

- Wide range of kW from 0.55 to 30kW
- Ethernet stack to manage with 1 product code: Profinet, Ethernet IP, Sercos3, Ethercat
- Motor brake management

#### FEATURES

- Shaft mounting with hollow shaft and torque arm or shrink disk
- Reinforced bearings available as an option
- Reduced backlash as an option

- Motor efficiency class up to IE4
- Power range: up to 18,5 kW
- Wide range of options

- IP65 Inverter
- Reduction of electrical wiring
- Management of asynchronous induction, synchronous reluctance and permanent magnet motors

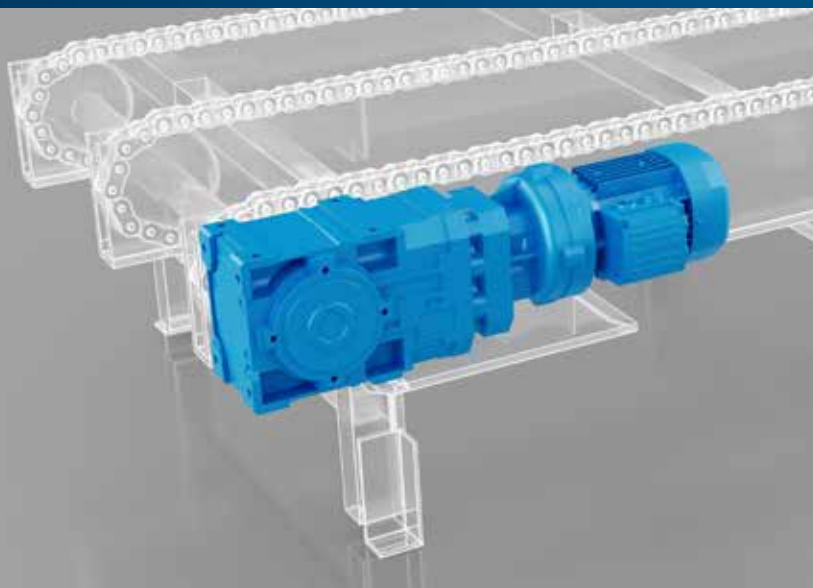

3

## CHAIN CONVEYORS

Chain conveyors are used in many industries to transport all kinds of material: metal, mining, coal, chemical, food, ports and others.

Bonfiglioli knows how to size the correct solution, taking loads and all other specific needs into account.

Our range runs from harsh and explosive atmospheres to food contact environments, offering a wide range of gearmotors and inverters.



**A Series**  
Helical Bevel Gearbox



**MX Series**  
Asynchronous Motors



**Agile Series**  
Smart inverter

### BENEFITS

- Reduced installation space
- Wide output speed range
- High stiffness for dynamic application
- Safe operation in potentially explosive atmospheres

- Reliable, balanced and robust
- Compliant with the most of the efficiency standards

- Smooth start
- Variable "cut position" for smaller particles
- Energy saving function: current consumption redirection during start phase

### FEATURES

- Shaft mounting with hollow shaft and torque arm or shrink disk
- Reinforced bearings available as an option
- Reduced backlash as an option

- Motor efficiency class IE3
- Power range: up to 18,5 kW
- Built in DC brakes
- Wide range of options
- Degree of protection up to IP56

- Series optionally extendable for field bus communication
- Sensorless control of synchronous and asynchronous motors
- Modbus and Systembus onboard
- DC link connection
- Integrated brake chopper
- Power failure control
- Programmable PI Controller
- Integrated VPLC
- Master/slave function with electronic gear
- Integrated safe torque off STO (SIL 2 / PL d) function
- Energy Saving function
- Intelligent current limits
- Output frequency 0...599 Hz, higher frequencies on request
- Diagnosis and setup via integrated keypad and integrated Service interface for PC connection

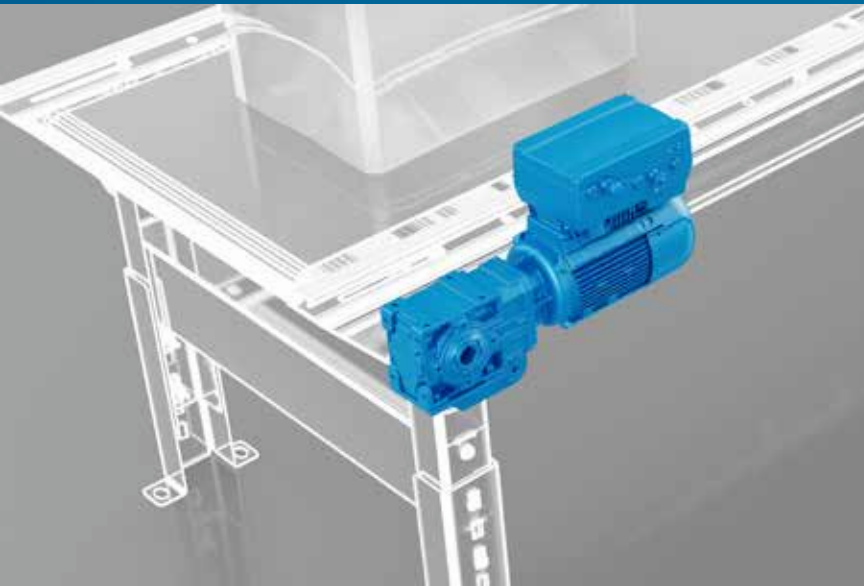

4

**SPIRAL CONVEYORS**

Our solution consists of a complete drive transmission package, from the gearbox to the decentralized inverter. For spiral conveyors, our range is based on bevel gearboxes, always in combination with our IE3 electric motor and our internal panel inverters. In applications where high efficiency is required, we can offer our synchronous reluctance motor with IE4 efficiency



**A Series**  
Helical Bevel Gearbox



**EVOX BXN Series**  
Asynchronous Induction  
Phase Motor



**DGM-MPM Series**  
Decentralized Inverter

**BENEFITS**

- Reduced installation space
- Wide output speed range
- High stiffness for dynamic application
- Safe operation in potentially explosive atmospheres

- One motor for different markets
- Simplify installation complexities and inventory management
- Uncompromised Efficiency
- Modular electric motor

- Wide range of kW from 0.55 to 30kW
- Ethernet stack to manage with 1 product code: Profinet, Ethernet IP, Sercos3, Ethercat
- Motor brake management

**FEATURES**

- Shaft mounting with hollow shaft and torque arm or shrink disk
- Reinforced bearings available as an option
- Reduced backlash as an option

- IE3 Efficiency level
- Power range up to 7,5kW
- Built in DC brake
- Thermal protection
- Anti-condensate heaters
- Second shaft extension
- Anti corrosive painting up to C5M
- Tropicalization
- Degree of protection up to IP56

- IP65 Inverter
- Reduction of electrical wiring
- Management of asynchronous induction, synchronous reluctance and permanent magnet motors

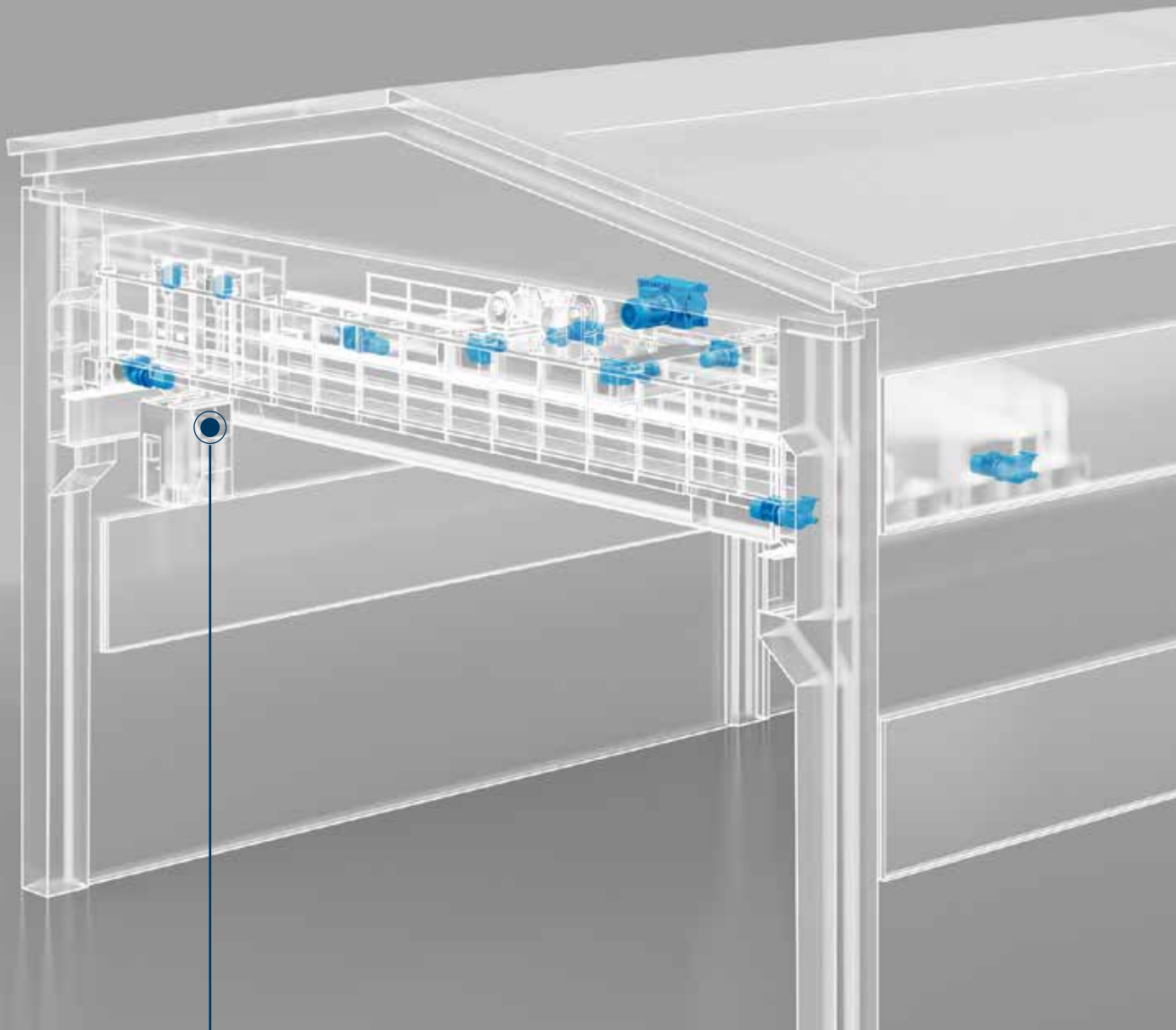

**1** OVERHEAD CRANES

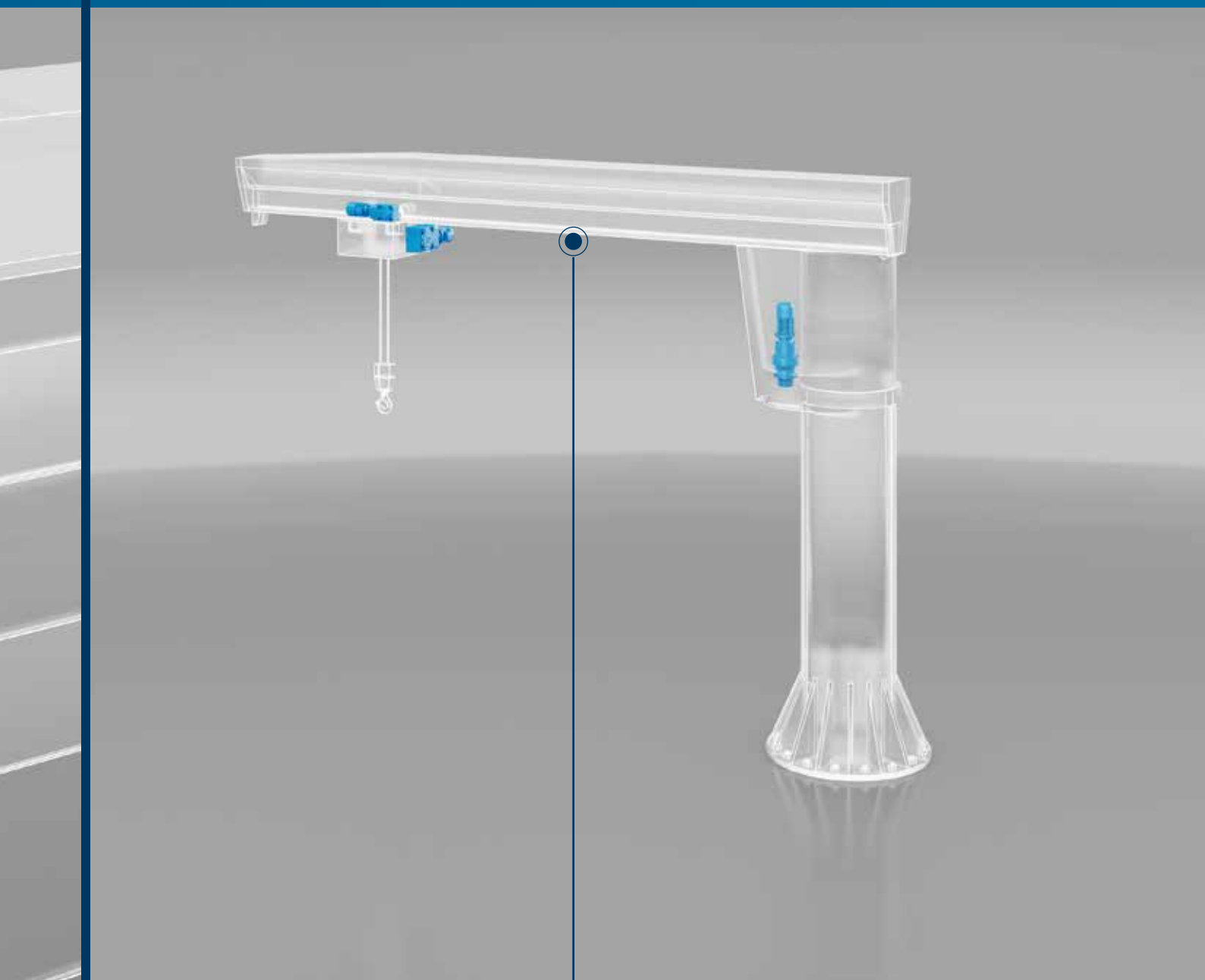

2 JIB CRANES

1

## OVERHEAD CRANES

Components in overhead indoor cranes have strict space-optimization requirements. Thanks to the mounting flexibility and compactness of our products, our customers will always find the solution that best meets their space requirements. To further increase efficiency, Bonfiglioli can also provide regenerative units to save the energy generated when lowering loads.

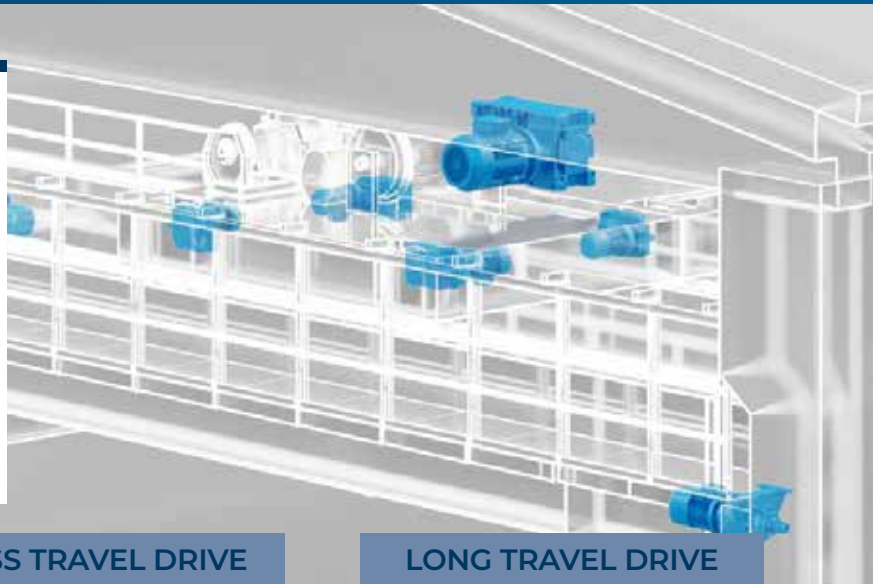

### HOIST DRIVE

### CROSS TRAVEL DRIVE

### LONG TRAVEL DRIVE



**HDP Series**  
Heavy Duty Geared Motor  
(Helical-Parallel)



**F Series**  
Shaft Mounted Gearbox



**300M Series**  
Planetary Gearbox

#### BENEFITS

- Robustness
- Reliability in harsh working conditions and wide range of temperature
- Space effective U-shape arrangement
- High overhung load capacity
- Tailored service and warranty plans
- Pre-sales and product definition support according to the material handling and lifting standards

- High efficiency
- Reliability and robustness
- Compactness
- Low maintenance

- Robustness
- Reliability in harsh working conditions & wide range of temperature
- High torque density
- Modularity
- High overhung load capacity

#### FEATURES

- Double input and output shaft
- Wide range of ratios
- Transmissible torque up to 210.000 Nm
- IEC or NEMA motor flange
- Safety solutions according to the customer requirements
- Wide range of motion control solutions
- Availability of different grade of protection

- Shaft mounted solution with different output configurations
- Housing integrated torque arm design and anti-vibration kits
- Wide range of ratios
- Availability of different grade of protection
- Compact or IEC/NEMA flanged motor adaptors

- Widest range of ratios
- Easy to fit output pinion
- IEC or NEMA motor flange
- Wide range of motion control solutions
- Availability of different grades of protection

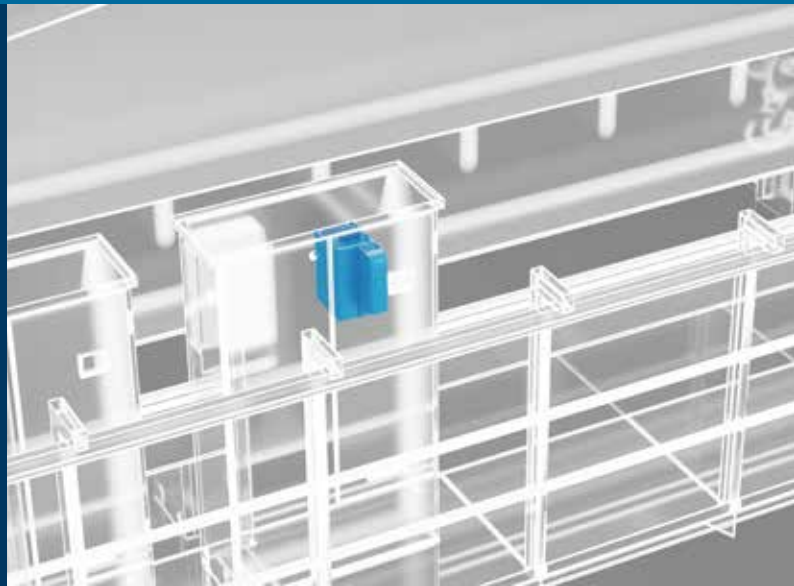
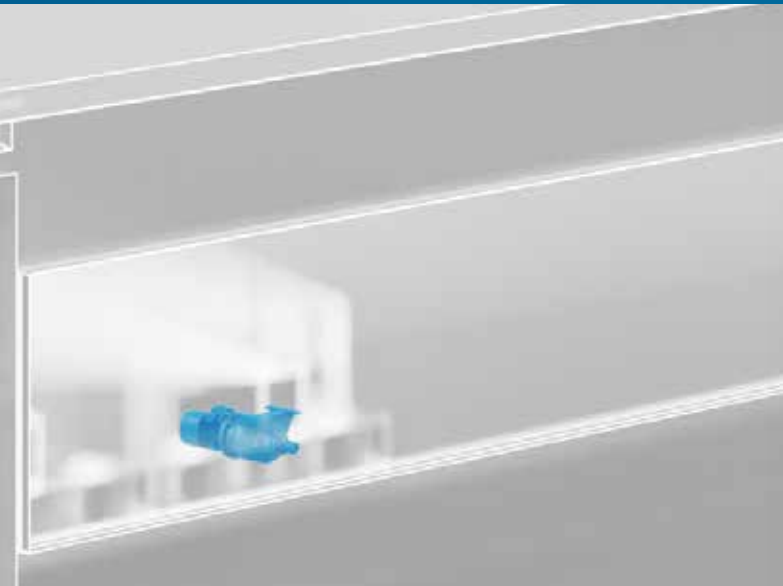

## **BX Series**

Asynchronous Induction Phase Motor

### **BENEFITS**

- Reliable, balanced and robust
- Compliant with the most of the efficiency standards

### **FEATURES**

- Power range: up to 355 kW
- Built in DC brakes
- Wide range of options
- Degree of protection up to IP56



## **AxiaVert Series & AEC Series**

High Performance Cabinet Inverter and Regenerative Units

- Modular system
- Wide power range
- Versatile Communication
- High mounting flexibility

- Selectable Functional safety features (up to SIL 3 / PL e / CAT. 4)
- Wide range of Encoder supports for various systems
- Customizable logic functions with internal optional PLC (IEC61131)
- Integrated PID control system
- Various Control modes incl. Position, Speed or Torque Control & CiA402-compatible Motion Control
- Easy wiring with detachable signal and power terminals (up to 15 kW)
- DC link connection for energy sharing
- Energy recovery braking (recovered electricity can be sent back to the grid)
- Energy consumption optimization (AEC/B)
- Mains unit (AEC/S)

2

## JIB CRANES

Bonfiglioli solutions for horizontal and low handling applications are cost-effective, compact and reliable.

Our products are designed to meet and exceed the demanding requirements for these cranes: from the high radial loads, of the slew drive to the precision necessary in the hoisting speed control and finally the dynamics of the cross travel drive.

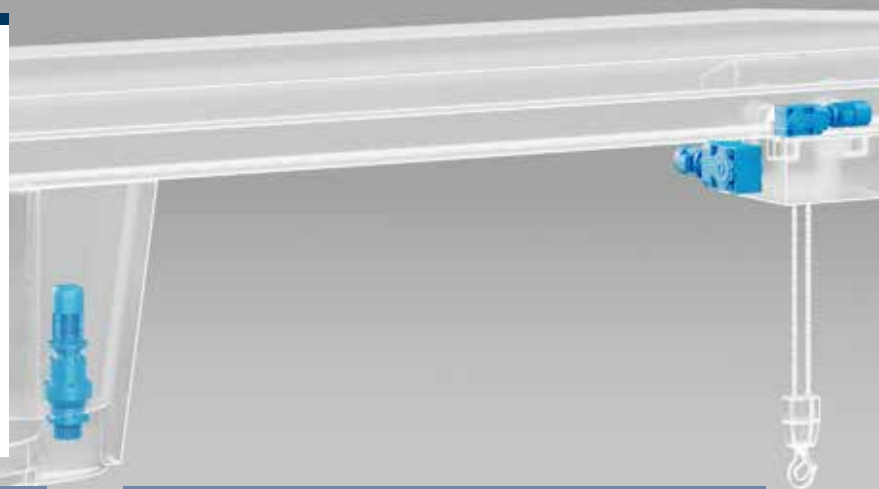

SLEW DRIVE

TRAVEL DRIVE & HOIST DRIVE



**300M Series**  
Planetary Gearbox



**A Series**  
Helical Bevel Gearbox

### BENEFITS

- Robustness
- Reliability in harsh working conditions and wide range of temperature
- High torque density
- Modularity
- High overhung load capacity

### FEATURES

- Widest range of ratios
- Easy to fit output pinion
- IEC or NEMA motor flange
- Wide range of motion control solutions
- Availability of different grades of protection

- Reduced installation space
- Wide output speed range
- High stiffness for dynamic application
- Safe operation in potentially explosive atmospheres

- Shaft mounting with hollow shaft and torque arm or shrink disk
- Reinforced bearings available as an option
- Reduced backlash as an option

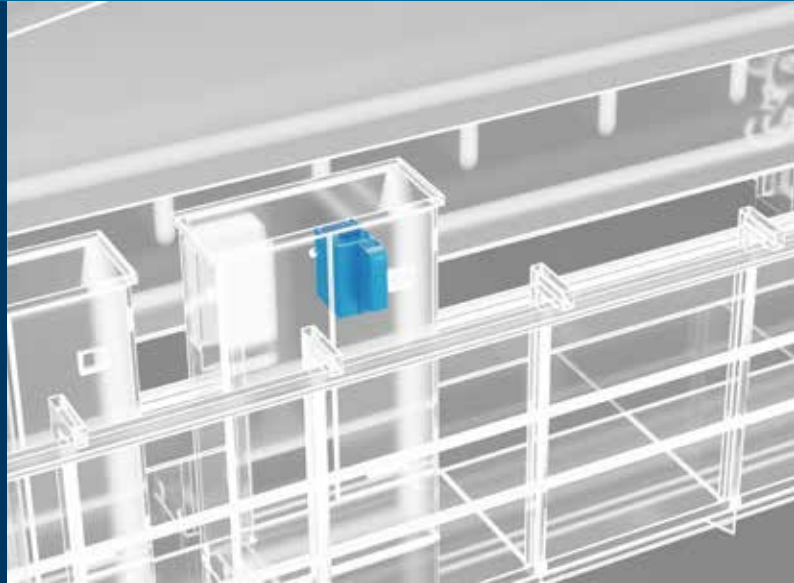
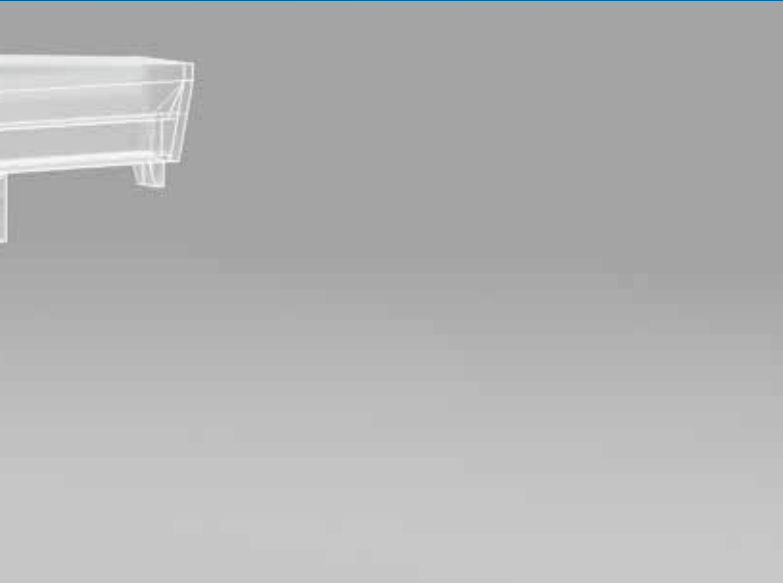

## **BX Series**

Asynchronous Induction Phase Motor

### **BENEFITS**

- Reliable, balanced and robust
- Compliant with the most of the efficiency standards

### **FEATURES**

- Power range: up to 355 kW
- Built in DC brakes
- Wide range of options
- Degree of protection up to IP56



## **AxiaVert Series & AEC Series**

High Performance Cabinet Inverter and Regenerative Units

- Modular system
- Wide power range
- Versatile Communication
- High mounting flexibility

- Selectable Functional safety features (up to SIL 3 / PL e / CAT. 4)
- Wide range of Encoder supports for various systems
- Customizable logic functions with internal optional PLC (IEC61131)
- Integrated PID control system
- Various Control modes incl. Position, Speed or Torque Control & CiA402-compatible Motion Control
- Easy wiring with detachable signal and power terminals (up to 15 kW)
- DC link connection for energy sharing
- Energy recovery braking (recovered electricity can be sent back to the grid)
- Energy consumption optimization (AEC/B)
- Mains unit (AEC/S)

# Our worldwide presence

Thanks to an international network of closely interconnected commercial and production sites, we can guarantee the same high standards of Bonfiglioli quality anywhere at any given time. We know that our direct presence in local markets is the key to long-lasting success, so our family includes 17 production sites, 23 commercial sites and more than 550 distributors around the world.

**Our organization is always close by, offering complete and efficient solutions and supporting our customers with dedicated services, co-engineering and after-sales assistance.**

17  PRODUCTION SITES

23  COMMERCIAL SITES

80  COUNTRIES

550  DISTRIBUTORS

~5,000  PEOPLE



# Bonfiglioli global locations

## AUSTRALIA

**Bonfiglioli Transmission (Aust.) Pty Ltd**  
Plumpton NSW



## BRAZIL

**Bonfiglioli Redutores do Brasil Ltda**  
São Bernardo do Campo - São Paulo



## CHINA

**Bonfiglioli Drives (Shanghai) Co. Ltd.**  
Shanghai



**Selcom Electronics (Shanghai) Co., Ltd**  
Shanghai



Shanghai



## FRANCE

**Bonfiglioli Transmission S.A.S.**  
Marly la Ville



## GERMANY

**Bonfiglioli Deutschland GmbH**  
Neuss



**Bonfiglioli Deutschland GmbH**  
Krefeld



**O&K Antriebstechnik GmbH**  
Hattingen



## INDIA

**Bonfiglioli Transmission Ltd.**  
**Mobility & Wind Industries**

Thirumudivakkam  
Kancheepuram - Tamil Nadu



**Industry & Automation Solutions**  
Mannur Village, Sriperumbudur Taluk  
Kancheepuram - Tamil Nadu



**Industry & Automation Solutions**  
Pune - Maharashtra



## ITALY

**Bonfiglioli Riduttori S.p.A.**  
**Industry & Automation Solutions**  
Calderara di Reno (BO)



**Industry & Automation Solutions**  
Carpiano



**Mobility & Wind Industries**  
Forlì



**Industry & Automation Solutions**  
Rovereto



**Selcom Group S.p.A.**  
Castel Maggiore (BO)



Castel Maggiore (BO)



Cadriano (BO)



## NEW ZEALAND

**Bonfiglioli Transmission (Aust.) Pty Ltd**  
Auckland - Ellerslie



## SINGAPORE

**Bonfiglioli South East Asia Pte Ltd**  
Singapore



## SLOVAKIA

**Bonfiglioli Slovakia s.r.o.**  
Považská Bystrica



## SOUTH AFRICA

**Bonfiglioli South Africa Pty Ltd.**  
Johannesburg



## SPAIN

**Tecnotrans Bonfiglioli S.A**  
Castellbisbal - Barcelona



## TURKEY

**Bonfiglioli Türkiye Jsc**  
Çiğli - Izmir



## UNITED KINGDOM

**Bonfiglioli UK Ltd.**  
Warrington - Cheshire  
Tel. +44 1925 852667



## USA

**Bonfiglioli USA Inc.**  
Hebron - Kentucky



## VIETNAM

**Bonfiglioli Vietnam Co. Ltd.**  
Ben Cat city, Binh Duong province





We have a relentless commitment to excellence, innovation & sustainability. Our team creates, distributes and services world-class power transmission & drive solutions to keep the world in motion.

#### HEADQUARTERS

##### **Bonfiglioli S.p.A**

Via Cav. Clementino Bonfiglioli, 1  
40012 Calderara di Reno - Bologna (Italy)  
Tel. +39 051 6473111

