



SOLUTIONS FOR
Mining
Industry





We engineer dreams



Contents

MINING INDUSTRY	5
EARTH MOVING MACHINES.....	6
Large excavators and mining shovels	8
Surface miners	9
Bucket wheel excavators	10
Jaw crusher.....	11
Road header	12
Drilling machines	13
CRUSHING & GRINDING & MATERIAL HANDLING	14
Bulk long distance conveying	16
Feeding.....	17
Crushing.....	18
Unloading	20
Positioning.....	22
Stacking & reclaiming	21
SLURRY PROCESSES	24
Dewatering (Belt filter solutions).....	26
Dewatering (Spiral classifier solutions).....	27
Thickening	28
Flotation	29
OUR GLOBAL PRESENCE.....	30

Engineering Solutions



WWW.BONFIGLIOLI.COM



Mining Industry

THE WIDEST RANGE OF SOLUTIONS FOR THE MINING INDUSTRY

With decades of experience in developing customized solutions for the most demanding mining applications around the world, Bonfiglioli can offer its customers a wide, complete, well-adapted range of solutions.

From crushing to slurry processes to earth moving applications, our team of experts designs and creates integrated solutions that take on the harsh, dusty environments typical of mining applications.

Bonfiglioli's final drive, gearbox, geared motor or motion and control solutions are recognized on the market by worldwide leading players, with whom we've been working for decades. Today, our range of products is one of the largest available worldwide, with torque values from 13 Nm to 3,000,000 Nm.



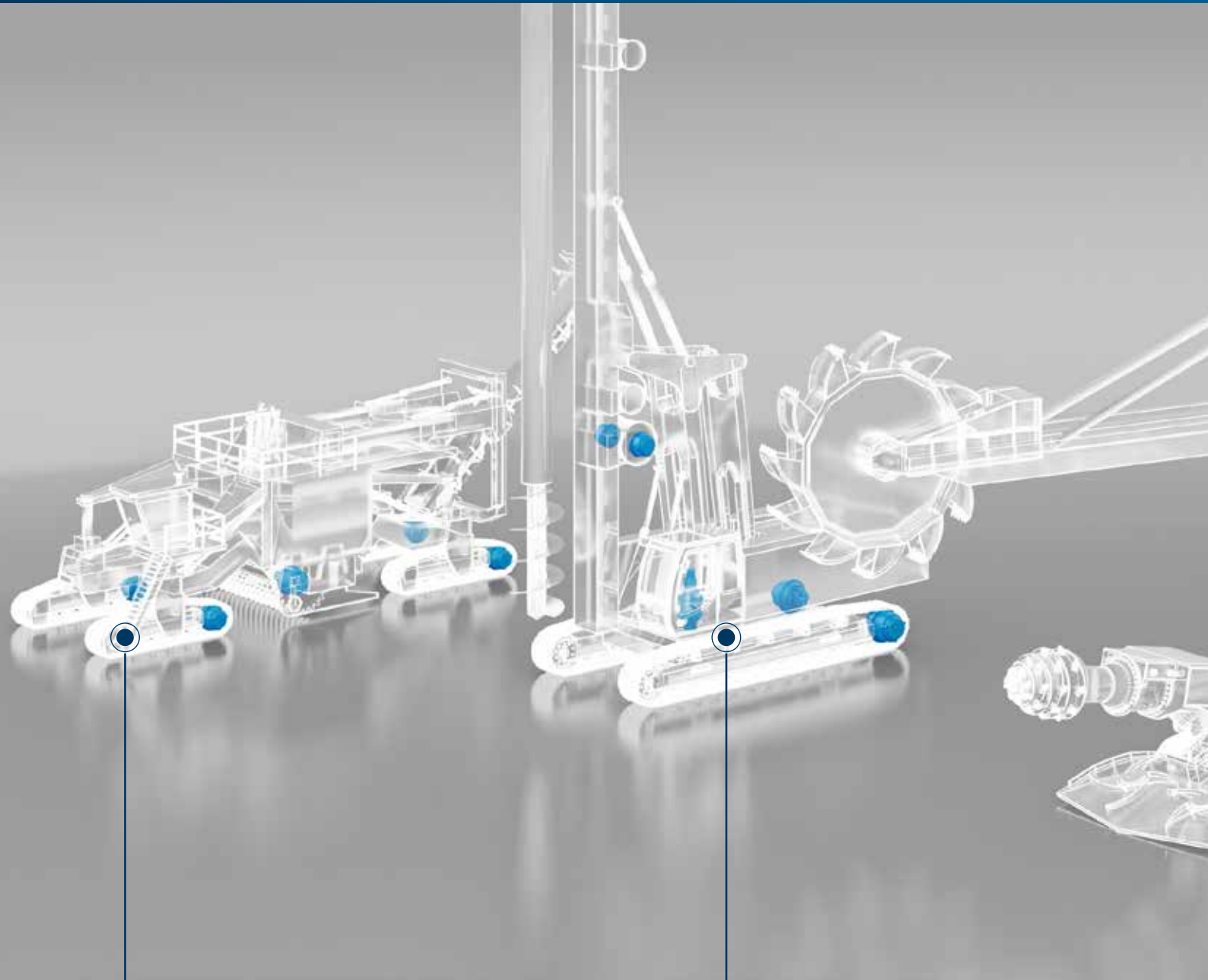

2 SURFACE MINERS

6 DRILLING MACHINES

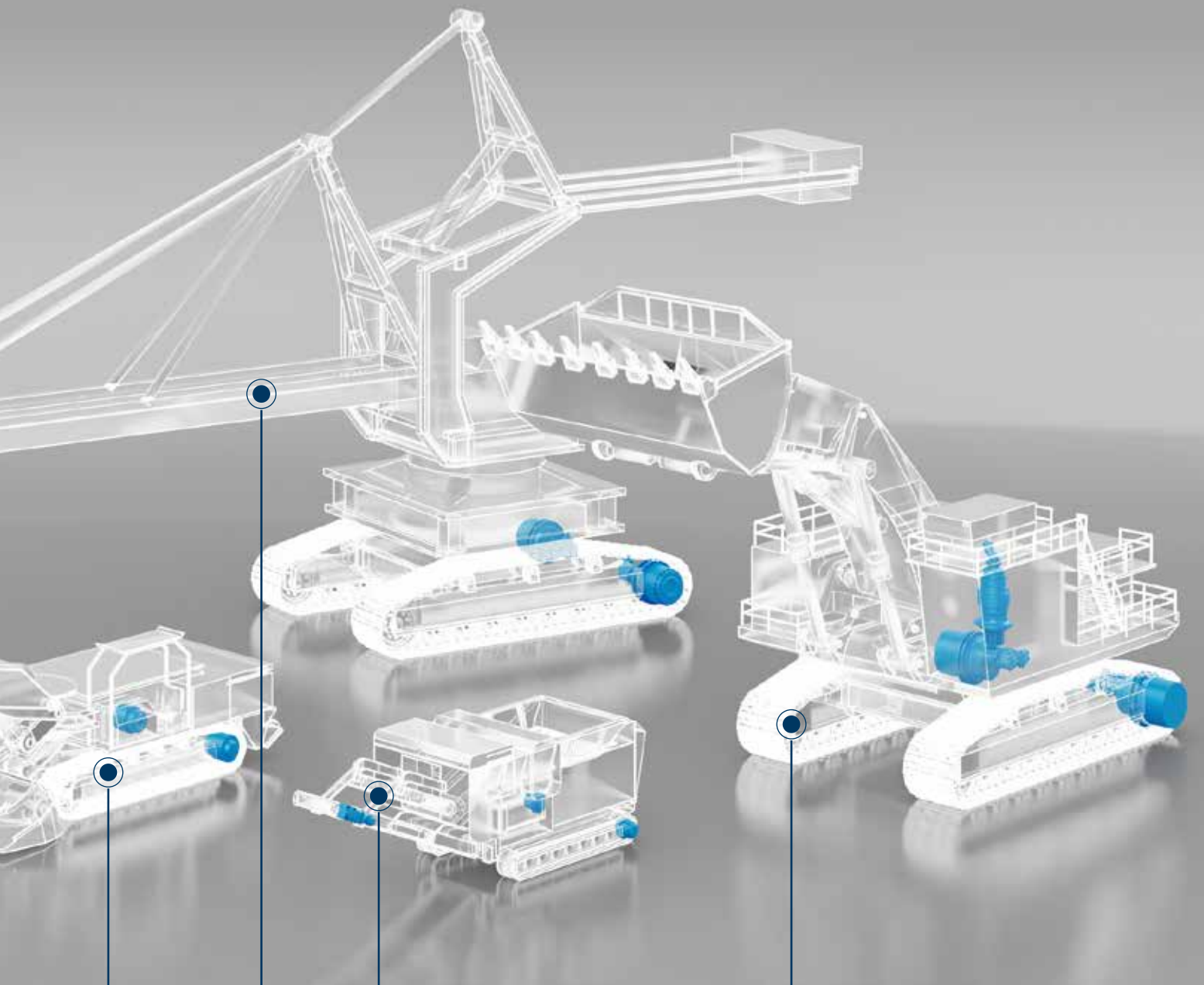

4 JAW CRUSHER

3 BUCKET WHEEL EXCAVATORS

1 LARGE EXCAVATORS AND MINING SHOVELS

5 ROAD HEADER

1

LARGE EXCAVATORS AND MINING SHOVELS

Track drives

Bonfiglioli solutions for large tracked excavators are compact while delivering high performance. The wide variety of ratio combinations allows our solutions to offer the best possible efficiency.

Slew drives

Compactness and high performance are the two main features of Bonfiglioli solutions for large excavator applications.

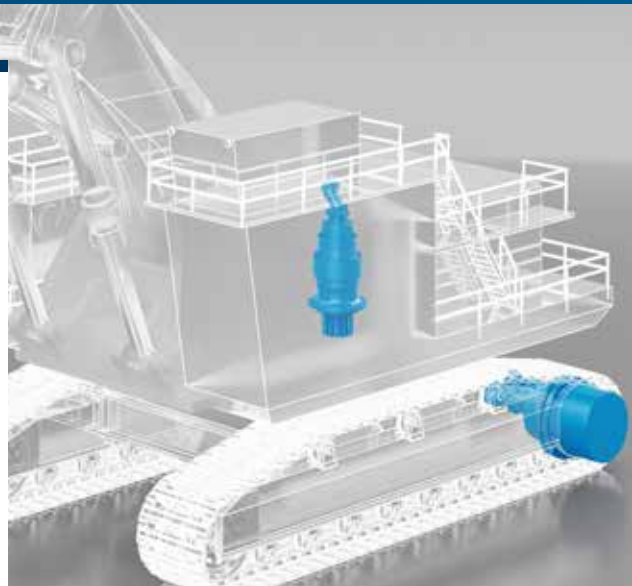

F Series

Travel & Track drives



700T Series

Slew drives

BENEFITS

- Power shift capability
- Compact solution
- High performance

FEATURES

- Two gear shifting transmission
- Hydraulically controlled shifting
- Integrated parking & emergency brake
- Optional cooling flow to input stage and clutch unit
- Wide variety of ratio combinations

- Compact structure
- Suitable for various hydraulic motors
- High performance

- Notchless ground tooth root
- Integrated disc-brake
- High availability on highest teeth and production quality

2

SURFACE MINERS

Travel drives

Bonfiglioli solutions for tracked surface miners are compact while delivering high performance. The wide variety of ratio combinations allows our solutions to offer the best possible efficiency.

Cutter drives

Compactness and high performance are the two main features of Bonfiglioli cutter drives for surface miners. Tailored to the hardness of the material to be mined, these solutions are customized to satisfy customer-specific requirements.



700C Series
Travel drives



FA Series
Cutter drives

BENEFITS

- Power shift capability
- Compact solution
- High performance

FEATURES

- Two gear shifting transmission
- Hydraulically controlled shifting
- Integrated parking & emergency brake
- Optional cooling flow to input stage and clutch unit
- Wide variety of ratio combinations

- Compact structure
- High performance
- High availability on highest teeth and production quality

- Notchless ground tooth root
- Different ratios
- Integrated disc-brake
- Suitable for various hydraulic motors

3

BUCKET WHEEL EXCAVATORS

Track drives

Bonfiglioli solutions for bucket wheeled excavators are compact while delivering high performance. The wide variety of ratio combinations allows our solutions to offer the best possible efficiency.

All units are available with a fail-safe parking brake.

Different disengagement systems are available on demand for all sizes.

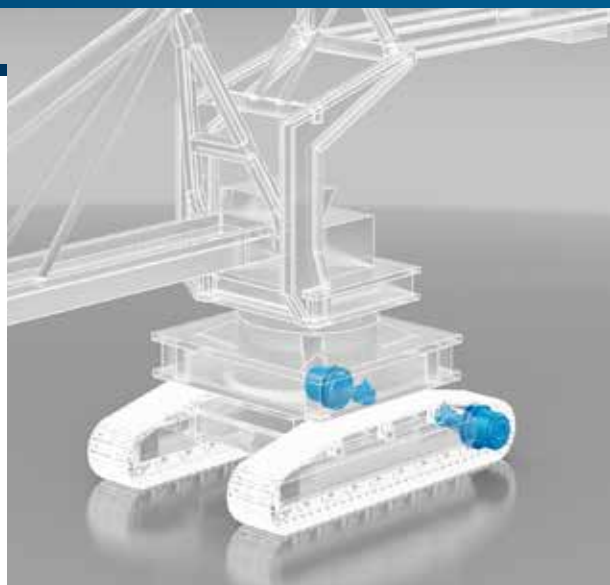

FP Series

Track drives

BENEFITS

- Power shift capability
- Compact solution
- High performance

FEATURES

- Two gear shifting transmission
- Hydraulically controlled shifting
- Integrated parking & emergency brake
- Wide variety of ratio combinations
- Mechanical disconnect device
- Low and high temperature versions

4

JAW CRUSHER

Track drives

Bonfiglioli solutions for tracked jaw crushers are compact while delivering high performance. The wide variety of ratio combinations allows our solutions to offer the best possible efficiency.

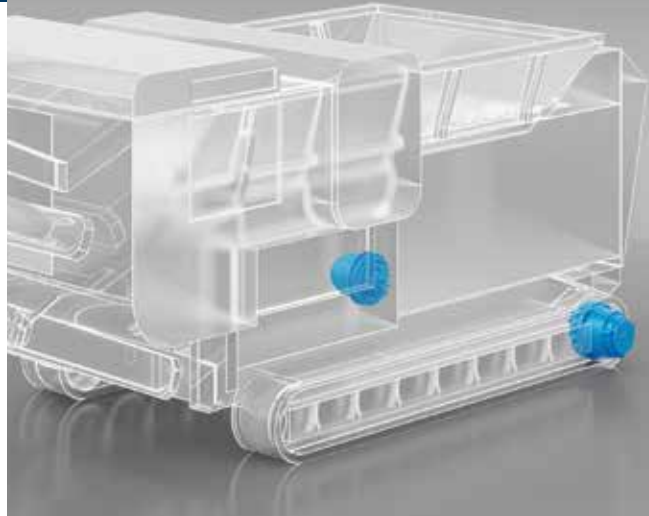

700CK Series
Travel & Track drives



800 Series
Conveyor drives

BENEFITS

- Rugged design
- High torque capacity
- High load capacity
- Lifelong mechanical seals
- Compact design

FEATURES

- Rotating output flange with large PCD suitable for sprocket
- KAYABA hydraulic motors
- Integrated axial piston hydraulic motors

- Rugged construction
- High torque capacity
- High load capacity

- Rotating housing flange
- Freewheel for anti run-back device, optional

5

ROAD HEADER

Bonfiglioli solutions for Road Headers are compact while delivering high performance. The wide variety of ratio combinations means our solution offers the best possible efficiency.

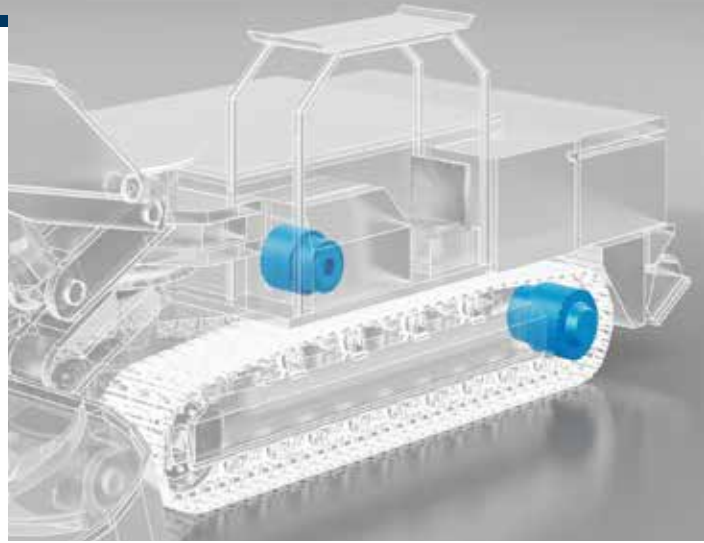

F Series

Travel & Track drives

BENEFITS

- Power shift capability
- Compact solution
- High performance

FEATURES

- Two gear shifting transmission
- Hydraulically controlled shifting
- Integrated parking & emergency brake
- Wide variety of ratio combinations
- Mechanical disconnect device
- Optional cooling flow to input stage and clutch unit

6

DRILLING MACHINES

Winch

The FW Series planetary winch gearboxes are available with a large spectrum of torques. The compact design allows the gearbox to be integrated into the winch drum. The fail-safe brake can be integrated inside the gearbox or mounted externally.

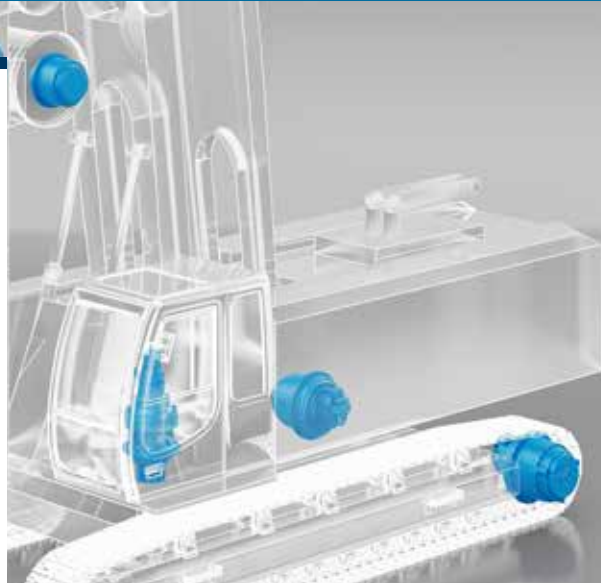

700C Series
Travel & Track drives



700C Series
Slew drives



FW Series
Winch drives



300 Series
Rotary drives

BENEFITS

- Power shift capability
- Compact solution
- High performance

- Compact structure
- Suitable for various hydraulic motors
- High performance

- Compact structure
- Robust planetary gear unit layout
- Robust tape roller bearings for drum support and cable pull

- Highly transmissible torque and power
- Compact design
- Cooling-system free
- Integrated brake solution
- Wide range of temperature & working conditions

FEATURES

- Two gear shifting transmission
- Hydraulically controlled shifting
- Integrated parking & emergency brake
- Optional cooling flow to input stage and clutch unit
- Wide variety of ratio combinations

- Notchless ground tooth root
- Integrated disc-brake
- High availability on highest teeth and production quality

- Integrated disc-brake
- Easy oil change from the front
- Easy drum mounting
- High variety of ratios
- Electrically and hydraulically driven solutions
- In-line and right-angle configurations
- Interchangeable solutions available

- New e-motor flange with integrated fan
- Increased bearing load capability
- Specific design for disc-brake integration
- Nominal torque up to 1,300,000 Nm
- Modular design
- Oil expansion tank & oil level switch

SOLUTIONS FOR Mining industry

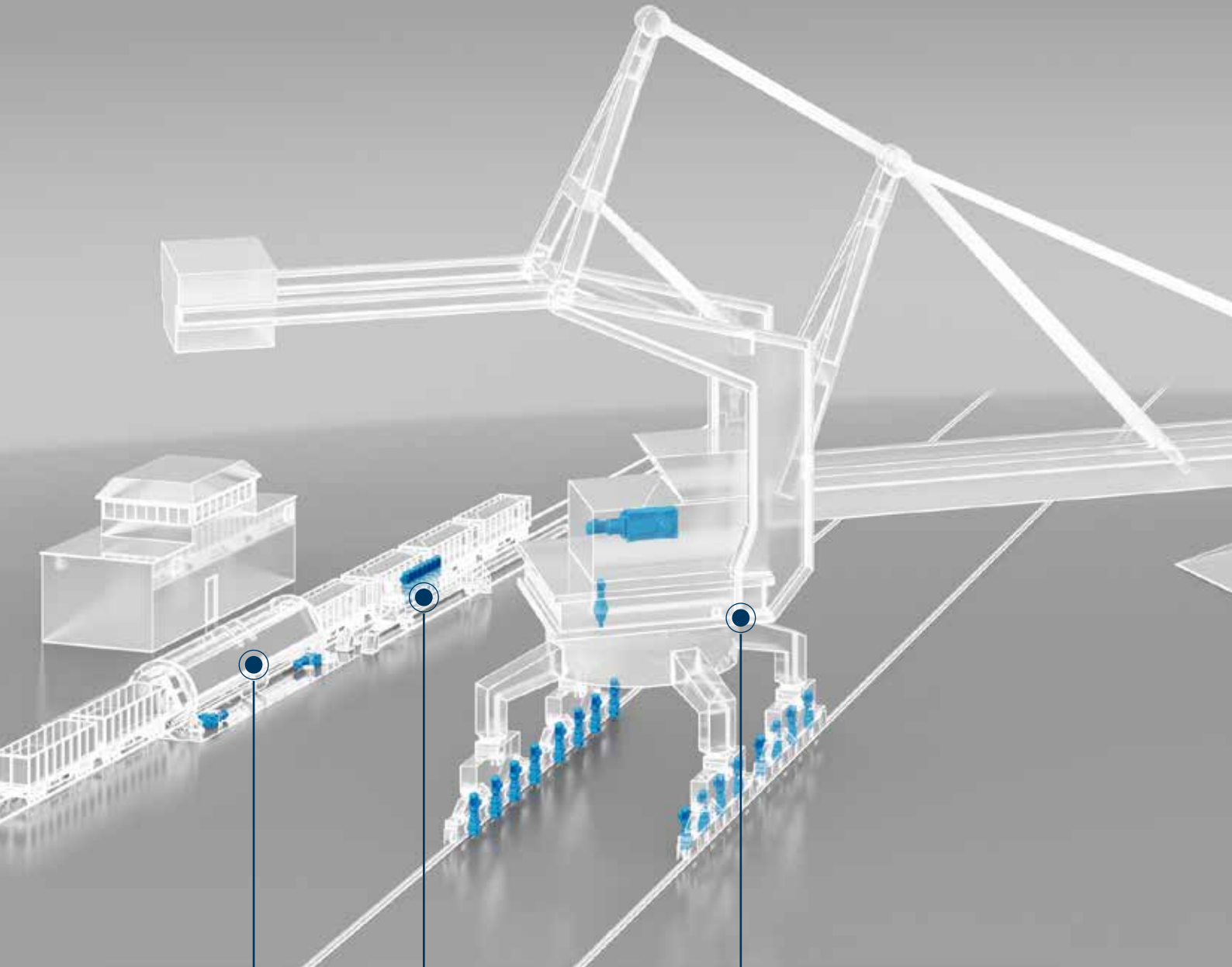

4 UNLOADING

5 POSITIONING

6 STACKING & RECLAIMING

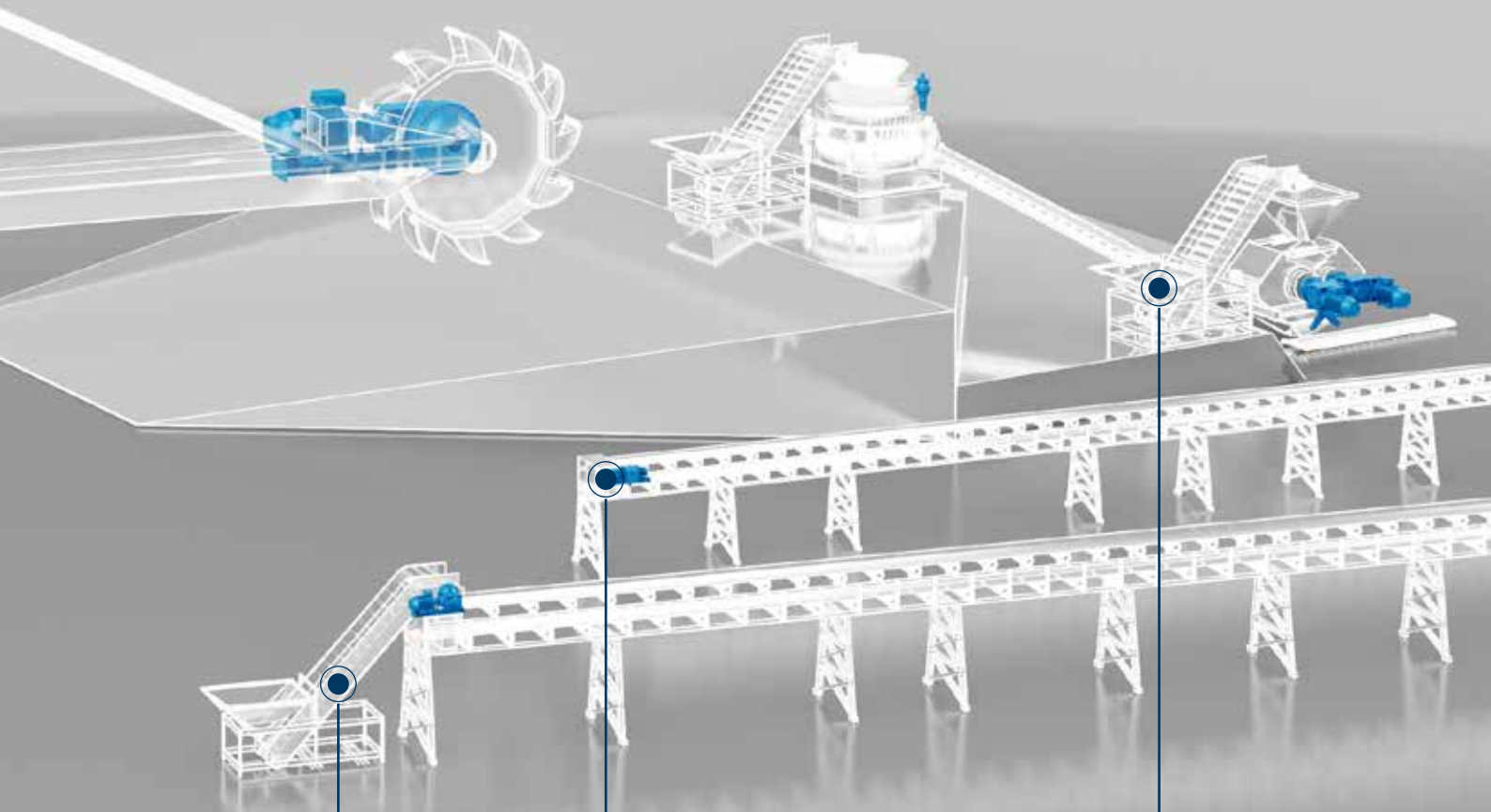

2 FEEDING

1 BULK LONG DISTANCE
CONVEYING

3 CRUSHING



1

BULK LONG DISTANCE CONVEYING

Overland conveyors are suited for moving large quantities of materials over long distances. Reliably moving large quantities of materials over long distances in the power and mining industries is an everyday necessity. Mining and construction industries worldwide use overland conveyors. Their mining-type structure make them the ideal choice for many applications. The components we use in our underground conveyors are of the same high quality, expertly designed and pre-engineered for many of these overland conveyors and normally available for rapid shipment. These conveyors offer significant economies of scale for site preparation and installation. After assessing truck versus belt haulage, companies are increasingly turning to overland conveyors.



HD Series Conveyor drives

BENEFITS

- Powerpack key turn
- Works in all conditions -40°C/+40°C
- Dust proof
- Increased bearing load capability

FEATURES

- Fluid coupling for a soft start
- Brake
- Baseplate
- Taconite seals
- Heating device / Axial fan

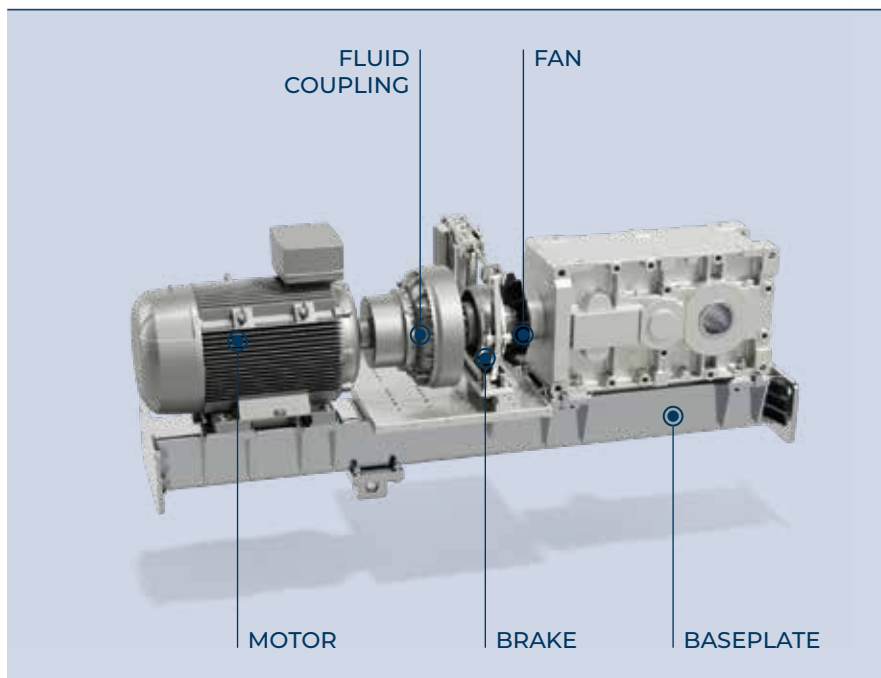

2

FEEDING

Bonfiglioli is an expert on issues related to these applications: the high breaking torque required at start-up, the high load shocks caused by falling material and the dusty mine environments are just a few of the challenges that our products can successfully overcome. We supply complete solutions for feeders and conveyors with integrated base plates and torque arms protected against harsh environments, with special seals and paints to simplify machine design for our customers.

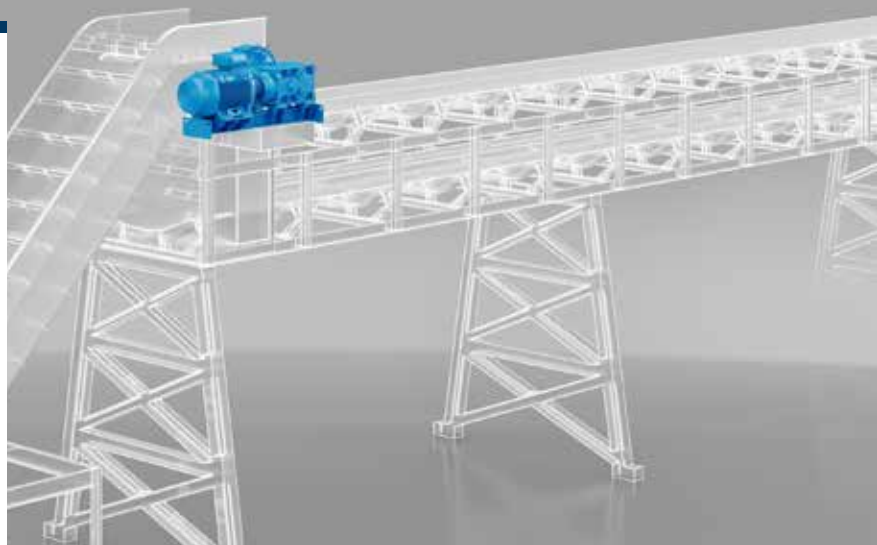

3/H Series Feeder drives

BENEFITS

- Extremely high transmissible torque and power
- Suitable for all heavy-duty applications
- High shock resistance
- Reliability
- Easy maintenance
- High level of customization

FEATURES

- New e-motor flange with integrated fan
- Increased bearing load capability
- Nominal torque up to 1,300,000 Nm
- Modular design

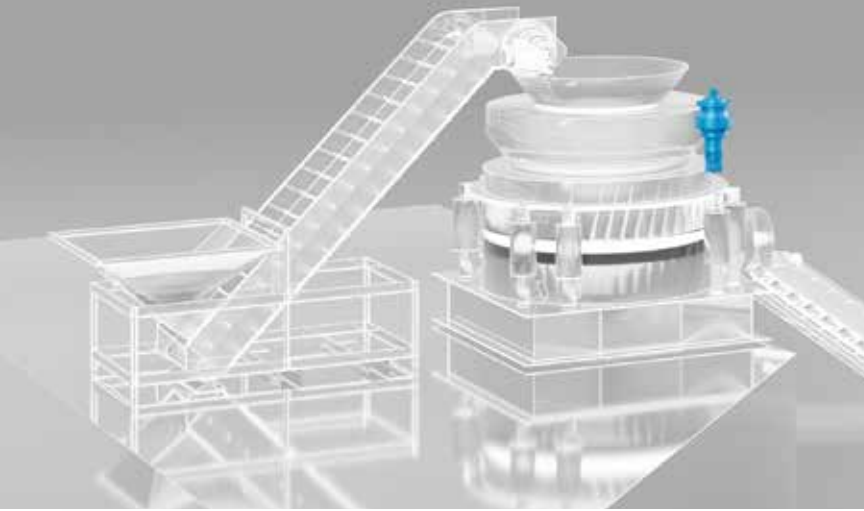

3

CRUSHING

Crushing is a crucial process in the mineral industry, so reliability of the products for these applications must be extremely high to ensure process continuity. Bonfiglioli solutions for crushers are extremely robust and manufactured to the highest quality criteria. Our heavy-duty products for these applications can operate 24/7/365 and ensure maximum operational time. Furthermore, our solution can be customized with torque arms suited to the machine design, completed with highly corrosion-resistant paints and seals for mining environments.



300 Series Crusher drives

BENEFITS

- Highly transmissible torque and power
- Compact design
- Cooling-system free
- Integrated brake solution
- Wide range of temperature & working conditions

FEATURES

- Increased bearing load capability
- Specific design for disc-brake integration
- Nominal torque up to 1,300,000 Nm
- Modular design
- Oil expansion tank & oil level switch
- Electric or hydraulic version available

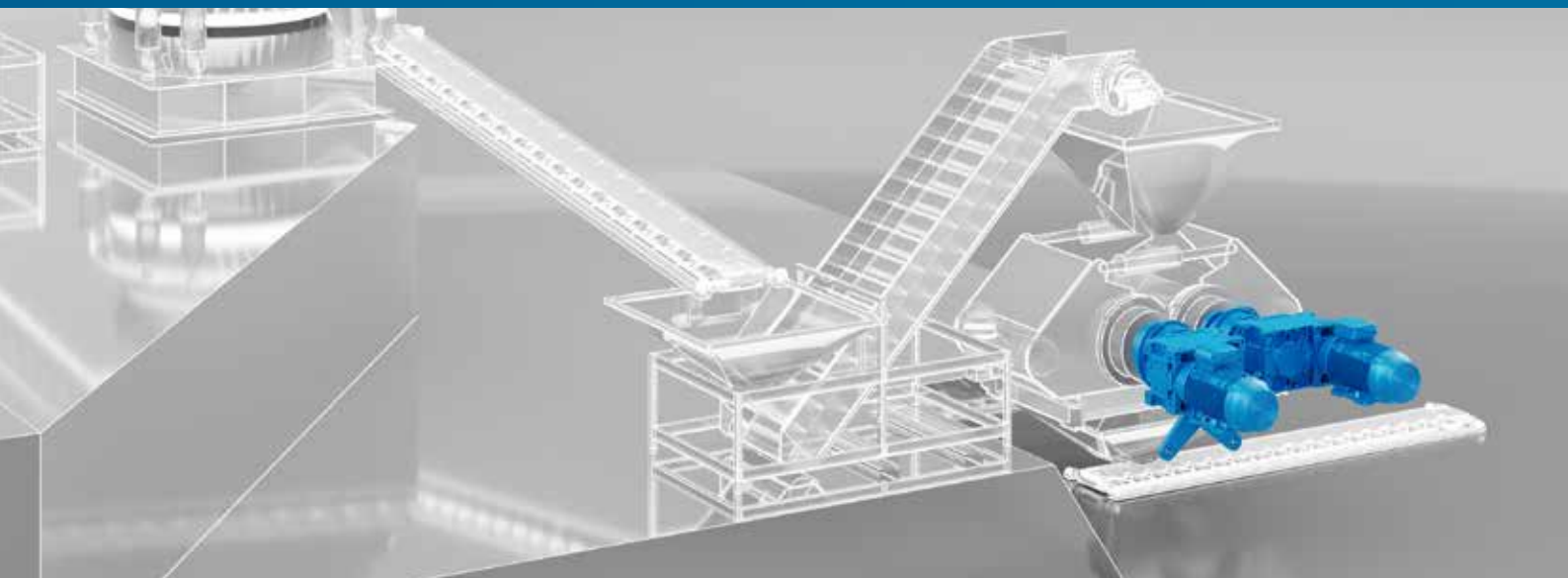

3/H Series Crusher drives

BENEFITS

- Extremely high transmissible torque and power
- Suitable for all heavy-duty applications
- High shock resistance
- Reliability
- Easy maintenance
- High level of customization

FEATURES

- New e-motor flange with integrated fan
- Increased bearing load capability
- Nominal torque up to 1,300,000 Nm
- Modular design
- Oil expansion tank & oil level switch
- Double torque arm customizable



4

UNLOADING

Unloading procedures in a mining plant are usually done by a train positioner coupled with a wagon tippler.

Bonfiglioli solutions for train positioners have customized gearmotors adapted to the machine design. Furthermore, the products we use in these applications feature special seals.

Wagon tripler:

Wagon triplers rotate train cars together with the rail section beneath them to unload the material.



HDP Series

Car Dumper drives

BENEFITS

- High transmissible power
- Robustness
- Mounting flexibility
- High level of customization
- Reliability
- ATEX for 2G/2D explosive atmospheres

FEATURES

- Fan cooling, cooling coil, oil heater
- External cooling unit
- Backstop
- Temperature and oil level sensors
- Taconite seals
- Double input shaft
- Brake options

5

POSITIONING

Positioners are placed just before the car dumper to hook up 2 to 3 train cars filled with bulk material to bring them to the car dumper where they are rotated and emptied.

Set in a series of 10 to 15 units by meshing on a rack on the side of the rails, the gearboxes move the car forward and backward cyclically. The high running speeds (up to 3000 rpm) and the significant torques involved require specially designed gearboxes with specific outputs and dedicated accessories such as brakes and torque limiters.



300M Series

Planetary gearbox and geared motor

BENEFITS

- Highly transmissible torque and power
- Compact design
- Cooling-system free
- Integrated brake solution
- Wide range of temperature & working conditions

FEATURES

- Increased bearing load capability
- Specific design for shoe brake integration
- Nominal torque up to 1,300,000 Nm
- Modular design
- Oil expansion tank & oil level switch
- Customized pinion available as an option
- Extended output available as an option

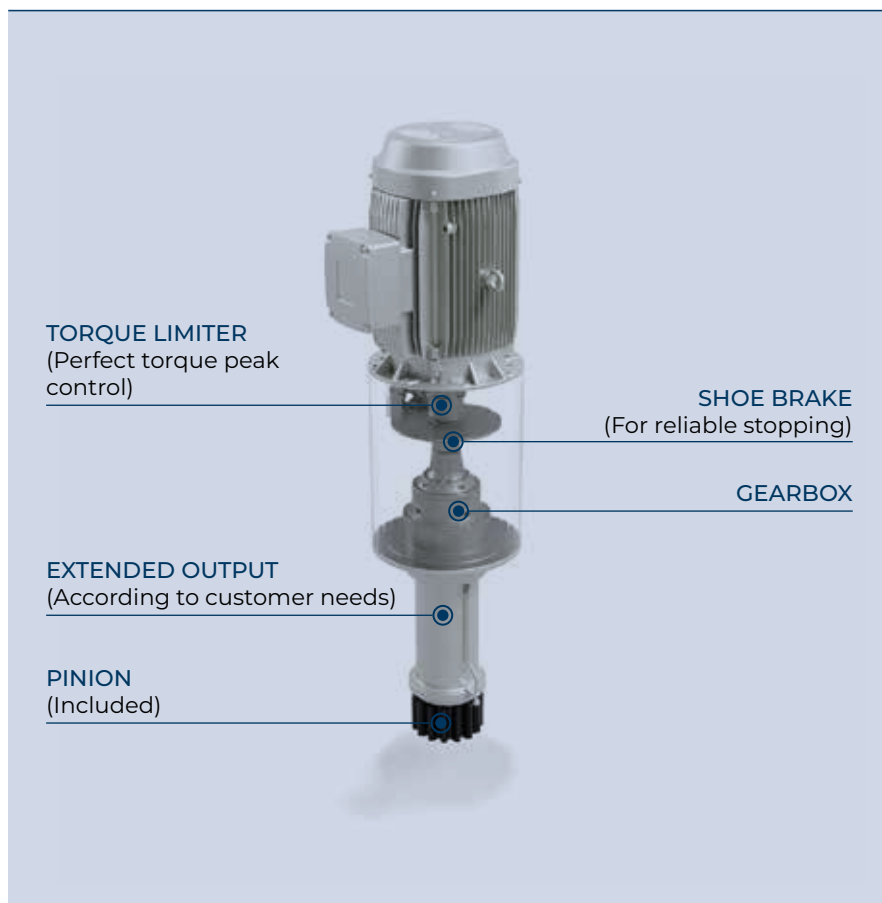

6

STACKING & RECLAIMING

Multi-functional machines, such as stackers/reclaimers, store and gather material in large mining processes. Bonfiglioli can provide solutions for all stacker/reclaimer drives. The products we supply are tailored to meet the specific requirements of each machine drive: different brakes, forced lubrication, integrated base plates, cooling fans and oil expansion tanks are just a few examples of how we can meet our customers' needs. Finally, all the solutions can be further customized with a set of features specifically developed to resist the harsh mining environment.

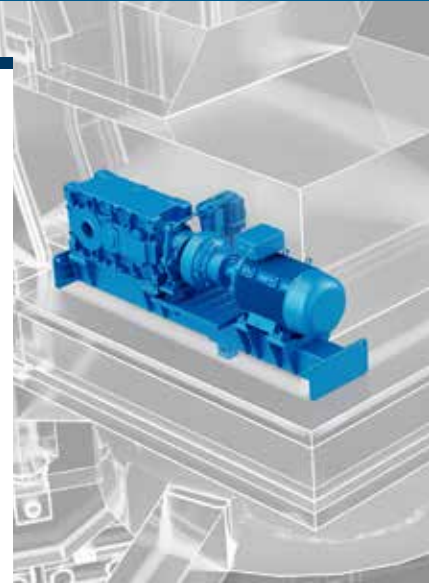

3/H Series
Bucket wheel drive



HDO Series
Boom Conveyor drives

BENEFITS

- One-stop shop for complete drive solutions
- Extended oil service interval
- Maintenance-free cooling device solution
- High overload capacity
- Highly transmissible torque and power

FEATURES

- Modular design
- Shock load up to 2,000,000 Nm
- Increased bearing load capability
- Wide range of optionals
- Integrated forced oil lubrication
- Torque arm, base frame, coupling, brake, motor

- Powerpack key turn
- Works in all conditions -40°C/+40°C
- Dust proof
- Increased bearing load capability

- Fluid coupling for a soft start
- Brake
- Baseplate
- Taconite seals
- Heating device / Axial fan

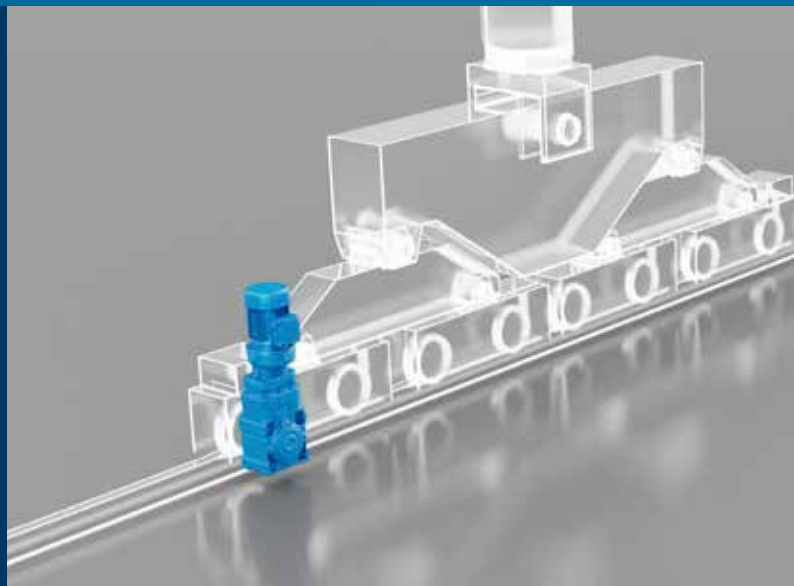

300 Series
Slew drives

BENEFITS

- Hydraulic or electric motor input solution
- High overload capacity
- Torque control
- Easy installation
- Brake available as an option

FEATURES

- Reinforced bearing output shaft
- Eccentric mounting flange option for pinion/girth gear adjustment
- Shock load up to 2,000,000 Nm
- Base frame, coupling, brake, motor
- Oil expansion tank & oil level switch



A Series
Travel drives

- Minimum mounting space
- Wide output speed selection range
- Reduced standard backlash
- High dynamic and energy saving solution
- ATEX gearbox for 2G/2D explosive environments

- Surface protection up to C5
- Reinforced bearings
- Reduced backlash
- Torque arm
- Fluor elastomer oil seals
- Double oil seals on input
- Taconite seals

SOLUTIONS FOR Mining industry

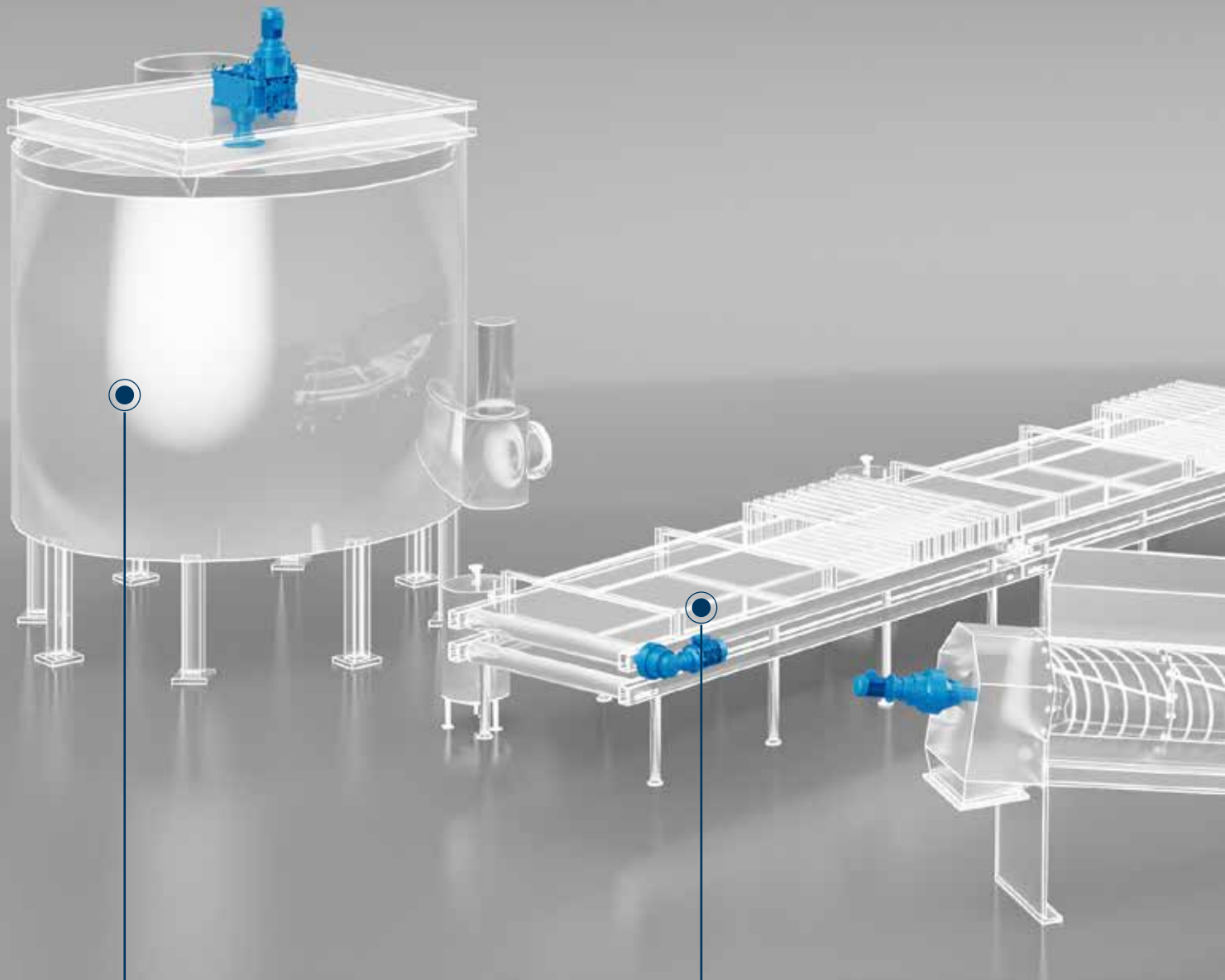

4 FLOTATION

1 DEWATERING
BELT FILTER SOLUTIONS

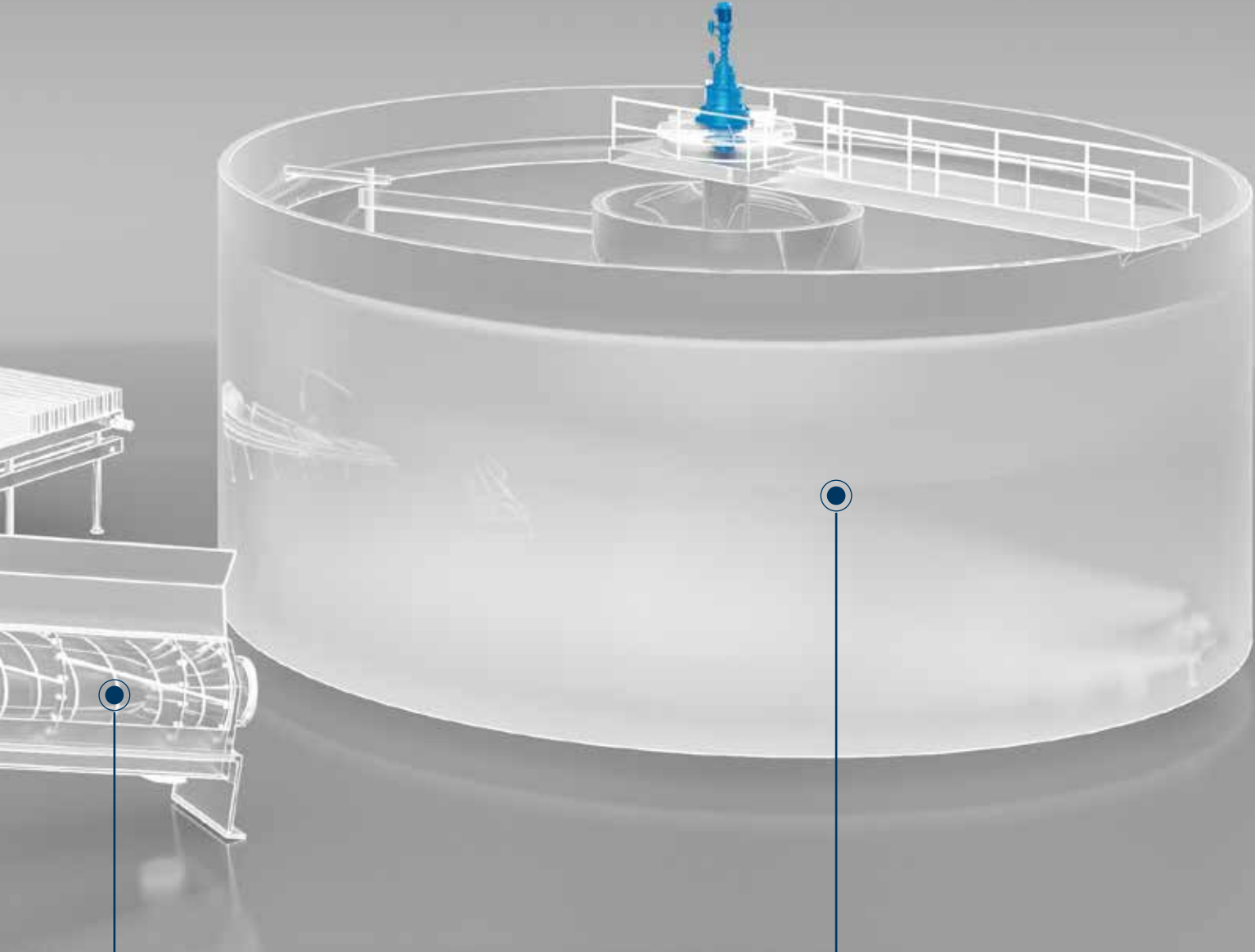

2 DEWATERING
SPIRAL CLASSIFIER SOLUTIONS

3 THICKENING

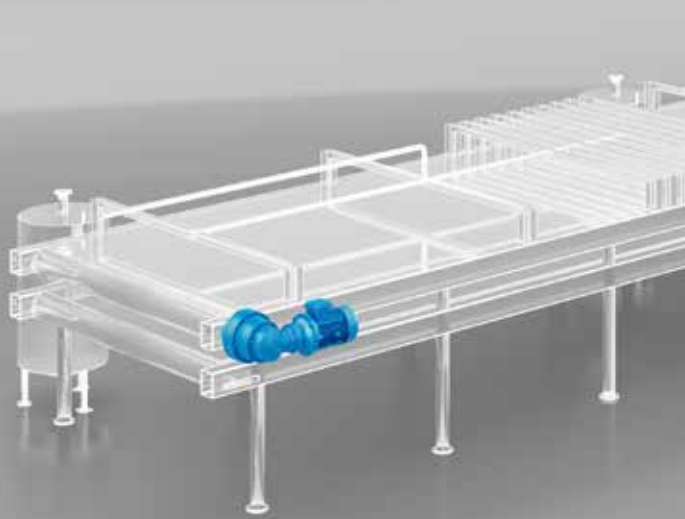

1

DEWATERING BELT FILTER SOLUTIONS

Focusing on solid/liquid separation, the belt filter presses the product with mechanical pressure to squeeze the water out of the sludge. Flexibility in layout and mounting positions as well as high resistance in harsh, dusty and ambient conditions are key features that our products can deliver.



300 Series Belt filter drives

BENEFITS

- Hydraulic or electric motor input solution
- High overload capacity
- Easy installation

FEATURES

- Reinforced bearing output shaft
- Shock load up to 2,000,000 Nm
- Oil expansion tank & oil level switch

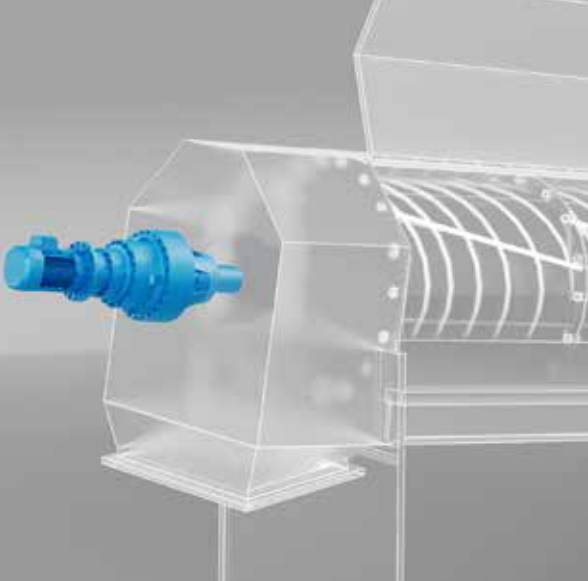

2

**DEWATERING
SPIRAL CLASSIFIER SOLUTIONS**

Spiral classifiers are designed to settle and dewater relatively coarse particles from high volume, low percent solid volume streams. Flexibility in layout and mounting positions as well as high resistance in harsh, dusty and ambient conditions are key features that our products can deliver.



**300 Series
Spiral filter Drives**

BENEFITS

- Hydraulic or electric motor input solution
- High overload capacity
- Easy installation

FEATURES

- Reinforced bearing output shaft
- Shock load up to 2,000,000 Nm
- Oil expansion tank & oil level switch

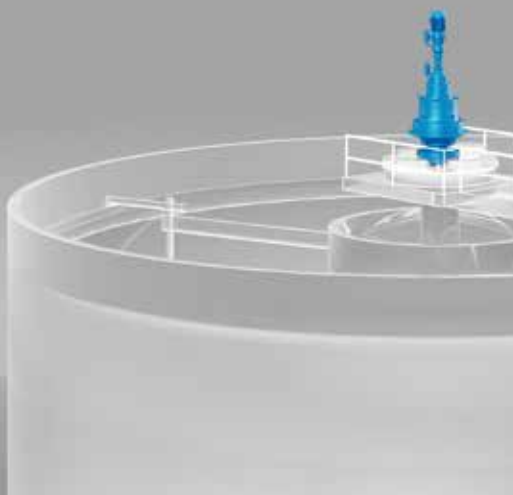

3

THICKENING

Separating the minerals from the water using gravity sedimentation means controlling the speed and, at the same time, facilitating precise movements. For this application Bonfiglioli offers vertical linear planetary gearboxes with very high reduction ratios to obtain speeds of <1 rpm on the output shaft, with particular attention to possible torque overloads, depending on the solid material layer thickness moved by the rake.



300M Series Thickener drives

BENEFITS

- High shock load capability
- Extended life & reliability
- Torque control
- Electric and Hydraulic version available
- Integrated pinion available as an option

FEATURES

- Increased bearing load capability
- Integrated load cell
- Modular design
- Shock load up to 2,000,000 Nm
- Oil expansion tank & oil level switch

4

FLOTATION

Flotation cells mainly consist of big tanks where an impeller keeps the water/material solution rotating at a high speed. For this application, Bonfiglioli provides helical bevel or parallel shaft gearmotors with more bearings. Output configurations are usually reinforced bearings to withstand the machine impeller on the shaft. In some models, the machine requires injection of high-pressure air to maximize separation of the material from water.

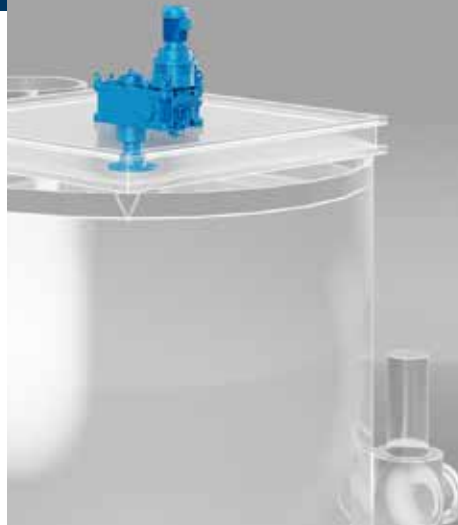

HDP Series

Floatation drives

BENEFITS

- Air flow inlet and through-hole prearrangement on output shaft
- Enhanced oil leak protection
- High radial & axial load capability on output shaft
- Extended life & reliability
- Highly transmissible power

FEATURES

- Reinforced bearing and extended span on output shaft
- Drywell
- Modular design
- Integrated forced oil lubrication
- Control sensors available as an option

Our worldwide presence

Thanks to an international network of closely interconnected commercial and production sites, we can guarantee the same high standards of Bonfiglioli quality anywhere at any given time. We know that our direct presence in local markets is the key to long-lasting success, so our family includes 17 production sites, 23 commercial sites and more than 550 distributors around the world.

Our organization is always close by, offering complete and efficient solutions and supporting our customers with dedicated services, co-engineering and after-sales assistance.

17  PRODUCTION SITES

23  COMMERCIAL SITES

80  COUNTRIES

550  DISTRIBUTORS

~5,000  PEOPLE

Bonfiglioli global locations

AUSTRALIA

Bonfiglioli Transmission (Aust.) Pty Ltd
Plumpton NSW



BRAZIL

Bonfiglioli Redutores do Brasil Ltda
São Bernardo do Campo - São Paulo



CHINA

Bonfiglioli Drives (Shanghai) Co. Ltd.
Shanghai



Selcom Electronics (Shanghai) Co., Ltd

Shanghai



Shanghai



FRANCE

Bonfiglioli Transmission S.A.S.

Marly la Ville



GERMANY

Bonfiglioli Deutschland GmbH

Neuss



Bonfiglioli Deutschland GmbH

Krefeld



O&K Antriebstechnik GmbH

Hattingen



INDIA

Bonfiglioli Transmission Ltd.

Mobility & Wind Industries

Thirumudivakkam

Kancheepuram - Tamil Nadu



Industry & Automation Solutions

Mannur Village, Sriperumbudur Taluk

Kancheepuram - Tamil Nadu



Industry & Automation Solutions

Pune - Maharashtra



ITALY

Bonfiglioli Riduttori S.p.A.

Industry & Automation Solutions

Calderara di Reno (BO)



Industry & Automation Solutions

Carpiano



Mobility & Wind Industries

Forlì



Industry & Automation Solutions

Rovereto



Selcom Group S.p.A.

Castel Maggiore (BO)



Castel Maggiore (BO)



Cadriano (BO)



NEW ZEALAND

Bonfiglioli Transmission (Aust.) Pty Ltd

Auckland - Ellerslie



SINGAPORE

Bonfiglioli South East Asia Pte Ltd

Singapore



SLOVAKIA

Bonfiglioli Slovakia s.r.o.

Považská Bystrica



SOUTH AFRICA

Bonfiglioli South Africa Pty Ltd.

Johannesburg



SPAIN

Tecnotrans Bonfiglioli S.A

Castellbisbal - Barcelona



TURKEY

Bonfiglioli Türkiye Jsc

Çiğli - Izmir



UNITED KINGDOM

Bonfiglioli UK Ltd.

Warrington - Cheshire

Tel. +44 1925 852667



USA

Bonfiglioli USA Inc.

Hebron - Kentucky



VIETNAM

Bonfiglioli Vietnam Co. Ltd.

Ben Cat city, Binh Duong province





We have a relentless commitment to excellence, innovation & sustainability. Our team creates, distributes and services world-class power transmission & drive solutions to keep the world in motion.

HEADQUARTERS

Bonfiglioli S.p.A

Via Cav. Clementino Bonfiglioli, 1
40012 Calderara di Reno - Bologna (Italy)
Tel. +39 051 6473111

