



Solutions for
RECYCLING

 **Bonfiglioli**



CONTENTS

Solutions for

STAND ALONE RECYCLING MACHINE 6

Reverse Vending Machine 8

Stand alone shredder 9

RECYCLING PLANT 10

Primary shredding 12

Secondary shredding 13

Conveying 14

Compactors 15

COMPLETE SOLUTIONS FOR POWER TRANSMISSION & AUTOMATION 16

OUR GLOBAL PRESENCE 18

Engineering Sustainability



WWW.BONFIGLIOLI.COM

RECYCLING



THE WIDEST RANGE OF SOLUTIONS FOR RECYCLING PROCESSING AND MACHINERY

Bonfiglioli conceives, designs and produces custom solutions for collection, downsizing and sorting of waste materials. Recycling is a key component of waste management to reduce pollution and landfill waste.

Our wide product portfolio includes planetary gearboxes, motors and frequency inverters designed according to our customers' specific requirements.

These solutions are developed with the highest level customization, which requires, right from the initial design phases, in-depth interaction between the customer and Bonfiglioli's team, to ensure that all the required specifications and variants are known, and obtain a product that perfectly meets expectations.

This is why our pre-sales and after-sales teams - spread strategically over all continents - play such a crucial role, and why ensuring complete support is at the heart of our global success.



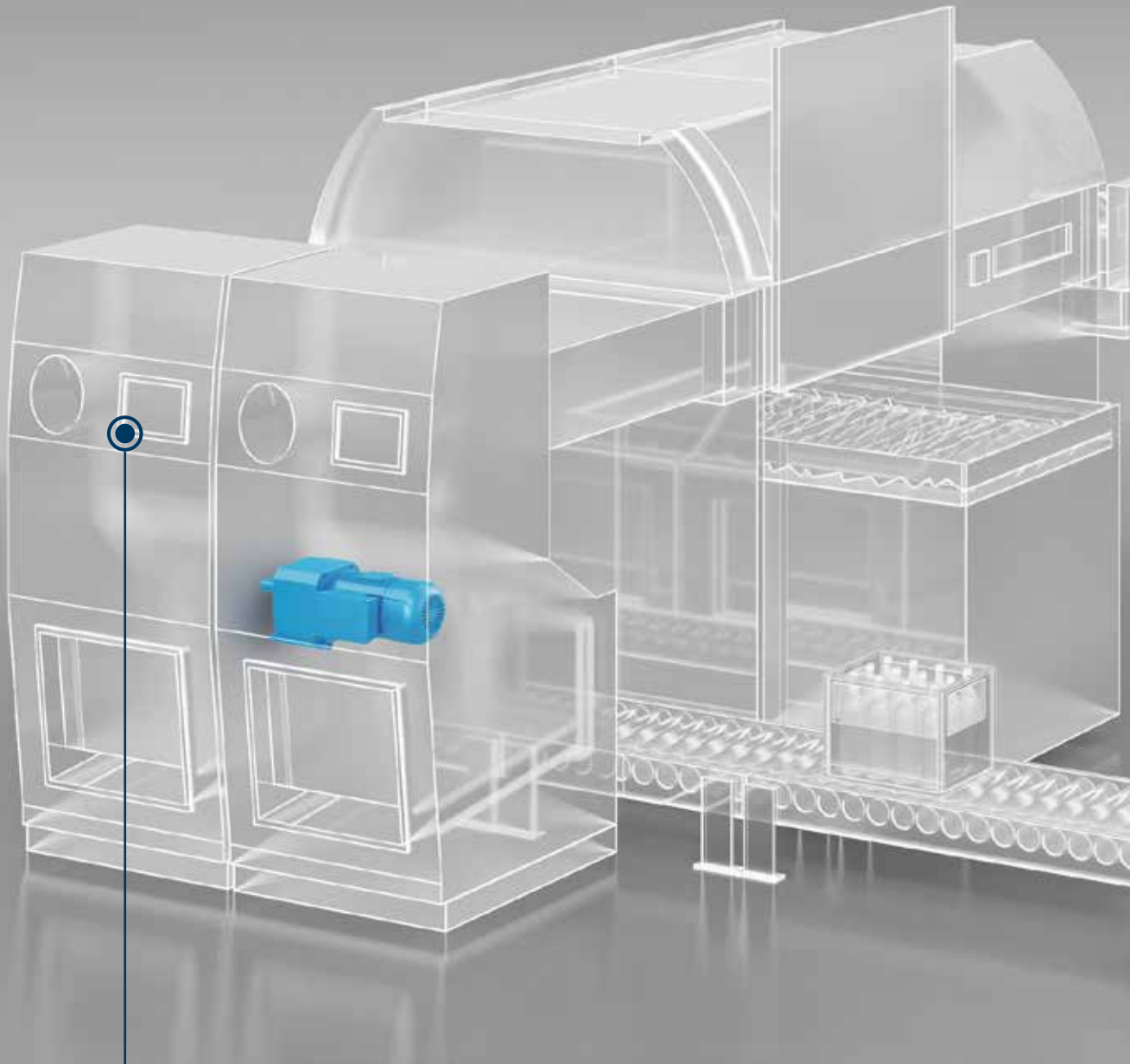

1 **REVERSE VENDING MACHINE**
(SHREDDING OR COMPACTOR)

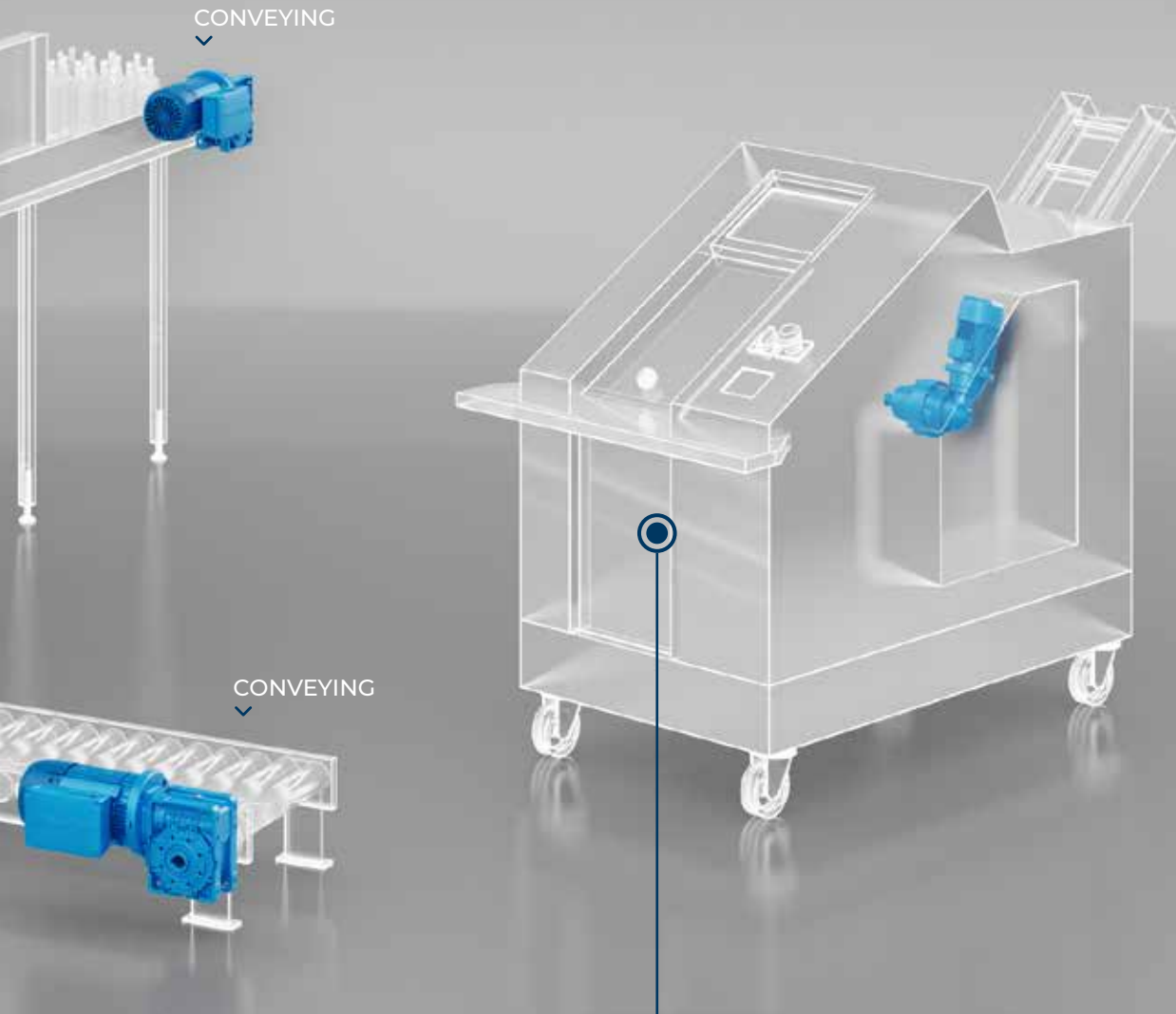

2 STAND ALONE SHREDDERS

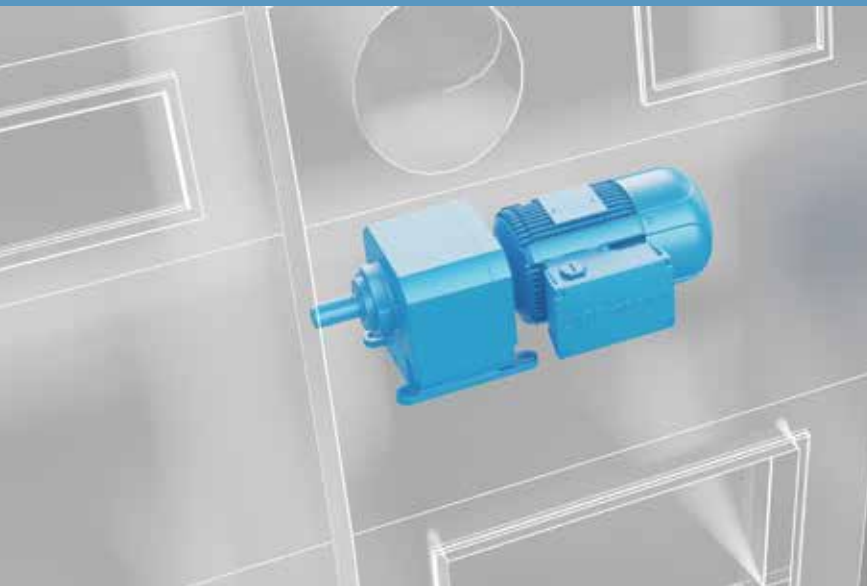

1

REVERSE VENDING MACHINE (SHREDDING OR COMPACTOR)



High reliability and long operating life are the basic features that our products offer for standalone recycling machines. And full integration with Bonfiglioli drives offers a complete package solution.



EVOX CP series

Helical in-line gearbox and geared motor

- Compact gearmotor design
- High shock load resistance
- One-stop-shop for complete drive solutions
- Wash down capability



W series

Universal worm geared motor

- Quiet operation
- Compact gearmotor design
- Universal mounting



AxiaAgile Series

Advanced inverter

- Smooth start
- Variable "cut position" for smaller particles

BENEFITS

FEATURES

- Surface protection
- Universal motor voltage (BXN/MXN)
- High and premium efficiency motors (IE2, IE3)
- Protection rating up to IP56
- Total quality inspection certificate

- Lightweight gearbox
- Universal motor voltage (BXN/MXN)
- High and premium efficiency motors (IE2, IE3)
- Total quality inspection certificate

- CAN open support (variant depending)
- Industrial Ethernet support (variant depending)
- Sensorless control of synchronous, synchronous-reluctance and asynchronous motors
- DC link connection
- Integrated brake chopper
- Power failure control
- Programmable PI Controller
- Integrated PLC (variant-dependent)
- Master/slave function with electronic gear
- Integrated safe torque off STO (SIL 3 / PL e / Cat.3) function
- Intelligent current limits
- Output frequency 0...599 Hz, higher frequencies on request
- Diagnosis and setup via optional keypad and Service interface for PC connection

2

STAND ALONE SHREDDER



High reliability and long operating life are the basic features that our products offer for standalone recycling machines. And full integration with Bonfiglioli drives offers a complete package solution.



300M series Planetary gearbox and geared motor

- High shock load resistance
- Compact design
- One-stop-shop for complete drive solutions
- Wash down capability



AxiaAgile Series Advanced inverter

- Smooth start
- Variable "cut position" for smaller particles

BENEFITS

FEATURES

- High and premium efficiency motors (IE2, IE3)
- Protection rating up to IP56
- Thermal protection (bi-metallic, PTC or KTY)
- Anti-condensation heaters
- Total quality inspection certificate

- CAN open support (variant depending)
- Industrial Ethernet support (variant depending)
- Sensorless control of synchronous, synchronous-reluctance and asynchronous motors
- DC link connection
- Integrated brake chopper
- Power failure control
- Programmable PI Controller
- Integrated PLC (variant-dependng)
- Master/slave function with electronic gear
- Integrated safe torque off STO (SIL 3 / PL e / Cat.3) function
- Intelligent current limits
- Output frequency 0...599 Hz, higher frequencies on request
- Diagnosis and setup via optional keypad and Service interface for PC connection

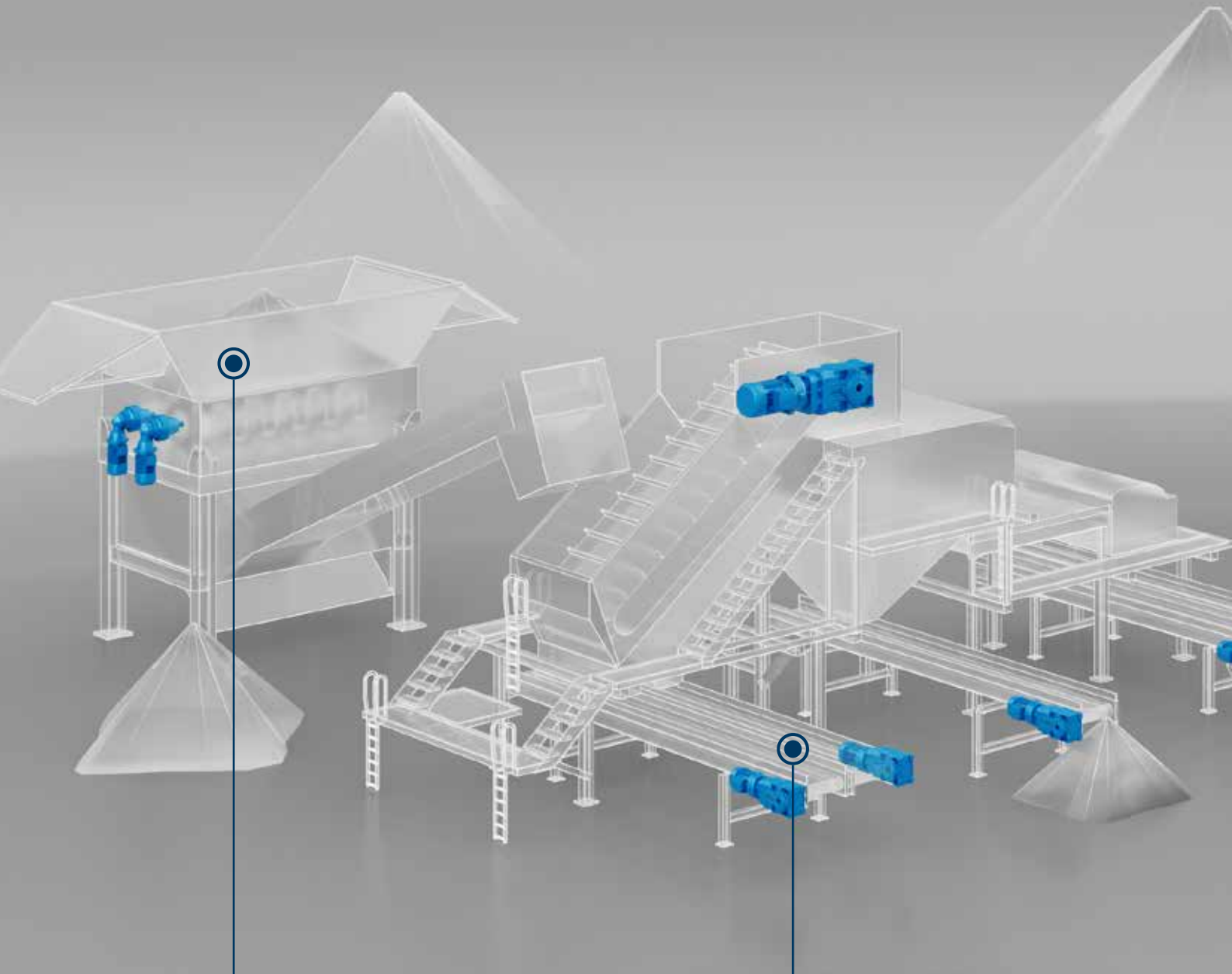

2 SECONDARY SHREDDING

3 CONVEYING

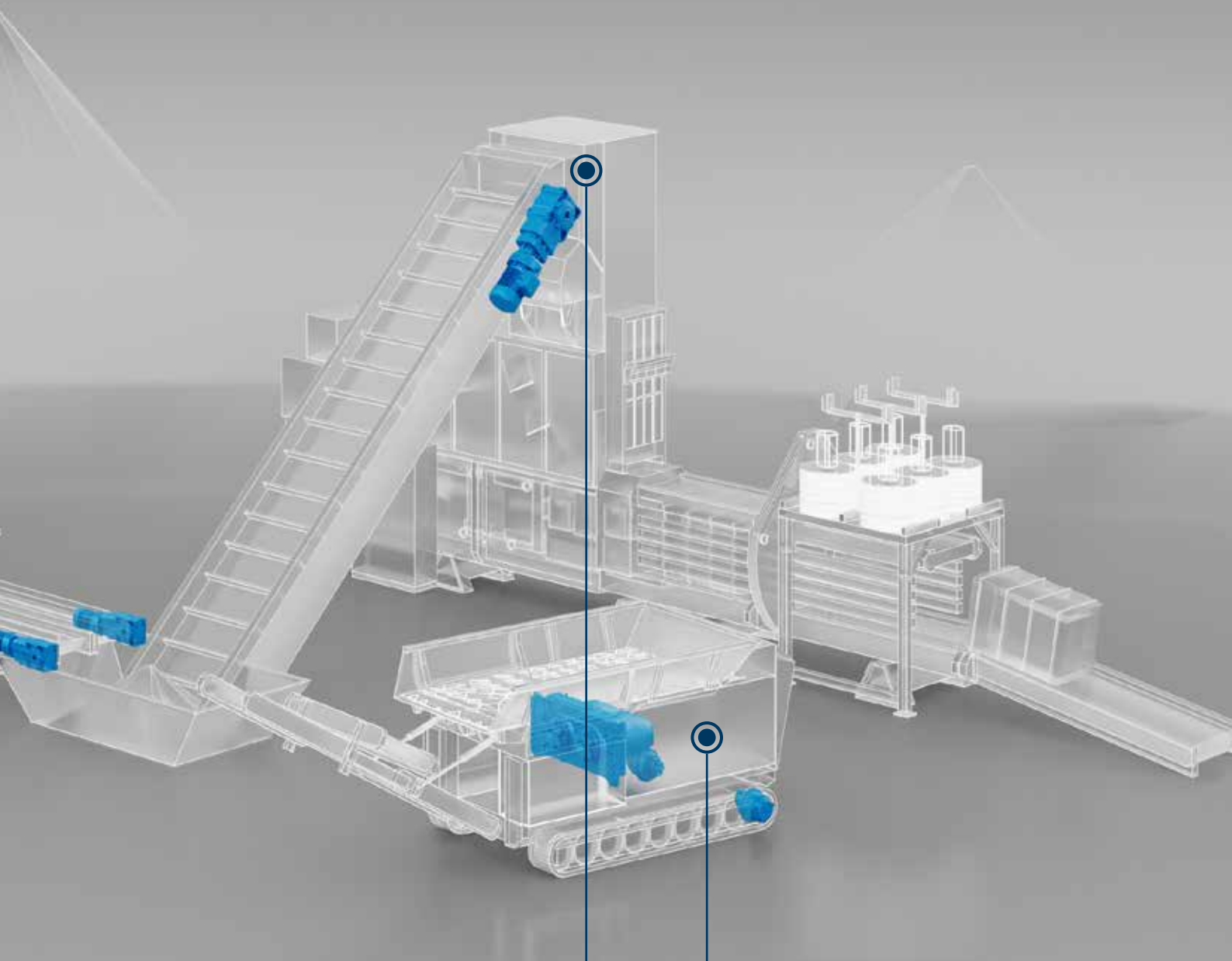

1 PRIMARY SHREDDING

4 COMPACTORS

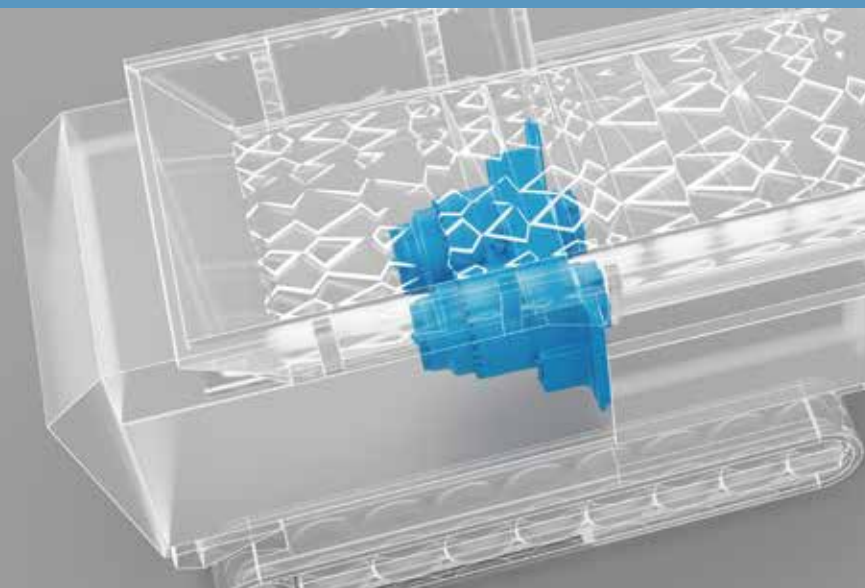

1

PRIMARY SHREDDING

Totally integrated machine design and performance are the key features that our planetary products offer for primary shredding equipment. Bonfiglioli can boast a long experience with all OEM WW leaders. Its dedicated factory provides premium services worldwide.



R3 series

Double planetary gearbox



Active Cube series

Premium inverter

BENEFITS

- Easy installation
- Quiet operation
- High torque capabilities

- Synchronous and asynchronous motor control with or without encoder
- Electronic block detection
- Maximum torque for the entire speed range
- Boost of cinematic energy by speed increase
- 400kW single device with 180% overload
- Air- and water-cooled
- Cabinet solution available

FEATURES

- Class C3, C4 and C5 surface protection (according to standard UNI EN ISO 12944-2)
- Peak torque from 80,000 to 129,000 Nm
- Gear ratios from 92 to 115
- Shamrock output, output shaft: flanged output shaft
- Flanged axial piston hydraulic motors
- Axial piston hydraulic motors
- Synchro drive

- Series optionally extendable for field bus communication and encoder evaluation
- Plug-in power terminals (up to 3kW)
- Plug-in and programmable control terminals
- DC link connection
- Integrated brake chopper
- Positioning function via field bus (motion control compatible to CiA DS402)
- Integrated VPLC
- Electronic gear in speed or position control
- Power failure management
- Integrated Safe Torque Off STO (SIL 3 / PL e) function
- Output frequency 0...599 Hz, higher frequencies on request
- Diagnosis and setup via optional keypad or PC software

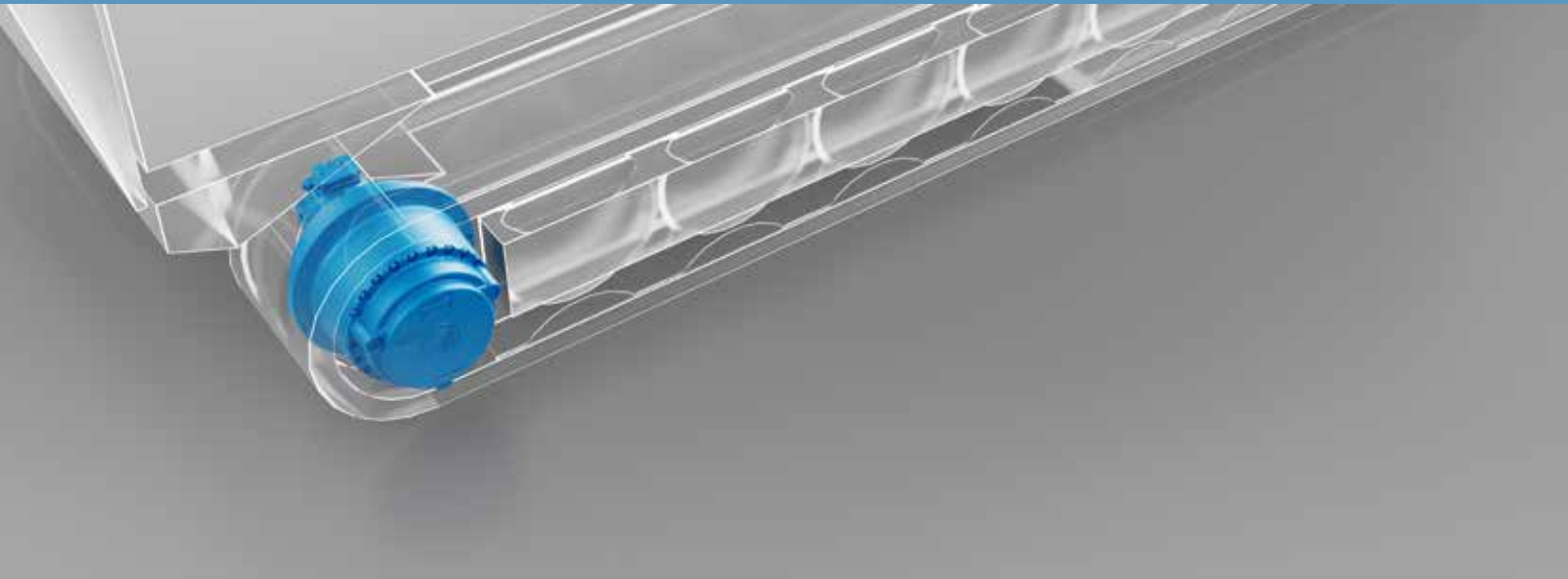

700C Series

Track Drives



BENEFITS

- Safe & efficient solutions
- Compact design

FEATURES

- Rotating housing
- Lifelong mechanical seals on request
- Multiple ratios
- Integrated disc-brake

TECHNICAL DATA

	Torque (Nm)
706 C	26.000
707 C	40.000
709 C	45.000
710 C	50.000
711 C	62.000
713 C	85.000
715 C	130.000
716 C	150.000
717 C	180.000
718 C	240.000
720 C	



700CE Series

Track Drives



Benefits for OEMs

- Ability to downsize and downspeed combustion engines
- Easy installation: electric solution dimensions comparable to standard hydrostatics
- Greater system reliability: fewer mechanical parts
- Virtually maintenance-free electric motors

- From sprocket to electric wire with only one supplier

Benefits for end-users

- Reduced fuel consumption
- Increased productivity
- Better machine maneuverability
- The electric solution is cleaner: lower risk of oil spills

- Gear ratios up to 166
- Input speed up to 6,000 rpm
- Multistage planetary gearbox
- Rotating housing output
- Validated in the field

- Permanent magnet motors
- Suitable for 400 - 700Vdc batteries
- Liquid-cooled
- Aluminum or cast iron housing
- Protection rating >IP67

	Torque (Nm)
707 CE	40.000
709 CE	45.000
710 CE	50.000
711 CE	62.000
713 CE	85.000

	Power S1 (kW)
BPM 200-L1	5
BPM 200-L2	8
BPM 200-L3	11
BPM 200-L4	16
BPM 240-L4	30
BPM 240-L7	46
BPM 300-L8	110





2

SECONDARY SHREDDING

Planetary rating torque over 2 MioNm guarantees a complete range of shredding machine applications. Thanks to their high peak load capacity, our planetary gears are the best in class in terms of mechanical performances. And full integration with Bonfiglioli drives offers a complete package solution.



300M series

Planetary gearbox and geared motor

- High shock load resistance
- Compact design
- One-stop-shop for complete drive solutions
- Reliable and customized solution for extreme low temperature working conditions
- Wash down capability



HDO series

Helical in-line gearbox and geared motor

- High torque capabilities
- High shock load resistance
- Superior mechanical performances



Active Cube series

Premium inverter

- Power range up to 1,200kW
- Reversing in case of block detection
- Reduction of starting current and energy provision

BENEFITS

FEATURES

- High and premium efficiency motors (IE2, IE3)
- Protection rating up to IP56
- Thermal protection (bi-metallic, PTC or KTY)
- Anti-condensation heaters
- Total quality inspection certificate

- Surface protection
- Universal motor voltage (BXN/MXN)
- High and premium efficiency motors (IE2, IE3)
- Total quality inspection certificate

- Series optionally extendable for field bus communication and encoder evaluation
- Plug-in power terminals (up to 3kW)
- Plug-in and programmable control terminals
- DC link connection
- Integrated brake chopper
- Positioning function via field bus (motion control compatible to CiA DS402)
- Integrated VPLC
- Electronic gear in speed or position control
- Power failure management
- Integrated Safe Torque Off STO (SIL 3 / PL e) function
- Output frequency 0...599 Hz, higher frequencies on request
- Diagnosis and setup via optional keypad or PC software

3

CONVEYING

Thanks to the extensive selection of features and space efficiency, we can offer specific products based on the conveying systems. High dynamic response and energy savings are fundamental features when you choose Bonfiglioli. Furthermore, the cost effective and extended service intervals reward a very low cost of ownership. And full integration with Bonfiglioli drives offers a complete package solution.

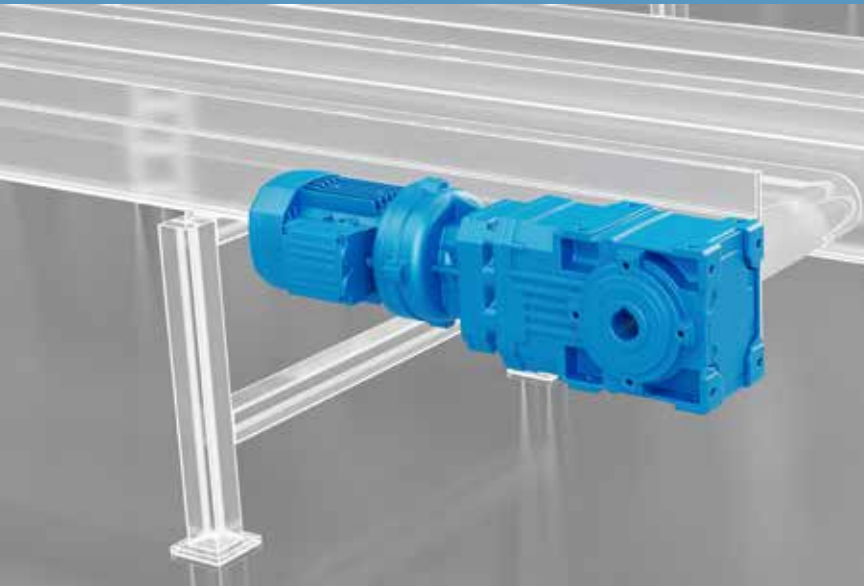

A series

Helical bevel gearmotors

BENEFITS

- Compact
- Universal mounting
- Modular design
- Wash down capability

FEATURES

- Keyed hollow shaft (metric and inch series)
- High and premium efficiency motors (IE2, IE3)
- Wide range of feedback devices (incremental and absolute encoders)



AxiaVert series

Premium drive

- Power range up to 15 kW (up to 200 kW in preparation)
- Reversing in case of block detection

- Series optionally extendable for field bus communication and encoder evaluation
- Plug-in power terminals (up to 3kW)
- Plug-in and programmable control terminals
- DC link connection
- Integrated brake chopper
- Positioning function via field bus (motion control compatible to CiA DS402)
- Optional integrated PLC (IEC61131)
- Electronic gear in speed or position control
- Power failure management
- Functional Safety up to SIL 3 / PL e / Cat. 4 with STO, SBC, SS1, SLS and more
- Output frequency 0...599 Hz, higher frequencies on request
- Diagnosis and setup via optional keypad or PC software

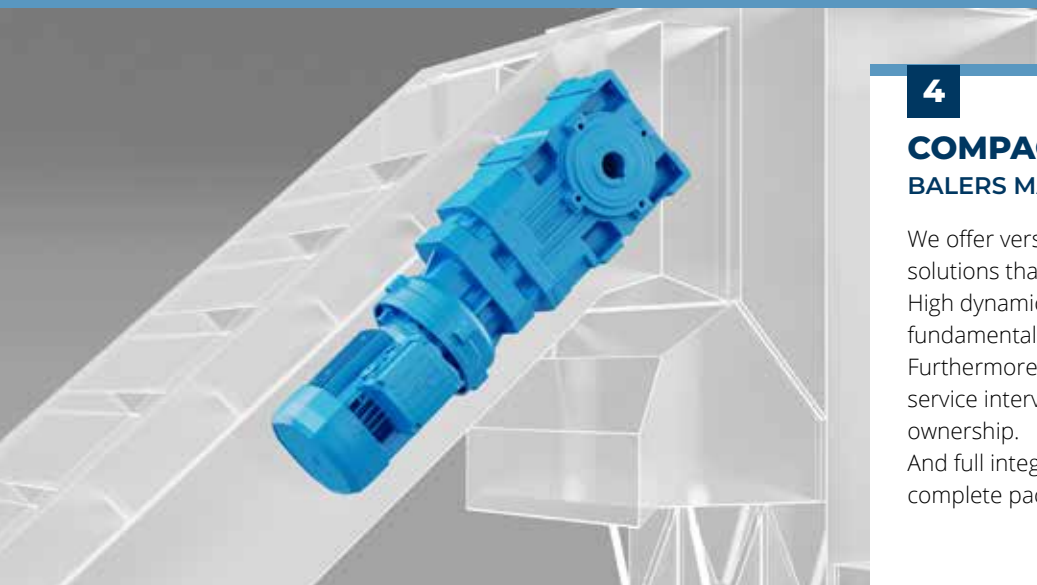

4

**COMPACTORS
BALERS MACHINE**

We offer versatile, robust and energy-efficient solutions that enhance compactor requirements. High dynamic response and energy savings are fundamental features when you choose Bonfiglioli. Furthermore, the cost effective and extended service intervals reward a very low cost of ownership. And full integration with Bonfiglioli drives offers a complete package solution.



A series
Helical bevel gearmotors



AxiaVert series
Premium drive

BENEFITS

- Compact
- Universal mounting
- Modular design
- Wash down capability

- Power range up to 15 kW (up to 200 kW in preparation)
- Reversing in case of block detection

FEATURES

- Keyed hollow shaft (metric and inch series)
- High and premium efficiency motors (IE2, IE3)
- Wide range of feedback devices (incremental and absolute encoders)

- Series optionally extendable for field bus communication and encoder evaluation
- Plug-in power terminals (up to 3kW)
- Plug-in and programmable control terminals
- DC link connection
- Integrated brake chopper
- Positioning function via field bus (motion control compatible to CiA DS402)
- Optional integrated PLC (IEC61131)
- Electronic gear in speed or position control
- Power failure management
- Functional Safety up to SIL 3 / PL e / Cat. 4 with STO, SBC, SS1, SLS and more
- Output frequency 0...599 Hz, higher frequencies on request
- Diagnosis and setup via optional keypad or PC software



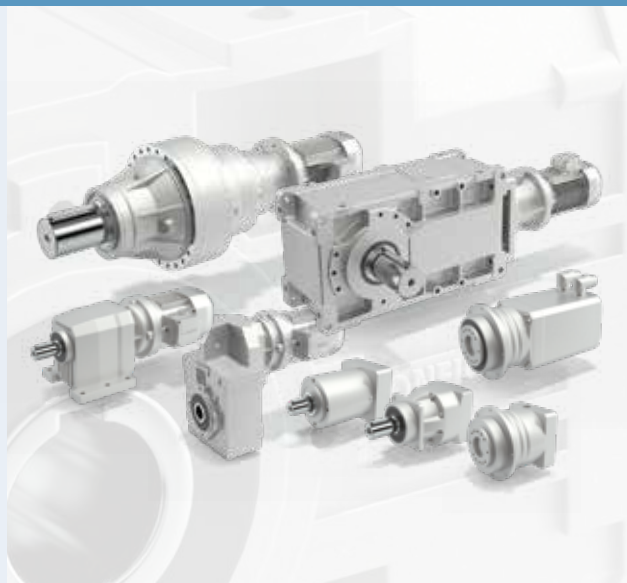

GEARBOXES & GEARED MOTORS

HEAVY DUTY

Heavy duty parallel/right angle shaft geared motors
HDP/HDO Series

- Torque range: 5,190 to 210,000 Nm
- Gear ratios: 5.6 to 500

Planetary geared motors | **300 Series**

- Torque range: 1,250 to 1,287,000 Nm
- Gear ratios: 3.4 ... 2,916

LIGHT DUTY

Worm geared motors | **W/VF Series**

- Torque range: 13 to 7,100 Nm
- Gear ratios: 5.6 to 500

Helical geared motors | **C Series**

- Torque range: 45 to 12,000 Nm
- Gear ratios: 5.6 to 500

Bevel-helical geared motors | **A Series**

- Torque range: 100 to 14,000 Nm
- Gear ratios: 5.6 to 500

Shaft-mounted geared motors | **F Series**

- Torque range: 140 to 14,000 Nm
- Gear ratios: 5.6 to 500

SERVO

Precision planetary servo geared motors
TQ, TQK, TQF, TR, MP, LC, LCK, SL, KR Series

- Torque range: up to 1,000 Nm
- Gear ratios: up to 1,000
- Backlash: lower than 2 and 17 arcmin

MOTORS

Asynchronous IEC motors | **BN, BE, BX Series**

Asynchronous compact motors | **MN, ME, MX series**

A complete range of AC motors, meeting worldwide MEPS (e.g. IE3)

- Power range: 0.06 to 355 kW
- Poles: 4 poles

IE3

Asynchronous motors | **BN, BE, BX, M, ME, MX Series**

A complete range of AC motors, meeting worldwide MEPS (e.g. IE3)

- Power range: 0.06 to 355 kW
- Poles: 4 poles

IE3

Synchronous motors | **BMD Series**

- Stall torque: 0.85 to 60 Nm
- Rated speed: from 1,600 to 6,000 min⁻¹
- Power supply: 230, 400 VAC

Synchronous reluctance motors | **BSR Series**

Two different versions for different needs: High efficiency IE4 and high output

- Power range: 0.37 to 18.5 kW

IE4

Synchronous motors | **BMD, BCR Series**

- Stall torque BMD: 0.85 to 60 Nm
- Stall torque BCR: 0.2 to 115 Nm
- Rated speed BMD: from 1,600 to 6,000 min⁻¹
- Rated speed BCR: from 2,000 to 4,500 min⁻¹
- Power supply: 230, 400 VAC

Synchronous motors with integrated drives | **iBMD Series**

- Stall torque: 2.7 to 36 Nm
- Rated speed: 3,000 min⁻¹
- Power supply: 560 VDC



INVERTERS

HEAVY DUTY

Premium drive | AxiaVert series

- AXV20: 0.25 - 9.2 kW / 230 V 1- or 3-phase
- AXV40: 0.25 - 15 kW / 400 V 3-phase

Premium inverter | Active Cube Series

- ACU210: 0.25 - 9.2 kW / 1- or 3-phase
- ACU410*: 0.25 - 400 kW / 3-phase
- ACU510*: 160 - 400 kW / 3-phase
- ACU610*: 160 - 400 kW / 3-phase 690 V

LIGHT DUTY

Premium drive | AxiaVert series

- AXV20: 0.25 - 9.2 kW / 230 V 1- or 3-phase
- AXV40: 0.25 - 15 kW / 400 V 3-phase

Premium inverter | Active Cube Series

- ACU210: 0.25 - 9.2 kW / 1- or 3-phase
- ACU410*: 0.25 - 400 kW / 3-phase
- ACU510*: 160 - 400 kW / 3-phase
- ACU610*: 160 - 400 kW / 3-phase 690 V

Advanced inverter | AxiaAgile Series

- AXA20: 0.12 - 3 kW / 1-phase | 0.25 - 7.5 kW / 3-phase 230 V
- AXA40: 0.25 - 11 kW / 3-phase 380...480 V

Compact inverter | S2U Series

- S2U230S---(F) IP66: 0.25 - 400 kW / 3-phase

SERVO

Premium drive | AxiaVert series

- AXV20: 0.25 - 9.2 kW / 230 V 1- or 3-phase
- AXV40: 0.25 - 15 kW / 400 V 3-phase

Premium inverter | Active Cube Series

- ACU210: 0.25 - 9.2 kW / 1- or 3-phase
- ACU410*: 0.25 - 400 kW / 3-phase
- ACU510*: 160 - 400 kW / 3-phase
- ACU610*: 160 - 400 kW / 3-phase 690 V

Advanced inverter | AxiaAgile Series

- AXA20: 0.12 - 3 kW / 1-phase | 0.25 - 7.5 kW / 3-phase 230 V
- AXA40: 0.25 - 11 kW / 3-phase 380...480 V

* up to 1200 kW with parallel connection



OUR STRIVING FOR THE FUTURE

DESIGN SIMULATION

Bonfiglioli uses the most advanced **virtual simulation techniques** to accelerate the validation process. This reduces time to market and provides customers with optimized, efficient solutions.



TEST LABORATORIES

In our R&D department we **research, develop, validate and certify** all the products and solutions that are engineered and manufactured in our plants across the world.



CO-ENGINEERING

At Bonfiglioli **we work closely with our customers to satisfy all their needs** and requirements with a truly tailor-made solution.



OUR CONSTANT AMBITION

QUALITY, HEALTH, SAFETY, ENVIRONMENT & ENERGY

QUALITY: WE CARE ABOUT OUR CUSTOMERS

Our team is completely dedicated to continuous improvement in the areas of quality, safety, environmental and energy, throughout the entire value chain, from the smallest supplier to the end customer. Bonfiglioli is committed to achieving the highest quality standards, and our products are intended to generate value for our customers while respecting both people and the environment. We design, manufacture and supply effective products and services that set a benchmark for quality in the industry.

Bonfiglioli management systems are certified ISO 9001:2015, ISO 14001:2015, ISO 45001:2023 and ISO 50001:2018, while our products are covered by 7 international certifications. Responsibility, excellence and continuous improvement are the basic elements that make us the favored partner of our clients and suppliers.

HEALTH & SAFETY: SUSTAINABILITY STARTS WITH SAFETY

Prevention of accidents and incidents is a key element in our company's sustainability strategy and an integral part of every one of our business processes. Successful risk management is essential for protecting our employees and assets, thereby strengthening their contributions.

ENVIRONMENT & ENERGY: RESPECT THE PRESENT TO BUILD THE FUTURE

At Bonfiglioli, we believe that respect for the present and adopting environmental protection and energy efficiency policies are essential if we are to enjoy a better future.

OUR GLOBAL PRESENCE

Thanks to an international network of closely interconnected commercial and production sites, we can guarantee the same high standards of Bonfiglioli quality anywhere at any given time. We know that our direct presence in local markets is the key to long-lasting success, so our family includes 17 production sites, 23 commercial sites and more than 550 distributors around the world.

Our organization is always close by, offering complete and efficient solutions and supporting our customers with dedicated services, co-engineering and after-sales assistance.



17
PRODUCTION SITES



23
COMMERCIAL SITES



80
COUNTRIES



550
DISTRIBUTORS



~5,000
PEOPLE

AUSTRALIA

Bonfiglioli Transmission (Aust.) Pty Ltd

2, Cox Place Glendenning NSW 2761
Locked Bag 1000 Plumpton NSW 2761
Tel. +61 2 8811 8000



BRAZIL

Bonfiglioli Redutores do Brasil Ltda

Av. Osvaldo Fregonezi, 171, cjs 31 e 44
CEP 09851-015 - São Bernardo do Campo
São Paulo
Tel. +55 11 4344 2322



CHINA

Bonfiglioli Drives (Shanghai) Co. Ltd.

#68, Hui-Lian Road, QingPu District,
201707 Shanghai
Tel. +86 21 6700 2000



Selcom Electronics (Shanghai) Co., Ltd

A7, No.5399, Waiqingsong Road, QingPu
District,
201707 Shanghai
Tel. +86 21 6010 8100



A24, No.5399, Waiqingsong Road, QingPu
District,

201707 Shanghai
Tel. +86 21 6010 8100



FRANCE

Bonfiglioli Transmission S.A.S.

14 Rue Eugène Pottier
Zone Industrielle de Moimont II
95670 Marly la Ville
Tel. +33 1 34474510



GERMANY

Bonfiglioli Deutschland GmbH

Sperberweg 12 - 41468 Neuss
Tel. +49 0 2131 2988 0



Bonfiglioli Deutschland GmbH

Europark Fichtenhain B6 - 47807 Krefeld
Tel. +49 0 2151 8396 0



O&K Antriebstechnik GmbH

Ruhrallee 8-12 - 45525 Hattingen
Tel. +49 0 2324 2050 1



INDIA

Bonfiglioli Transmission Ltd.

Mobility & Wind Industries

AC 7 - 11, SIDCO Industrial Estate,
Thirumudivakkam
Kancheepuram - 600132 - Tamil Nadu
Tel. +91 844 844 8649



Industry & Automation Solutions

Survey No. 528/1, Perambakkam High Road
Mannur Village, Sriperumbudur Taluk
Kancheepuram - 602 105 - Tamil Nadu
Tel. +91 844 844 8649



Industry & Automation Solutions

Plot No E-5/2, Badhalwadi
Talegaon MIDC Phase II,
Pune - 410 507 - Maharashtra
Tel. +91 844 844 8649



ITALY

Bonfiglioli Riduttori S.p.A.

Industry & Automation Solutions

Via Cav. Clementino Bonfiglioli, 1
40012 Calderara di Reno
Tel. +39 051 6473111



Industry & Automation Solutions

Via Sandro Pertini, lotto 7b
20080 Carpiano
Tel. +39 02985081



Mobility & Wind Industries

Via Enrico Mattei, 12 Z.I. Villa Selva
47122 Forlì
Tel. +39 0543 789111



Industry & Automation Solutions

Via Unione, 49 - 38068 Rovereto
Tel. +39 0464 443435/36



Selcom Group S.p.A.

Via Achille Grandi, 5
40013 Castel Maggiore (BO)
Tel. +39 051 6387111



Via Marino Serenari, 18

40013 Castel Maggiore (BO)
Tel. +39 051 6387111



Via Cadriano, 19

40057 Cadriano (BO)
Tel. +39 051 6387111



NEW ZEALAND

Bonfiglioli Transmission (Aust.) Pty Ltd

88 Hastie Avenue, Mangere Bridge,
2022 Auckland
PO Box 11795, Ellerslie
Tel. +64 09 634 6441



SINGAPORE

Bonfiglioli South East Asia Pte Ltd

8 Boon Lay Way, #04-09,
8@ Tadehub 21, Singapore 609964
Tel. +65 6268 9869



SLOVAKIA

Bonfiglioli Slovakia s.r.o.

Robotnícka 2129
Považská Bystrica, 01701 Slovakia
Tel. +421 42 430 75 64



SOUTH AFRICA

Bonfiglioli South Africa Pty Ltd.

55 Galaxy Avenue, Linbro Business Park,
Sandton, Johannesburg
2090 South Africa
Tel. +27 11 608 2030



SPAIN

Tecnotrans Bonfiglioli S.A

Avinguda del Ferrocarril, nº 14,
Polígono Industrial Can Estapé
08755 Castellbisbal - Barcelona
Tel. +34 93 447 84 00



TURKEY

Bonfiglioli Türkiye Jsc

Atatürk Organize Sanayi Bölgesi,
10007 Sk. No. 30
Atatürk Organize Sanayi Bölgesi,
35620 Çiğli - Izmir
Tel. +90 0 232 328 22 77



UNITED KINGDOM

Bonfiglioli UK Ltd.

Unit 1 Calver Quay, Calver Road, Winwick
Warrington, Cheshire - WA2 8UD
Tel. +44 1925 852667



USA

Bonfiglioli USA Inc.

3541 Hargrave Drive
Hebron, Kentucky 41048
Tel. +1 859 334 3333



VIETNAM

Bonfiglioli Vietnam Co. Ltd.

Lot C-9D-CN, My Phuoc 3 Industrial Park,
Thoi Hoa ward, Ben Cat city, Binh Duong
province, Vietnam
Tel. +84 274 3577411





We have a relentless commitment to excellence, innovation & sustainability. Our team creates, distributes and services world-class power transmission & drive solutions to keep the world in motion.

HEADQUARTERS

Bonfiglioli S.p.A

Via Cav. Clementino Bonfiglioli, 1
40012 Calderara di Reno - Bologna (Italy)
Tel. +39 051 6473111

