



SOLUTIONS FOR
Textile
Industry





We engineer dreams



Contents

FIBER PREPARATION.....	6
Cleaning & blending.....	8
Carding.....	10
PRESPINNING.....	12
Draw frame (Leveling).....	14
Roving.....	16
SPINNING	18
Rotor Spinning.....	20
Air Spinning.....	22
Ring Spinning.....	24
Winding.....	26
MAN-MADE FIBER.....	28
Synthetic yarn extrusion.....	30
Beaming.....	31
Knitting.....	32
SPECIFIC FUNCTIONS FOR THE TEXTILE SECTOR.....	34
OUR PROJECTION INTO THE FUTURE	36
OUR CONSTANT AMBITION	37
OUR GLOBAL PRESENCE.....	38

Engineering Solutions



WWW.BONFIGLIOLI.COM

Textile Industry

THE WIDEST RANGE OF SOLUTIONS FOR TEXTILE PROCESSING AND MACHINERY

The textile industry is a sector in which fabrics and yarns are manufactured and processed using different techniques and materials.

The sub-sectors include spinning, weaving, knitting, dyeing, printing, and finishing. Each sector requires specific equipment and techniques to produce the desired fabric or textile product.

A wide range of natural and synthetic fibers such as cotton, wool, silk, polyester, and nylon are used to produce fabrics and yarns, which in turn are processed into products.

The industry is constantly evolving its technologies and techniques to improve efficiency, sustainability, and product quality. Advanced manufacturing processes are also used to develop environmentally friendly materials and production methods in compliance with local and international regulations. This constant evolution fosters a culture of continuous improvement by investing in research and development and by adopting technologies and processes to emerging trends.



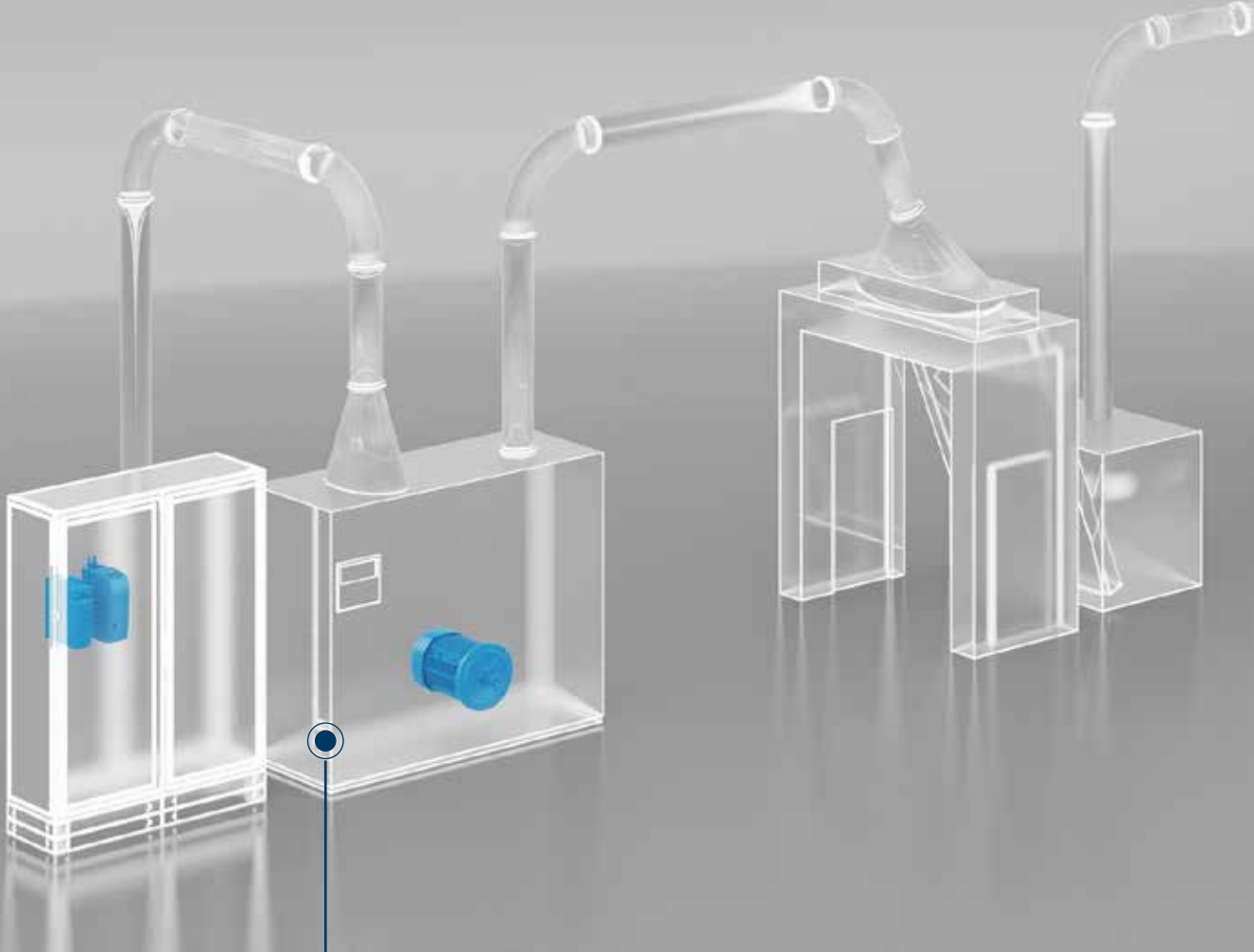

1 CLEANING & BLENDING

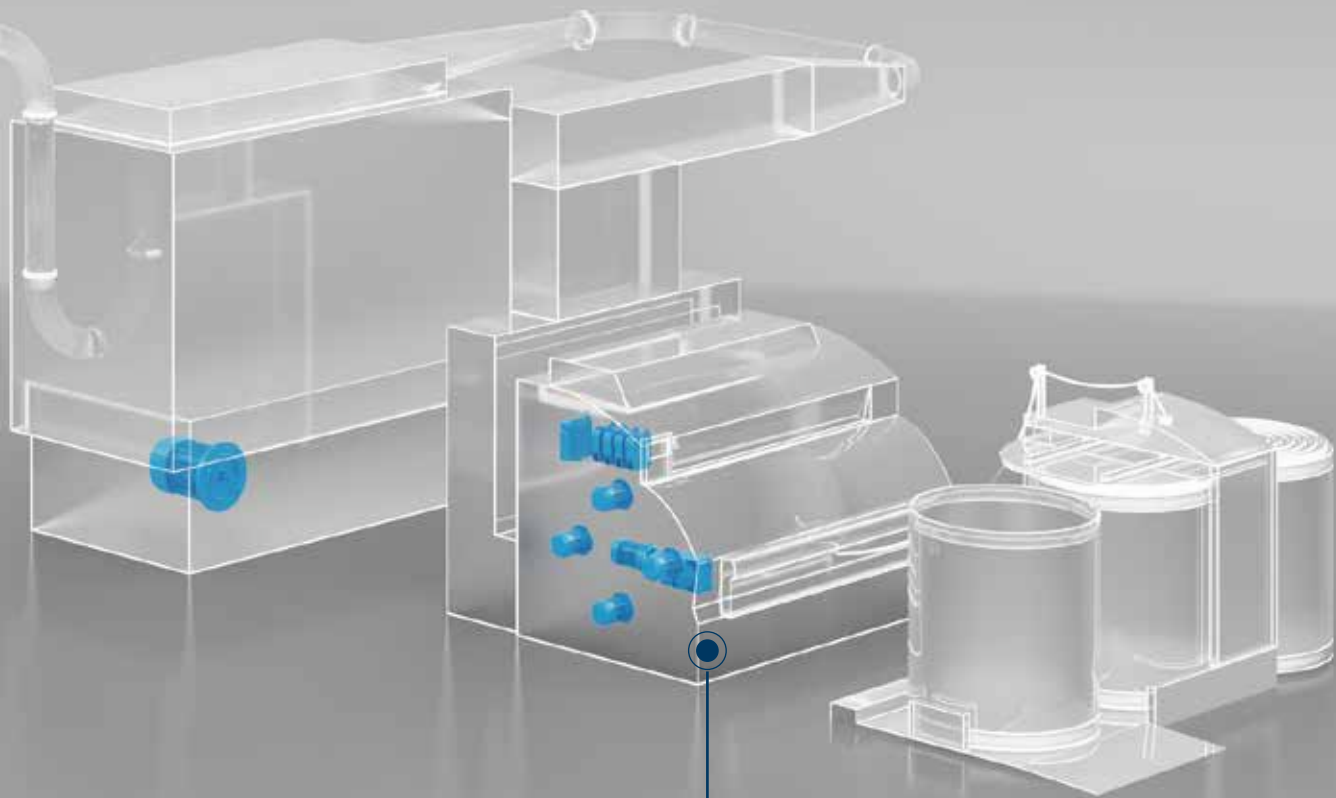

2 CARDING

1

CLEANING & BLENDING

The blow room, which is the first stage in the processing of raw cotton, wool, or other fibers in the textile industry, is responsible for opening, cleaning and blending the fibers to prepare them for further processing in several stages.

The cleaning and blending process in the blow room is crucial for ensuring that the fibers are clean and uniform before further processing. Any impurities or inconsistencies in the fibers can negatively impact the quality of the finished product. Therefore, blowroom machines are designed to be efficient and effective in removing impurities and creating a uniform blend of fibers.

The fibers are fed into a machine called an opener, which uses spiked rollers to open the compressed fibers and remove any dirt, dust, or impurities. Afterwards the opened fibers are passed through a machine called a cleaner, which uses a combination of air currents and screens to remove any remaining impurities. Then, the cleaned fibers will be blended to create a uniform mixture using air currents and mechanical processes. The blended fibers will be fed into a carding machine, which further opens and aligns the fibers to create a web that is known as carded sliver.

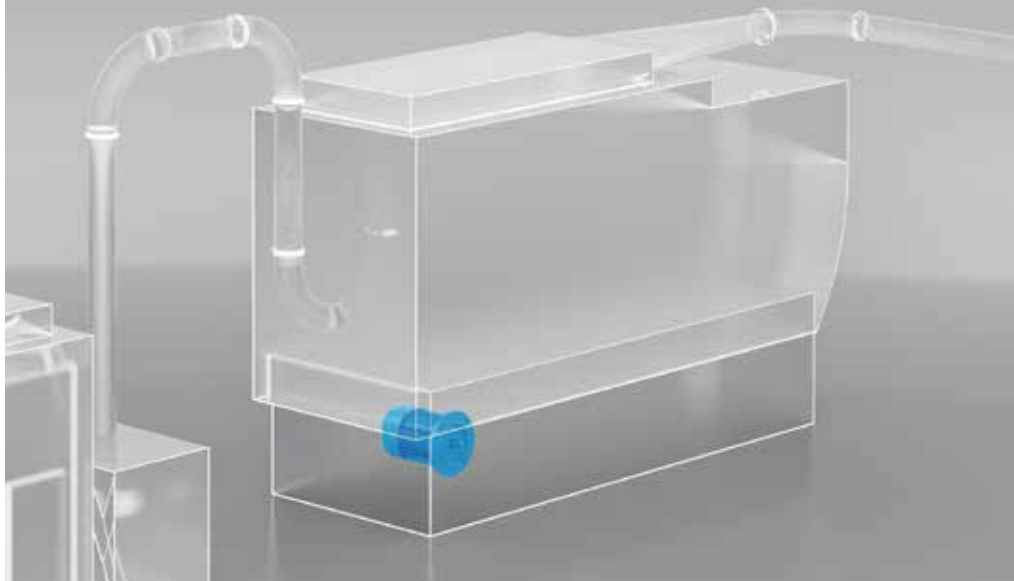

BSR Series Synchronous Reluctance Motors

BENEFITS

- High dynamic capability
- Economic PM-servo replacement
- Reduced total cost of ownership (TCO)
- Adaptable to industrial gearboxes thanks to IEC design

FEATURES

- High energy efficiency of the drive system class up to IES2
- Motor efficiency class up to IE4
- Eco-friendly
- Two packages available: High Efficiency and High Output
- Power range: 0.37 to 18.5 kW
- Low rotor inertia
- Low heat dissipation
- High speed range: 0 to 4500 rpm (max)
- High torque at zero speed
- High Output motors have a reduced frame up to two sizes if compared with IM
- Optimized compatibility with Active Cube 410 frequency inverter series
- Effective torque and speed control (also at low speed) without encoder

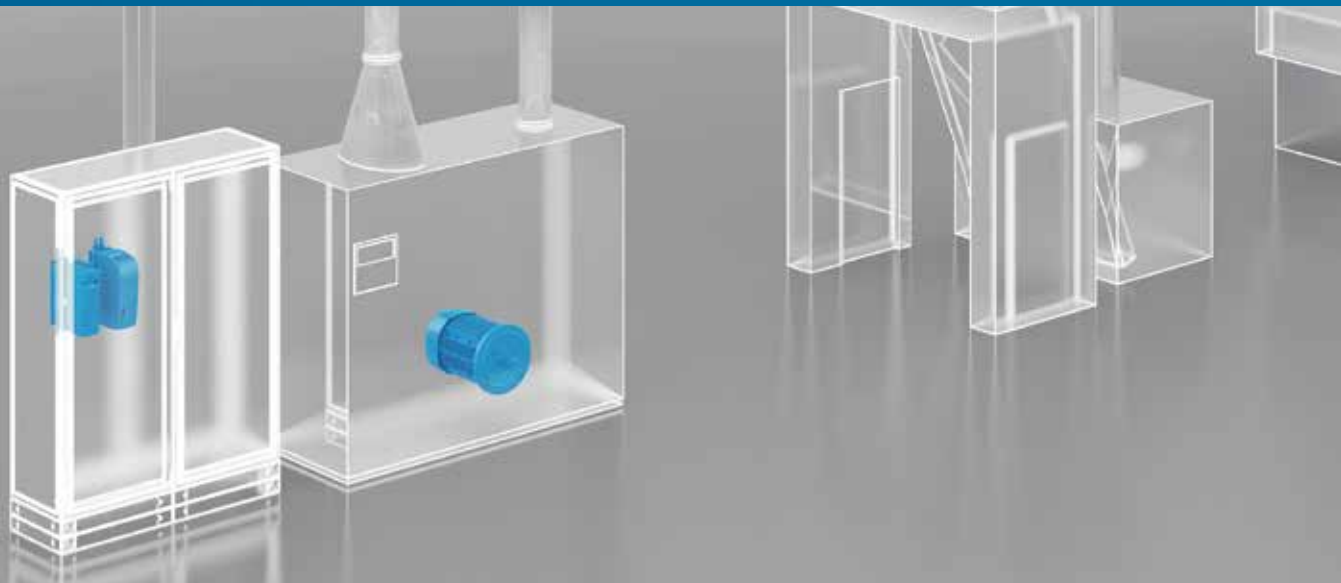

BX Series
Asynchronous IE3 Motors



Agile Series
Smart Inverter



Active Cube Series
Premium inverter

BENEFITS

- Reliability and robustness
- Different options like encoder and mechanical brake

- Low energy consumption
- Flexibility
- Preset values for Bonfiglioli motors to decrease commissioning times
- Very high power density
- Compactness
- Smart mounting to save space into the cabinet

- Modular inverter platform to adapt the inverter to the machine
- Reliable and precise Process control
- Smooth Start and Stop control
- Power failure management with controlled ramp down

FEATURES

- IE3 Efficiency class
- Power range: 0.75 to 22 kW
- Nominal speed range: 0 to 1500 rpm as 4 pole motor

- Series optionally extendable for field bus communication
- Sensorless synchronous and asynchronous motor control
- Modbus and Systembus onboard
- DC link connection
- Integrated brake chopper
- Power failure control
- Programmable PI controller
- Integrated VPLC
- Master/slave function with electronic gear
- Integrated safe torque off STO (SIL 2 / PL d) function
- Energy saving function
- Smart current limits
- Output frequency 0...599 Hz, higher frequencies on request
- Diagnosis and setup via integrated keypad and integrated service interface for PC connection

- Power range: 0.25 to 400 kW
- Speed or Torque Control
- Option modules to include field bus communication and encoder evaluation
- Plug-in power terminals (up to 4 kW)
- Plug-in and programmable control terminals
- DC link connection
- Integrated brake chopper
- Integrated VPLC
- Integrated safe torque off STO (SIL 3 / PL e) function
- Output frequency 0...599 Hz
- Diagnosis and setup via optional keypad or PC software
- Optional Encoder evaluation

2

CARDING

The carding machine is used to process fibers such as cotton, wool, and synthetic fibers into a form that can be spun into yarn. The machine uses a series of rollers and wire-covered cylinders to separate, clean, and align the fibers.

The process starts with the fibers being fed into the machine, where they are opened and separated by a series of rollers. The separated fibers are then passed through a series of wire-covered cylinders called carding drums, which further separate and align the fibers. As the fibers pass through the carding drums, any remaining impurities are removed, resulting in a web of clean, aligned fibers known as carded sliver. Carding machines can be designed to process different quantities of fiber, from small-scale production to large-scale industrial production.

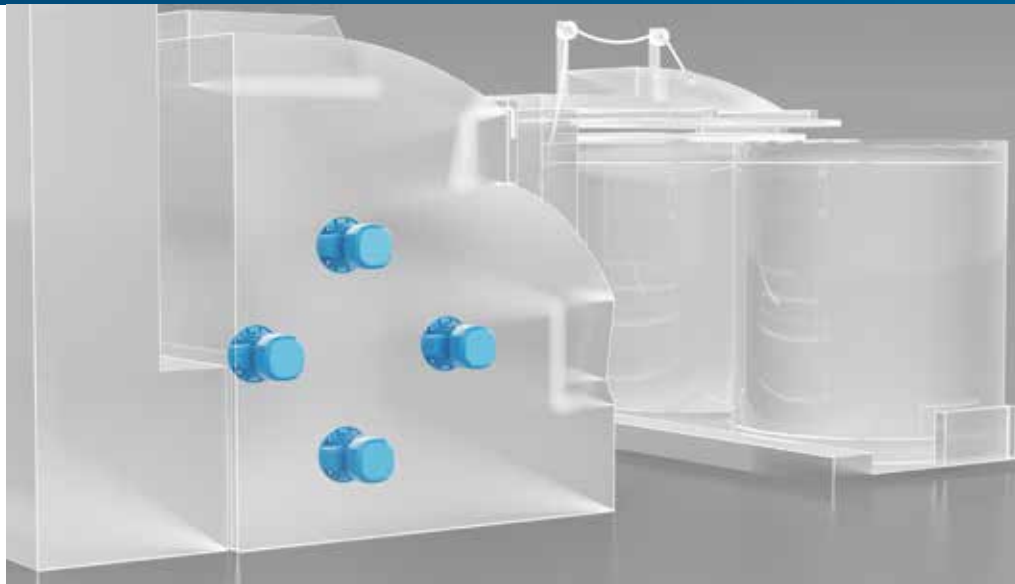

BSR Series Synchronous Reluctance Motors

BENEFITS

- High dynamic capability
- Economic PM-servo replacement
- Reduced total cost of ownership (TCO)
- Adaptable to industrial gearboxes thanks to IEC design

FEATURES

- High energy efficiency of the drive system class up to IES2
- Motor efficiency class up to IE4
- Eco-friendly
- Two packages available: High Efficiency and High Output
- Power range: 0.37 to 18.5 kW
- Low rotor inertia
- Low heat dissipation
- High speed range: 0 to 4500 rpm (max)
- High torque at zero speed
- High Output motors have a reduced frame up to two sizes if compared with IM
- Optimized compatibility with Active Cube 410 frequency inverter series
- Effective torque and speed control (also at low speed) without encoder



A + BSR Series

Helical bevel gearbox with Synchronous Reluctance Motors



Agile Series

Smart Inverter



Active Cube Series

Premium inverter

BENEFITS

- Reduced total cost of ownership (TCO)
- Compactness
- Reliability and robustness
- Modular design

- Low energy consumption
- Flexibility
- Preset values for Bonfiglioli motors to decrease commissioning times
- Very high power density
- Compactness
- Smart mounting to save space into the cabinet

- Modular inverter platform to adapt the inverter to the machine
- Reliable and precise Process control
- Smooth Start and Stop control
- Power failure management with controlled ramp down

FEATURES

- High energy efficiency of the drive system class up to IES2
- Motor efficiency up to IE4
- Effective torque and speed control (also at low speed) without encoder
- Optimized drive package

- Series optionally extendable for field bus communication
- Sensorless synchronous and asynchronous motor control
- Modbus and Systembus onboard
- DC link connection
- Integrated brake chopper
- Power failure control
- Programmable PI controller
- Integrated VPLC
- Master/slave function with electronic gear
- Integrated safe torque off STO (SIL 2 / PLd) function
- Energy saving function
- Smart current limits
- Output frequency 0...599 Hz, higher frequencies on request
- Diagnosis and setup via integrated keypad and integrated service interface for PC connection

- Power range: 0.25 to 400 kW
- Speed or Torque Control
- Option modules to include field bus communication and encoder evaluation
- Plug-in power terminals (up to 4 kW)
- Plug-in and programmable control terminals
- DC link connection
- Integrated brake chopper
- Integrated VPLC
- Integrated safe torque off STO (SIL 3 / PL e) function
- Output frequency 0...599 Hz
- Diagnosis and setup via optional keypad or PC software
- Optional Encoder evaluation



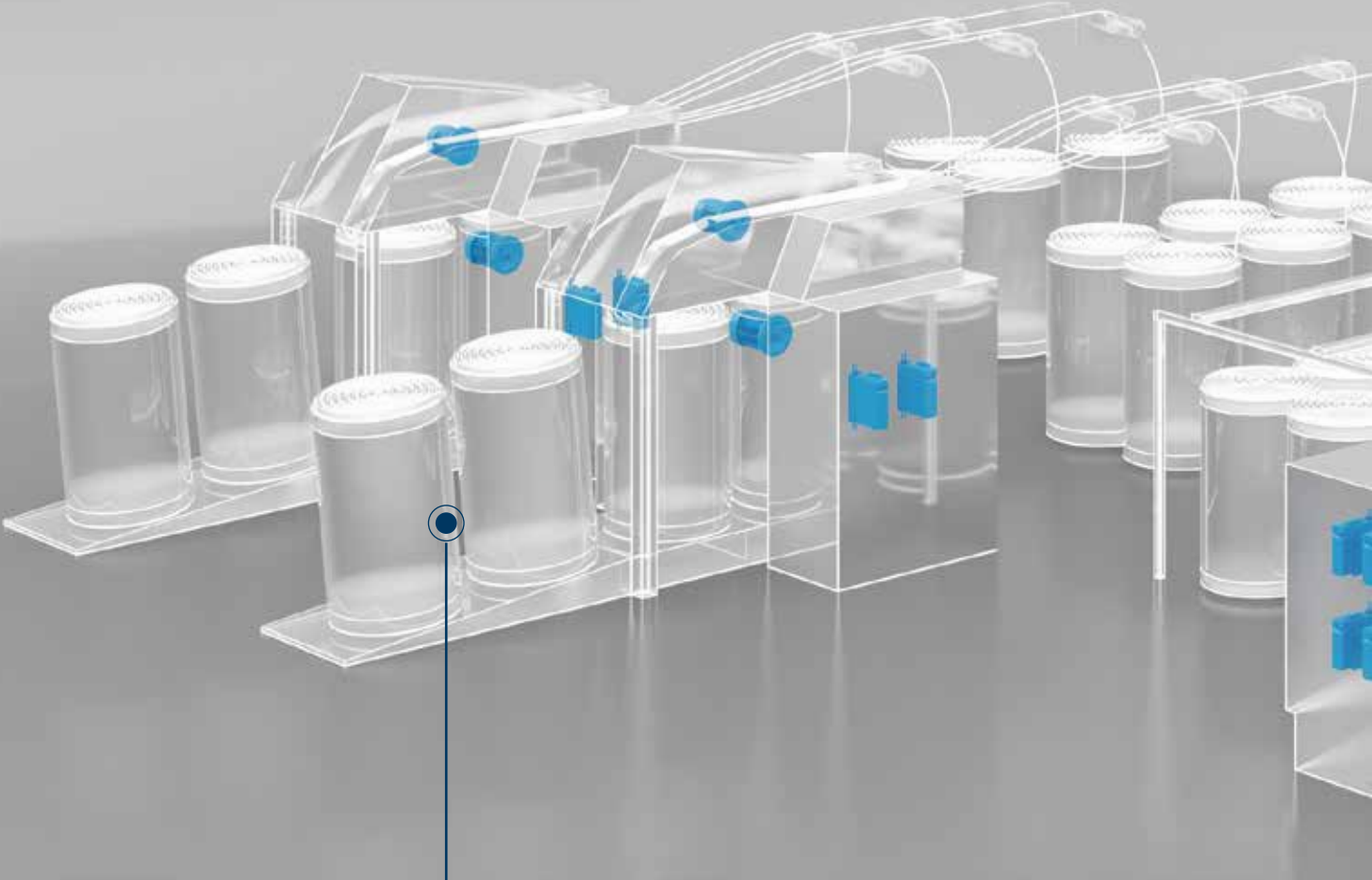

1 DRAW FRAME (LEVELING)

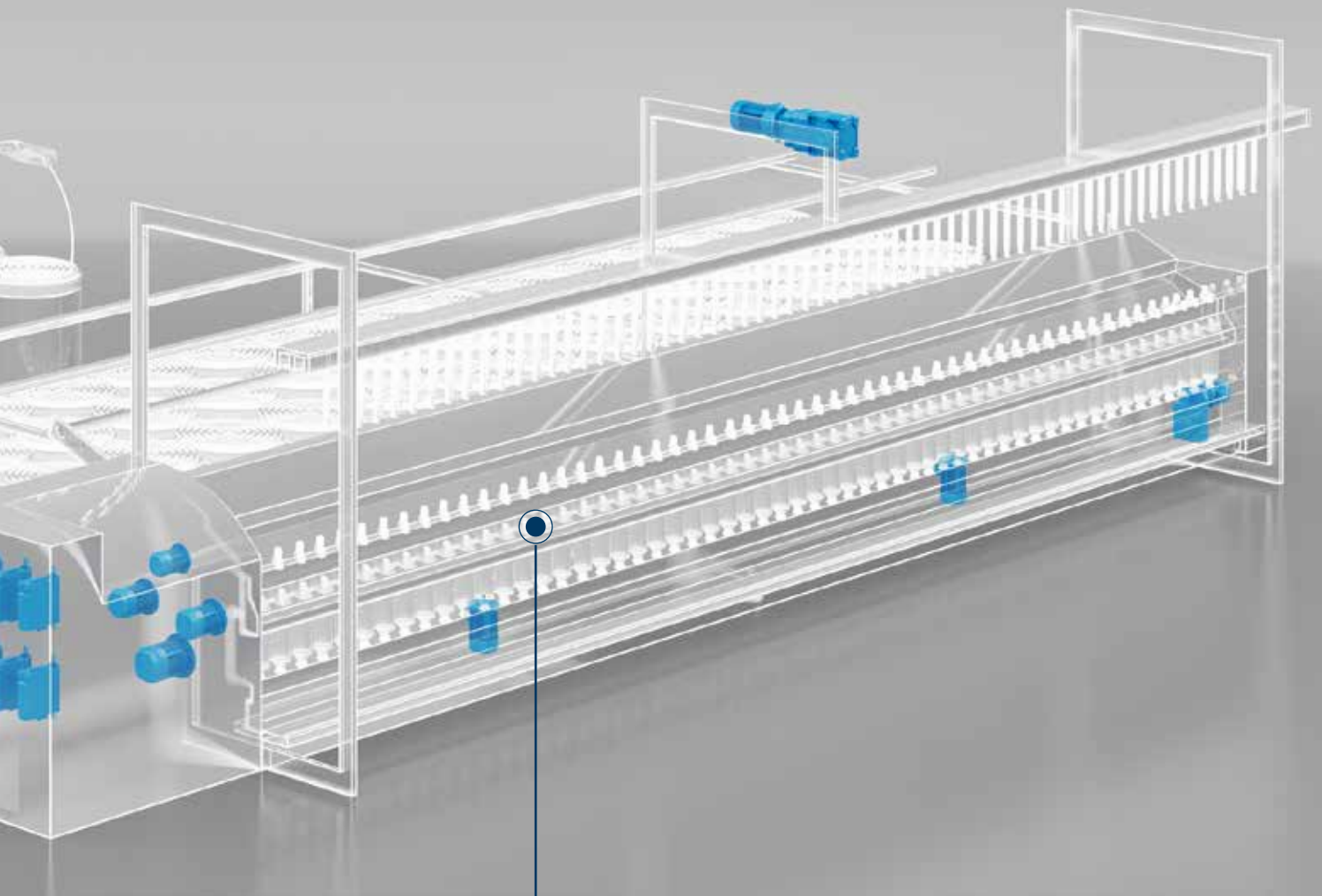

2 ROVING

1

DRAW FRAME (LEVELING)

A draw frame is a machine used in the textile industry for the further processing of the sliver, which is a loosely twisted strand of fibers obtained after carding. The primary function of the draw frame is to improve the quality and uniformity of the sliver before it is spun into yarn. The sliver from the carding machine is fed into the draw frame. The draw frame consists of multiple sets of rollers and drafting systems. The sliver passes to the drafting zones in the draw frame which consists rollers that grip the sliver and stretch it, reducing the sliver's weight and increasing its length. This process is known as drafting, and it helps align the fibers and improve their parallel arrangement.

The draw frame plays a crucial role in the spinning process by improving the sliver's uniformity, reducing variations in fiber length and thickness, and aligning the fibers parallel to each other. This results in a more consistent and higher-quality sliver, which can be further processed in spinning machines to produce yarn. The draw frame is an essential component in textile mills, especially in the production of fine or high-quality yarns, where precise control over sliver properties is crucial for achieving the desired yarn characteristics.

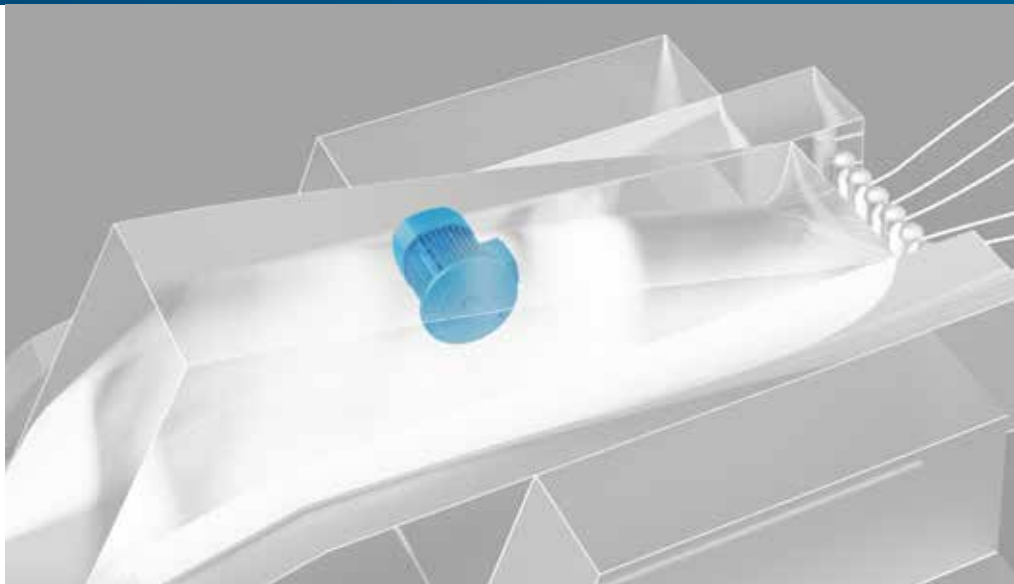

BSR Series Synchronous Reluctance Motors

BENEFITS

- High dynamic capability
- Economic PM-servo replacement
- Reduced total cost of ownership (TCO)
- Adaptable to industrial gearboxes thanks to IEC design

FEATURES

- High energy efficiency of the drive system class up to IES2
- Motor efficiency class up to IE4
- Eco-friendly
- Two packages available: High Efficiency and High Output
- Power range: 0.37 to 18.5 kW
- Low rotor inertia
- Low heat dissipation
- High speed range: 0 to 4500 rpm (max)
- High torque at zero speed
- High Output motors have a reduced frame up to two sizes if compared with IM
- Optimized compatibility with Active Cube 410 frequency inverter series
- Effective torque and speed control (also at low speed) without encoder

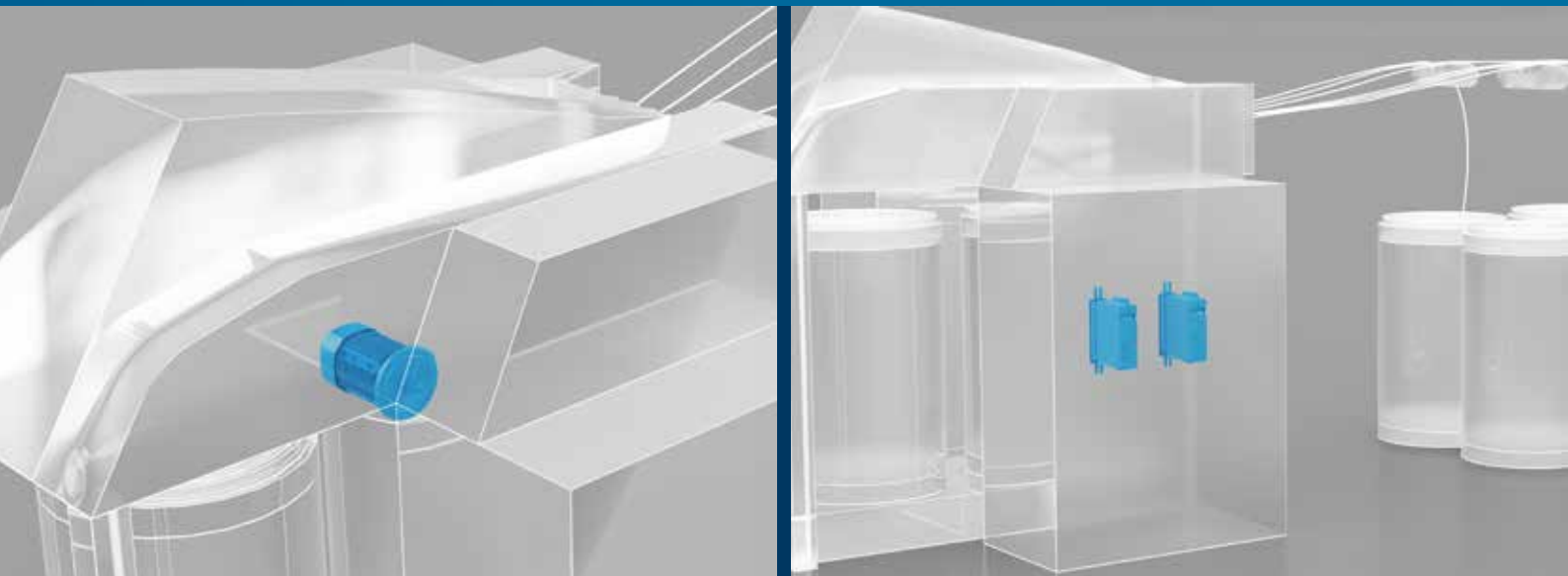

BX Series
Asynchronous IE3 Motors

BENEFITS

- Reliability and robustness
- Different options like encoder and mechanical brake

FEATURES

- IE3 Efficiency class
- Power range: 0.75 to 22 kW
- Nominal speed range: 0 to 1500 rpm as 4 pole motor



Active Cube Series
Premium inverter

- Modular inverter platform to adapt the inverter to the machine
- Reliable and precise Process control
- Smooth Start and Stop control
- Power failure management with controlled ramp down

- Power range: 0.25 to 400 kW
- Speed or Torque Control
- Option modules to include field bus communication and encoder evaluation
- Plug-in power terminals (up to 4 kW)
- Plug-in and programmable control terminals
- DC link connection
- Integrated brake chopper
- Integrated VPLC
- Integrated safe torque off STO (SIL 3 / PL e) function
- Output frequency 0...599 Hz
- Diagnosis and setup via optional keypad or PC software
- Optional Encoder evaluation

ROVING

A roving frame is used in the spinning process to produce a roving, which is a loosely twisted strand of fiber that can be feed into a spinning machine to produce yarn. The roving frame is part of the spinning process and is used to further align and draft the fibers into a more uniform strand as preparation for the ring spinning machine.

The process starts with the roving creel, which holds the bobbins of roving. The roving is then fed into the machine, where it is drafted and twisted to create a more uniform strand. The strand is then wound onto a bobbin by a rotating wing (flyer) which twists the material. The speed and tension of the roving frame can be adjusted to produce different weights and qualities of roving.

The roving produced by the roving frame is then used as a feedstock for ring spinning machines, which further stretch and twist the fibers to create finished yarns. Roving frames are used primarily in the production of wool, cotton, and synthetic fibers.

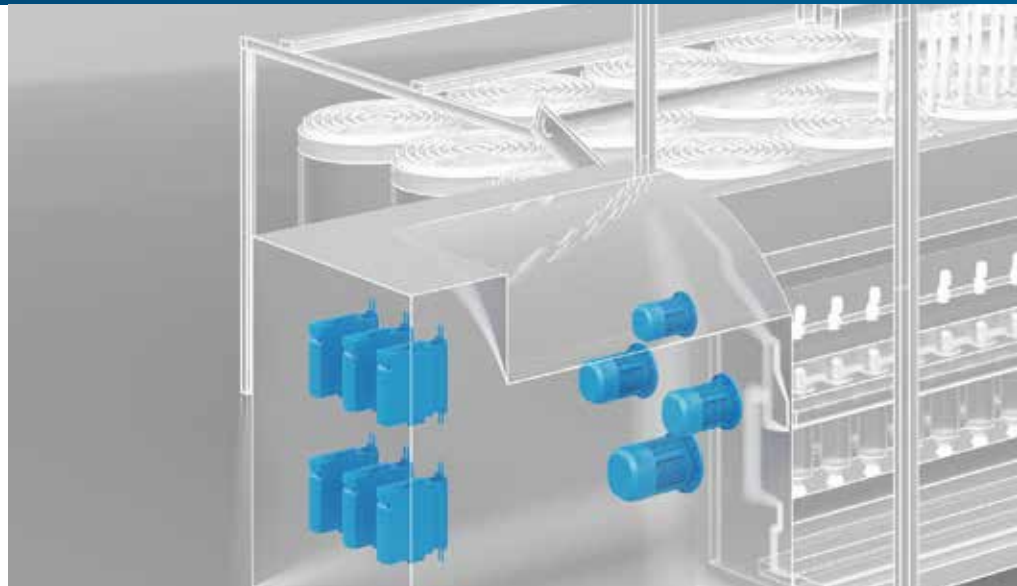

A series
Helical bevel
gearmotors

BENEFITS

- Compact
- Universal mounting
- Modular design
- Wash down capability

FEATURES

- Keyed hollow shaft (metric and inch series)
- High and premium efficiency motors (IE2, IE3)
- Wide range of feedback devices (incremental and absolute encoders)



F+BSR Series
Helical parallel-
shaft gearmotors
& units

- Easy installation
- Quiet operation
- High torque capabilities

- Keyed hollow shaft with two bore options per size, or hollow shaft with shrink disc fitting (metric and imperial dims)
- Backstop device
- Surface protection class C3, C4 and C5 (according to standard UNI EN ISO 12944-2)
- High and premium efficiency motors (IE2, IE3)
- Protection rating up to IP56
- Thermal protection (bi-metallic, PTC or KTY)
- Anti-condensation heaters and tropicalized windings



BX Series
Asynchronous IE3
Motors

- Reliability and robustness
- Different options like encoder and mechanical brake

- IE3 Efficiency class
- Power range: 0.75 to 22 kW
- Nominal speed range: 0 to 1500 rpm as 4 pole motor

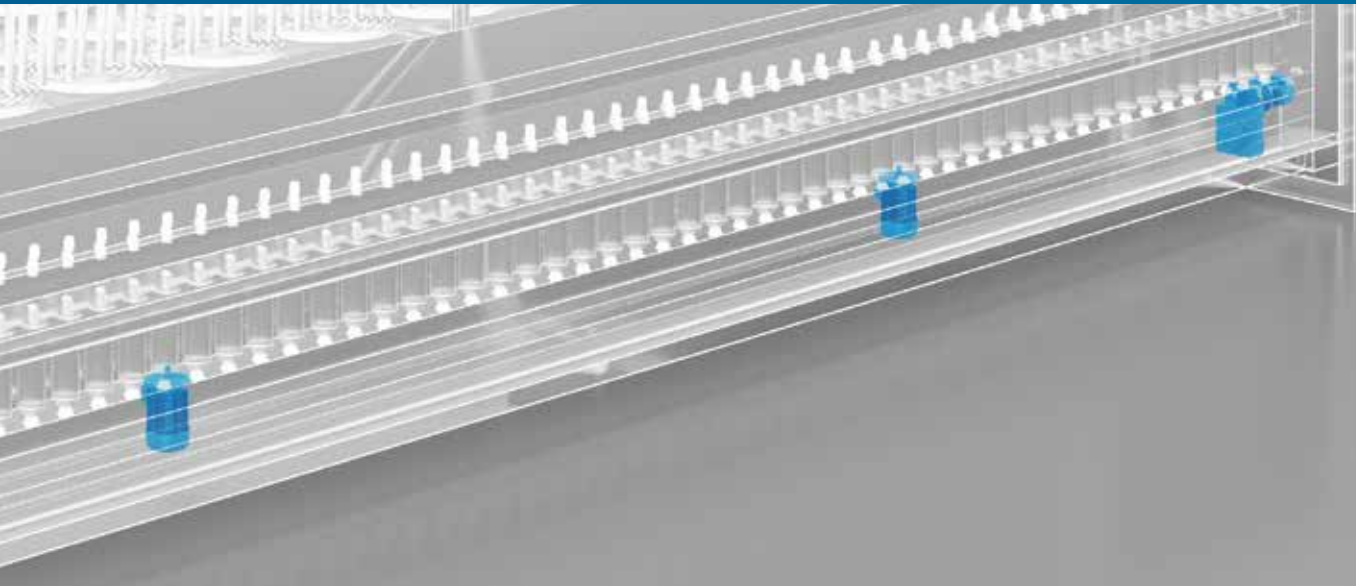

BSR Series

Synchronous Reluctance Motors

BENEFITS

- High dynamic capability
- Economic PM-servo replacement
- Reduced total cost of ownership (TCO)
- Adaptable to industrial gearboxes thanks to IEC design

FEATURES

- High energy efficiency of the drive system class up to IES2
- Motor efficiency class up to IE4
- Eco-friendly
- Two packages available: High Efficiency and High Output
- Power range: 0.37 to 18.5 kW
- Low rotor inertia
- Low heat dissipation
- High speed range: 0 to 4500 rpm (max)
- High torque at zero speed
- High Output motors have a reduced frame up to two sizes if compared with IM
- Optimized compatibility with Active Cube 410 frequency inverter series
- Effective torque and speed control (also at low speed) without encoder



Active Cube Series

Premium inverter

- Modular inverter platform to adapt the inverter to the machine
- Reliable and precise Process control
- Smooth Start and Stop control
- Power failure management with controlled ramp down

- Power range: 0.25 to 400 kW
- Speed or Torque Control
- Option modules to include field bus communication and encoder evaluation
- Plug-in power terminals (up to 4 kW)
- Plug-in and programmable control terminals
- DC link connection
- Integrated brake chopper
- Integrated VPLC
- Integrated safe torque off STO (SIL 3 / PL e) function
- Output frequency 0...599 Hz
- Diagnosis and setup via optional keypad or PC software
- Optional Encoder evaluation



AxiaVert Series

Premium inverter

Hi-dynamic electrical gearing

- High control performance for dynamic motion requirements
- Optimized performance for integrated Functional Safety
- Gateway for machine diagnostics, alarm management, predictive maintenance

- Wide range of advanced integrated functional safety capabilities
- Flexible communication protocols complying with automation and Industry 4.0 standards
- High Speed, Position and Torque control accuracy, with or without encoder feedback
- Wide range of optional modules
- IEC 61131-3 PLC programming
- Integrated device and application monitoring
- Control of a wide range of motor types supported, with top-of-the-range motion and control features
- Graphical user interface for PC and mobile devices, wired and wireless connectivity (USB, Bluetooth)
- Graphical keypad

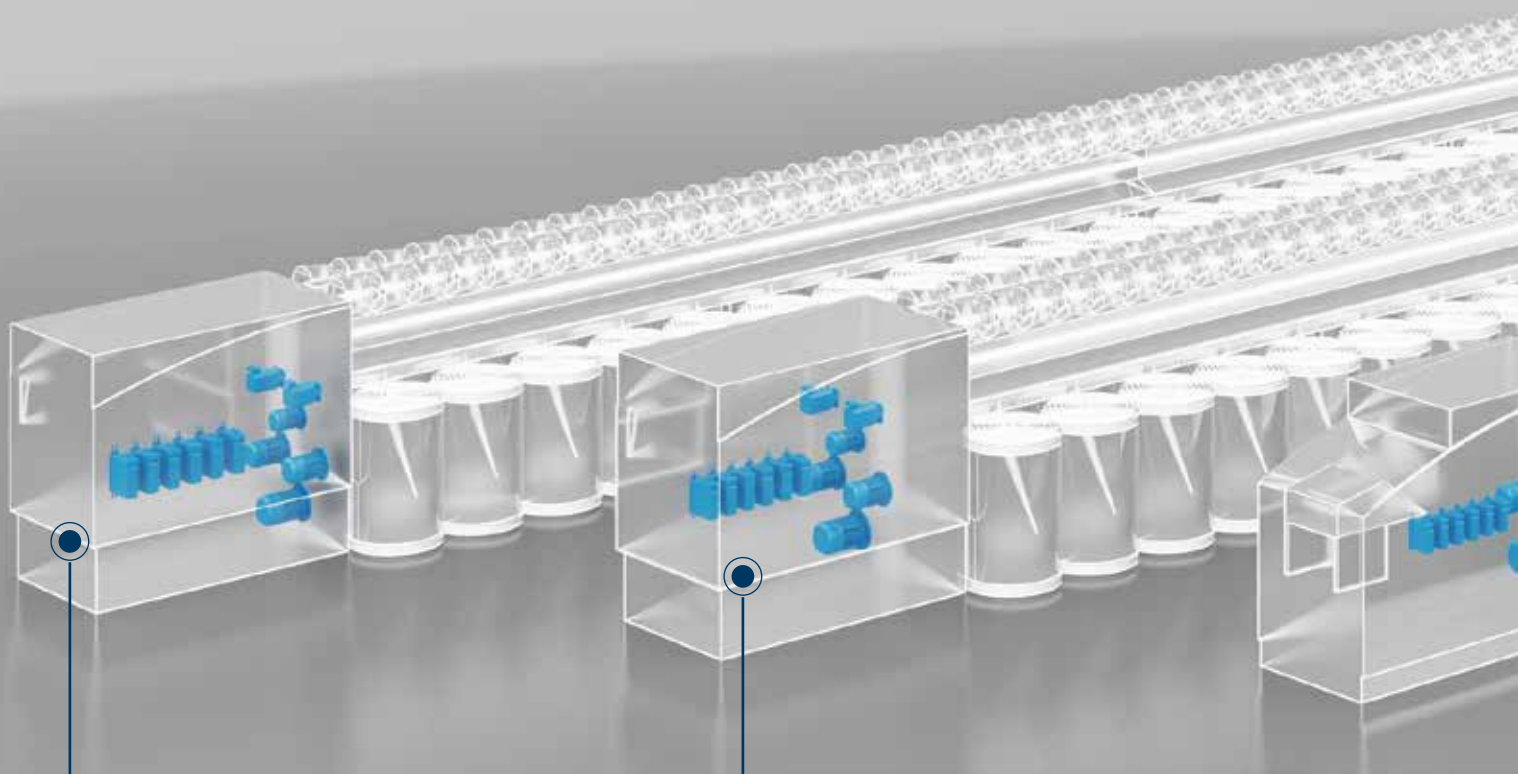

1 ROTOR SPINNING

2 AIR SPINNING

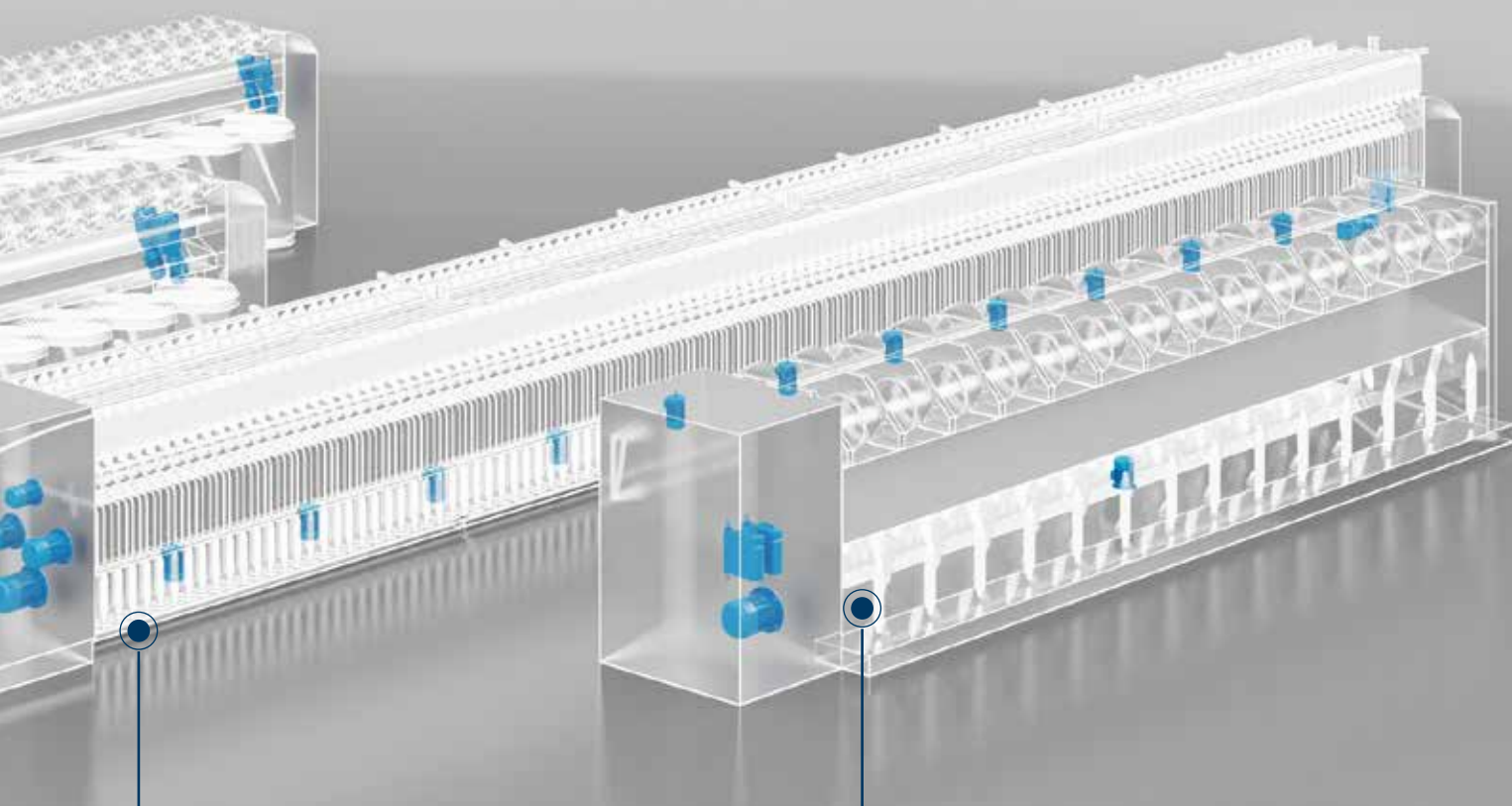

3 RING SPINNING

4 WINDING

1

ROTOR SPINNING

A rotor spinning machine is a type of spinning machine used in the textile industry to produce yarn from fibers such as cotton, wool, and synthetic fibers. The machine uses a rapidly rotating, perforated rotor to draw fibers into a chamber and twist them into yarn.

The process consists of a rotor with an opening through which fibers are fed into the rotor and are pressed into the rotor cup by centrifugal force. As the fibers are drawn out the rotor, they are twisted by the rotation of the rotor cup to form a continuous yarn. The yarn is then wound onto a package, which can be further processed into finished textiles.

The rotor spinning machine is known for its high production rate and efficiency, making it a popular method for producing large quantities of yarn. The machine can operate at high speeds enabling it to produce large quantities of yarn in a short amount of time. However, the yarn produced by rotor spinning typically has a lower quality than yarn produced by ring spinning, as it is hairier and has a rougher surface.

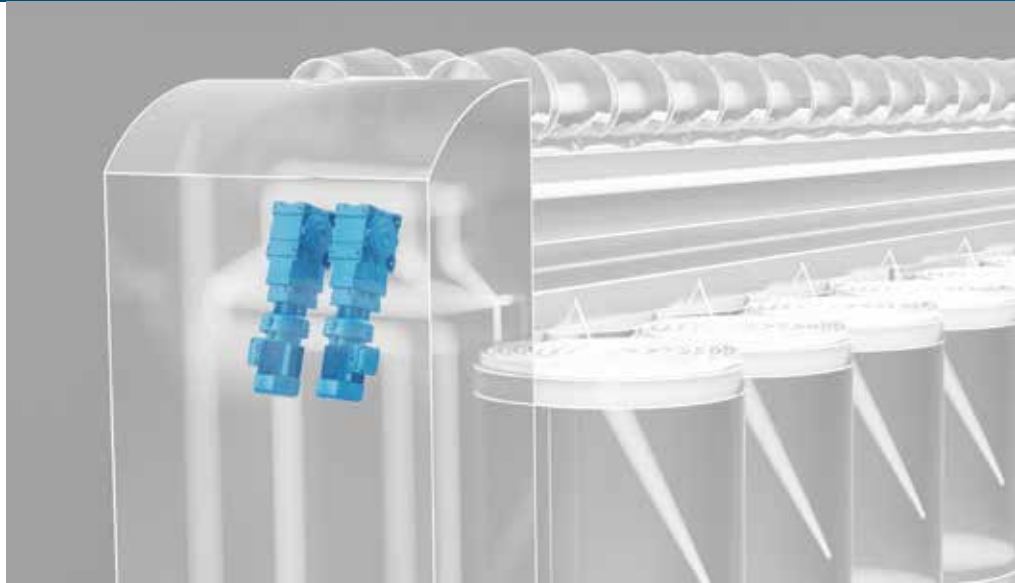

A+BMD Series

Helical bevel gearbox with Permanent magnet servo motor

BENEFITS

- High efficient solution
- Robust
- Compact

FEATURES

- Wide range of feedback devices
- Sensorless control available
- Modular design
- Optimized servo package



BMD Series For rounding units

BSR Series Synchronous Reluctance Motors

Active Cube Series Premium inverter

BENEFITS

- High torque density
- Compact design
- Wide range of feedback types
- Customized solutions

- High dynamic capability
- Economic PM-servo replacement
- Reduced total cost of ownership (TCO)
- Adaptable to industrial gearboxes thanks to IEC design

- Modular inverter platform to adapt the inverter to the machine
- Reliable and precise Process control
- Smooth Start and Stop control
- Power failure management with controlled ramp down

FEATURES

- High torque density and efficiency
- Wide range of feedback types

- High energy efficiency of the drive system class up to IES2
- Motor efficiency class up to IE4
- Eco-friendly
- Two packages available: High Efficiency and High Output
- Power range: 0.37 to 18.5 kW
- Low rotor inertia
- Low heat dissipation
- High speed range: 0 to 4500 rpm (max)
- High torque at zero speed
- High Output motors have a reduced frame up to two sizes if compared with IM
- Optimized compatibility with Active Cube 410 frequency inverter series
- Effective torque and speed control (also at low speed) without encoder

- Power range: 0.25 to 400 kW
- Speed or Torque Control
- Option modules to include field bus communication and encoder evaluation
- Plug-in power terminals (up to 4 kW)
- Plug-in and programmable control terminals
- DC link connection
- Integrated brake chopper
- Integrated VPLC
- Integrated safe torque off STO (SIL 3 / PL e) function
- Output frequency 0..599 Hz
- Diagnosis and setup via optional keypad or PC software
- Optional Encoder evaluation

AIR SPINNING

The air spinning machine is a type of spinning machine used in the textile industry to produce yarn from fibers such as cotton, wool, and synthetic fibers. The machine uses compressed air to twist and bind the fibers together into yarn by blowing them through a special design jet. At first the fibers will be opened and separated by a series of rollers. The separated fibers are then drawn through the compressed air jet, which creates a vortex that twists the fibers together and binds them into a continuous yarn. The yarn is then wound onto a package, which can be further processed into finished textiles.

Air spinning machines are known for their high production rate and efficiency, making them a popular choice for producing large quantities of yarn. They are also capable of producing yarn with unique characteristics, such as high bulkiness and low hairiness. However, the yarn produced by air spinning machines typically has a lower quality than yarn produced by ring spinning, with less strength and durability. Therefore, air spinning machines are often used to produce simple yarns for applications such as upholstery, non-woven fabrics, and the large, growing market of active wear.

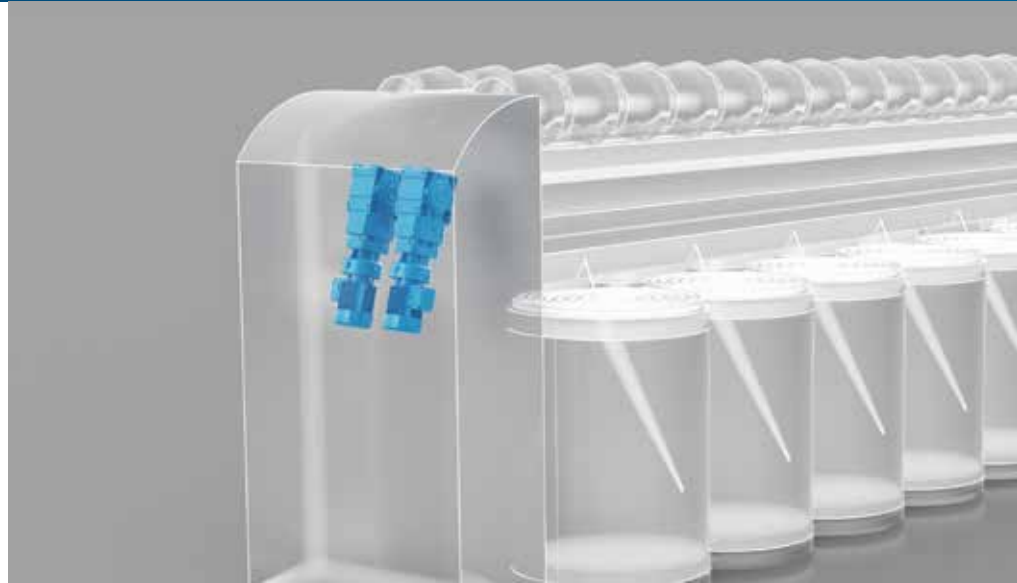

A+BMD Series

Helical bevel gearbox with Permanent magnet servo motor

BENEFITS

- High efficient solution
- Robust
- Compact

FEATURES

- Wide range of feedback devices
- Sensorless control available
- Modular design
- Optimized servo package

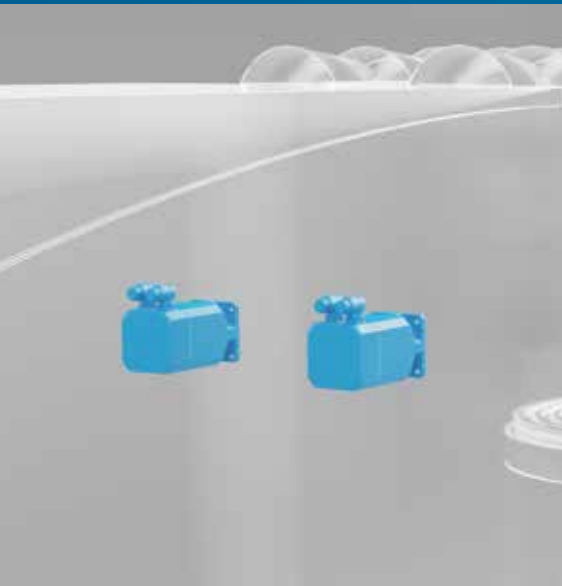

BMD Series
For rounding units



BSR Series
Synchronous Reluctance
Motors



Active Cube Series
Premium inverter

BENEFITS

- High torque density
- Compact design
- Wide range of feedback types
- Customized solutions

- High dynamic capability
- Economic PM-servo replacement
- Reduced total cost of ownership (TCO)
- Adaptable to industrial gearboxes thanks to IEC design

- Modular inverter platform to adapt the inverter to the machine
- Reliable and precise Process control
- Smooth Start and Stop control
- Power failure management with controlled ramp down

FEATURES

- High torque density and efficiency
- Wide range of feedback types

- High energy efficiency of the drive system class up to IES2
- Motor efficiency class up to IE4
- Eco-friendly
- Two packages available: High Efficiency and High Output
- Power range: 0.37 to 18.5 kW
- Low rotor inertia
- Low heat dissipation
- High speed range: 0 to 4500 rpm (max)
- High torque at zero speed
- High Output motors have a reduced frame up to two sizes if compared with IM
- Optimized compatibility with Active Cube 410 frequency inverter series
- Effective torque and speed control (also at low speed) without encoder

- Power range: 0.25 to 400 kW
- Speed or Torque Control
- Option modules to include field bus communication and encoder evaluation
- Plug-in power terminals (up to 4 kW)
- Plug-in and programmable control terminals
- DC link connection
- Integrated brake chopper
- Integrated VPLC
- Integrated safe torque off STO (SIL 3 / PL e) function
- Output frequency 0..599 Hz
- Diagnosis and setup via optional keypad or PC software
- Optional Encoder evaluation

RING SPINNING

The ring spinning machine produces yarn from fibers such as cotton, wool, and synthetic fibers. The machine is named after the ring that runs around the final bobbin and twists the yarn simply by using the mechanical friction of the ring.

The process starts with the roving, which is fed into the machine and guided through a series of rollers that further stretch and align the fibers. The roving is then fed onto a spinning bobbin, which is rotated at a high speed, twisting the fibers into a continuous yarn. The yarn is then wound onto a package, which can be further processed into finished textiles.

Ring spinning machines are known for producing high-quality yarn with a smooth surface, high strength, and low hairiness. They are widely used in the textile industry for producing a wide range of yarns of different counts and qualities. The machines are highly automated, with computer-controlled systems that allow for precise control of the spinning process, ensuring consistent yarn quality and productivity.

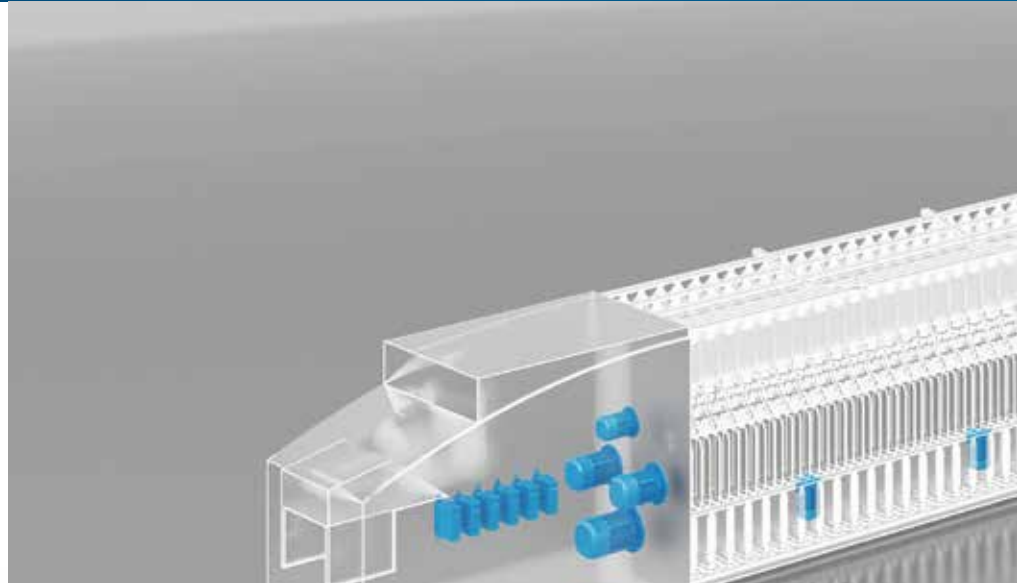

A series
Helical bevel
gearmotors



F Series
Helical parallel-
shaft gearmotors
& units



W/VF + BXN
Gearmotor for
pulling

BENEFITS

- Compact
- Universal mounting
- Modular design
- Wash down capability

- Easy installation
- Quiet operation
- High torque capabilities

- Price/Performance Effectiveness with AGL
- No sine filter required + Reduced Heat
- Emergency ramp to stop the spindle

FEATURES

- Keyed hollow shaft (metric and inch series)
- High and premium efficiency motors (IE2, IE3)
- Wide range of feedback devices (incremental and absolute encoders)

- Keyed hollow shaft with two bore options per size, or hollow shaft with shrink disc fitting (metric and imperial dims)
- Backstop device
- Surface protection class C3, C4 and C5 (according to standard UNI EN ISO 12944-2)
- High and premium efficiency motors (IE2, IE3)
- Protection rating up to IP56
- Thermal protection (bi-metallic, PTC or KTY)
- Anti-condensation heaters and tropicalized windings

- Speed feedback management with on-fly open loop
- High Switching Frequency
- Grid Power-off Control

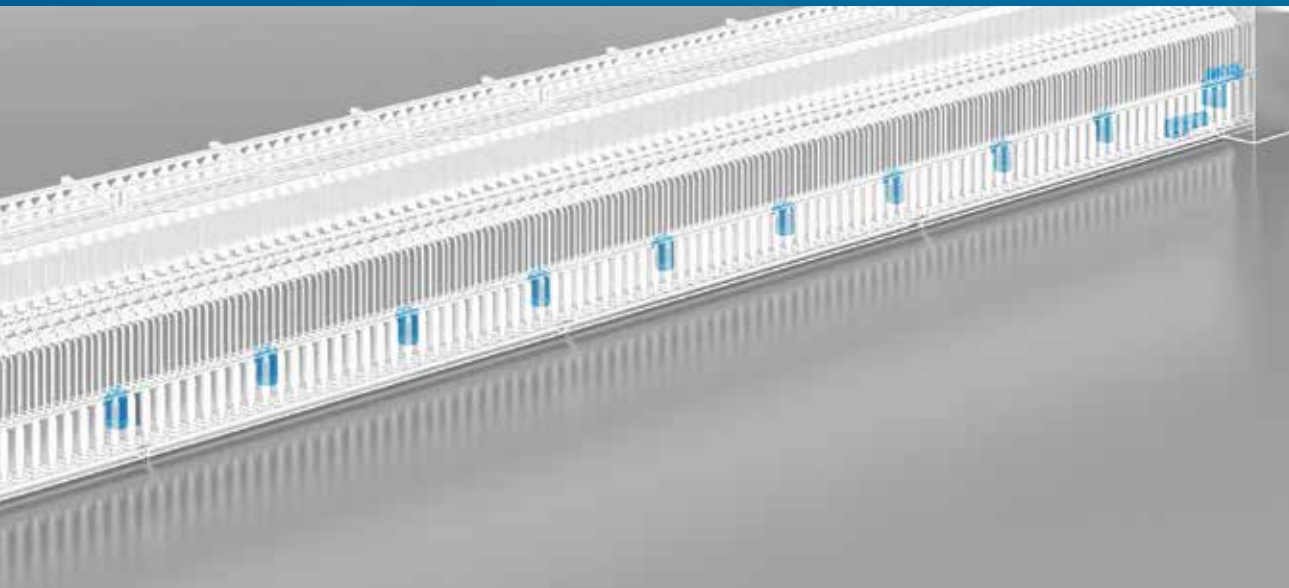

BX Series
Asynchronous IE3
Motors



MXN Series
Asynchronous
Motors



BSR Series
Synchronous
Reluctance Motors



Active Cube Series
Premium inverter

BENEFITS

- Reliability and robustness
- Different options like encoder and mechanical brake

- Compact design
- Wide choice of speeds
- Universal mounting position
- Feedback device (encoder) available as option

- High dynamic capability
- Economic PM-servo replacement
- Reduced total cost of ownership (TCO)
- Adaptable to industrial gearboxes thanks to IEC design

- Modular inverter platform to adapt the inverter to the machine
- Reliable and precise Process control
- Smooth Start and Stop control
- Power failure management with controlled ramp down

FEATURES

- IE3 Efficiency class
- Power range: 0.75 to 22 kW
- Nominal speed range: 0 to 1500 rpm as 4 pole motor

- IE3 solution
- Wide range of options and flanges

- High energy efficiency of the drive system class up to IES2
- Motor efficiency class up to IE4
- Eco-friendly
- Two packages available: High Efficiency and High Output
- Power range: 0.37 to 18.5 kW
- Low rotor inertia
- Low heat dissipation
- High speed range: 0 to 4500 rpm (max)
- High torque at zero speed
- High Output motors have a reduced frame up to two sizes if compared with IM
- Optimized compatibility with Active Cube 410 frequency inverter series
- Effective torque and speed control (also at low speed) without encoder

- Power range: 0.25 to 400 kW
- Speed or Torque Control
- Option modules to include field bus communication and encoder evaluation
- Plug-in power terminals (up to 4 kW)
- Plug-in and programmable control terminals
- DC link connection
- Integrated brake chopper
- Integrated VPLC
- Integrated safe torque off STO (SIL 3 / PL e) function
- Output frequency 0...599 Hz
- Diagnosis and setup via optional keypad or PC software
- Optional Encoder evaluation

WINDING

The winding machine is an advanced machine used in the textile industry for winding yarn onto packages. It is specifically designed to provide high-quality spools, improve productivity, and minimize yarn breakage during the winding process.

The machine is equipped with sensors and monitoring systems that detect yarn faults, such as yarn breaks, uneven tension, or yarn defects.

The process automatically stops the machine or takes corrective actions to minimize yarn waste and ensure consistent yarn quality.

Splicing or knotting techniques are used to join the yarn when there is a yarn break. These mechanisms ensure the smooth and efficient joining of yarn ends, minimizing interruptions in the winding process.

The machine is capable of producing various types of winding packages, including cylindrical cones or tubes, using different winding techniques. It can control the package shape, density, and traverse motion to optimize package formation.

Special tensioning devices control the yarn tension during winding.

Proper tension control is crucial for preventing yarn breaks, maintaining yarn quality, and achieving uniform package density.

It has automatic systems for package doffing (removal) and transport. It can handle large volumes of packages, enabling continuous operation and reducing downtime for package changeovers.

The process significantly improves winding efficiency, reduces yarn waste, and enhances overall productivity in the textile industry. Its automated features and advanced technology make it an essential component in modern textile manufacturing processes.



BSR Series Synchronous Reluctance Motors

BENEFITS

- High dynamic capability
- Economic PM-servo replacement
- Reduced total cost of ownership (TCO)
- Adaptable to industrial gearboxes thanks to IEC design

FEATURES

- High energy efficiency of the drive system class up to IES2
- Motor efficiency class up to IE4
- Eco-friendly
- Two packages available: High Efficiency and High Output
- Power range: 0.37 to 18.5 kW
- Low rotor inertia
- Low heat dissipation
- High speed range: 0 to 4500 rpm (max)
- High torque at zero speed
- High Output motors have a reduced frame up to two sizes if compared with IM
- Optimized compatibility with Active Cube 410 frequency inverter series
- Effective torque and speed control (also at low speed) without encoder



Active Cube Series

Premium inverter

BENEFITS

- Modular inverter platform to adapt the inverter to the machine
- Reliable and precise Process control
- Smooth Start and Stop control
- Power failure management with controlled ramp down

FEATURES

- Power range: 0.25 to 400 kW
- Speed or Torque Control
- Option modules to include field bus communication and encoder evaluation
- Plug-in power terminals (up to 4 kW)
- Plug-in and programmable control terminals
- DC link connection
- Integrated brake chopper
- Integrated VPLC
- Integrated safe torque off STO (SIL 3 / PL e) function
- Output frequency 0...599 Hz
- Diagnosis and setup via optional keypad or PC software
- Optional Encoder evaluation

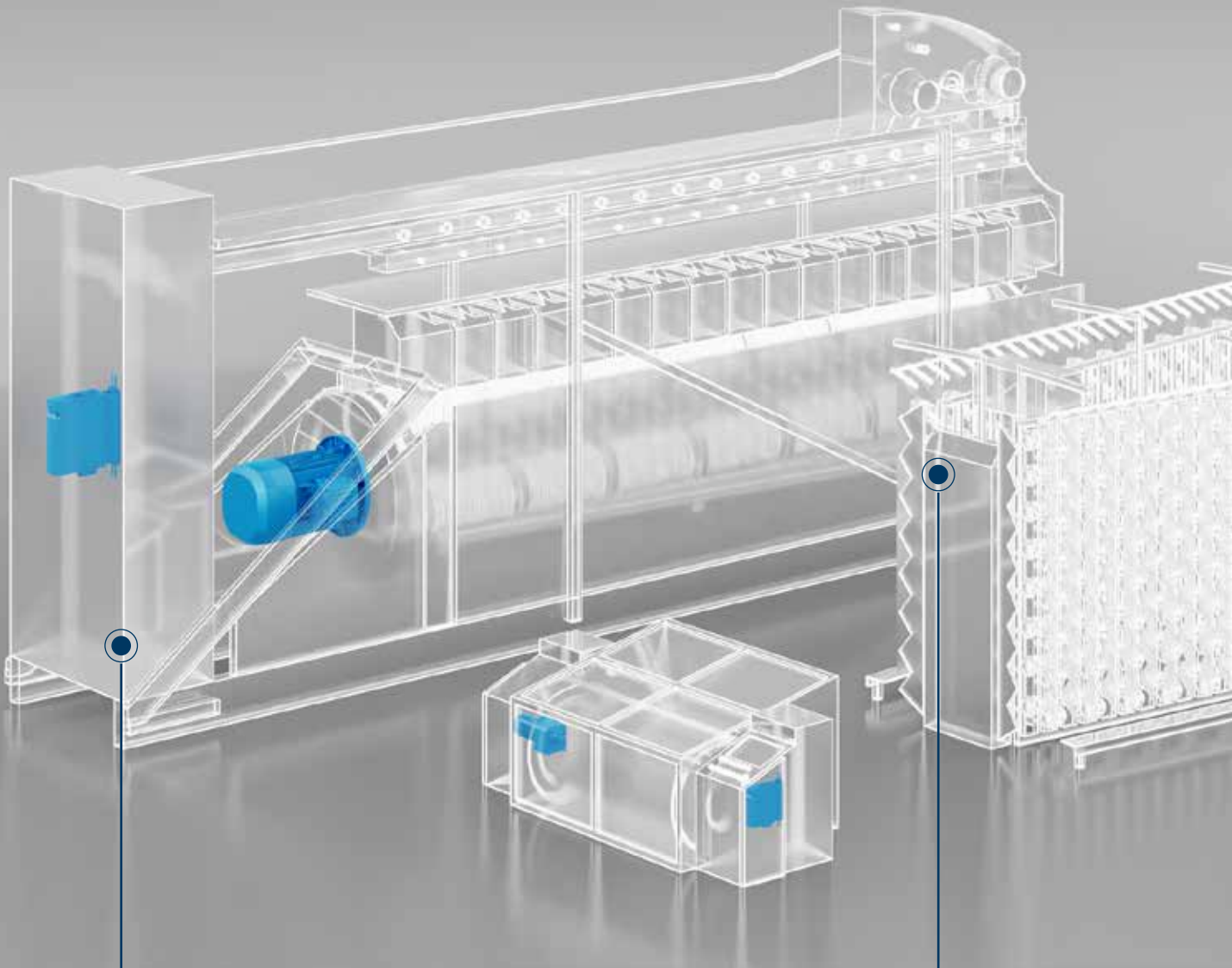

1 SYNTHETIC YARN EXTRUSION

2 BEAMING

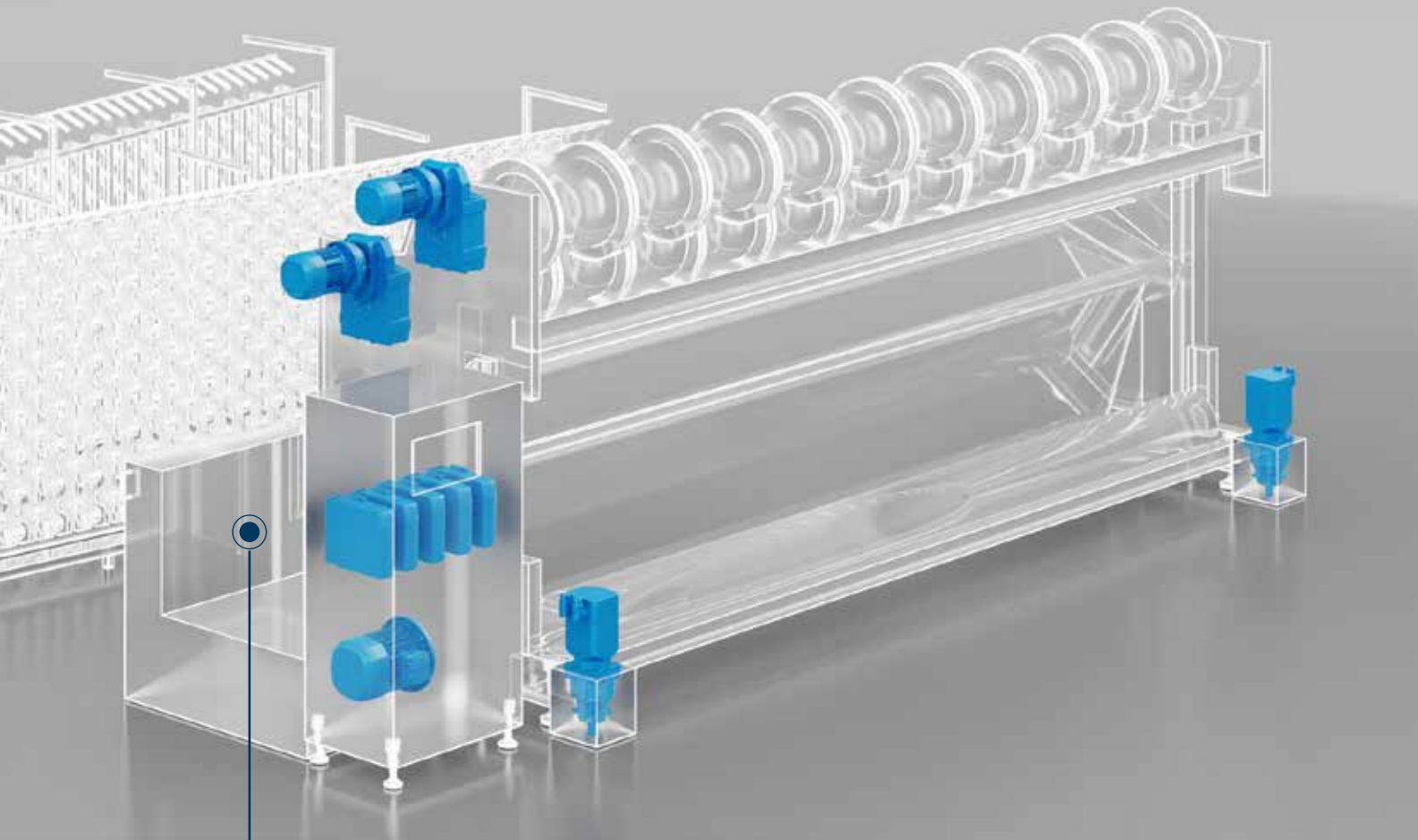

3 KNITTING

1

SYNTHETIC YARN EXTRUSION

Synthetic yarn extrusion is a process used in the textile industry to produce synthetic yarns from polymer resins such as polyester, nylon, and polypropylene. The process involves melting the polymer resin and forcing it through a spinneret, which is a metal plate with small holes or orifices.

The melted polymer is forced under high pressure through the small holes or orifices of the spinneret, forming long continuous filaments. The filaments are then cooled and solidified, either by being passed through a cooling chamber or sprayed with cool air or water.

After solidification, the filaments are drawn, which means they are stretched to align the polymer molecules and increase the strength of the yarn. The drawn filaments are then wound onto spools or bobbins for further processing or for use in textile products.

Synthetic yarn extrusion is a highly automated process that can produce yarns of different thicknesses, strengths, and textures, depending on the size and shape of the spinneret orifices, the polymer resin used, and the stretching process applied. The resulting yarns are durable, lightweight, and resistant to moisture, making them ideal for use in a wide range of applications, such as clothing, upholstery, and industrial fabrics.

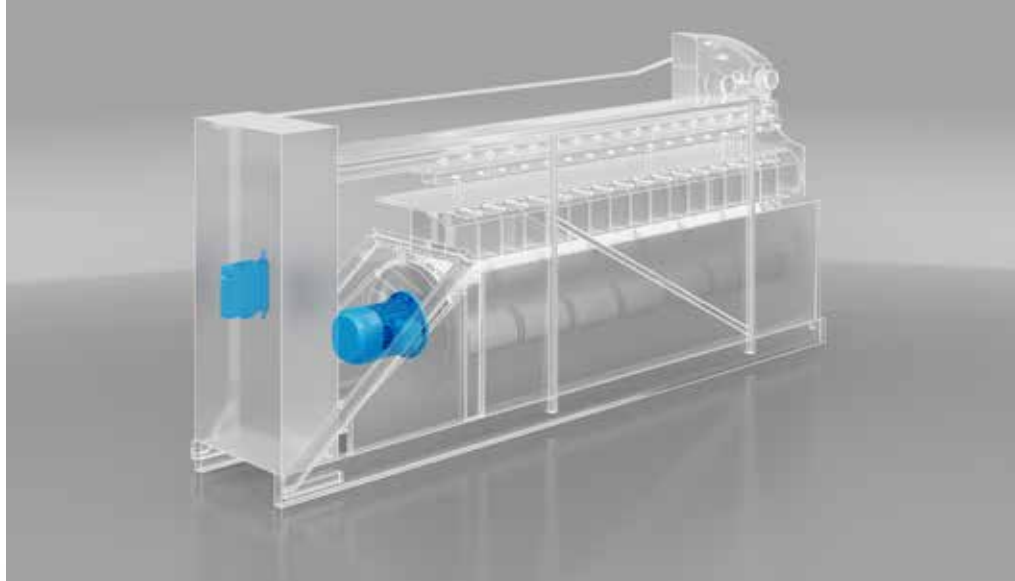

BSR Series Synchronous Reluctance Motors

BENEFITS

- High dynamic capability
- Economic PM-servo replacement
- Reduced total cost of ownership (TCO)
- Adaptable to industrial gearboxes thanks to IEC design

FEATURES

- High energy efficiency of the drive system class up to IES2
- Motor efficiency class up to IE4
- Eco-friendly
- Two packages available: High Efficiency and High Output
- Power range: 0.37 to 18.5 kW
- Low rotor inertia
- Low heat dissipation
- High speed range: 0 to 4500 rpm (max)
- High torque at zero speed
- High Output motors have a reduced frame up to two sizes if compared with IM
- Optimized compatibility with Active Cube 410 frequency inverter series
- Effective torque and speed control (also at low speed) without encoder



Active Cube Series Premium inverter

- Modular inverter platform to adapt the inverter to the machine
- Reliable and precise Process control
- Smooth Start and Stop control
- Power failure management with controlled ramp down

- Power range: 0.25 to 400 kW
- Speed or Torque Control
- Option modules to include field bus communication and encoder evaluation
- Plug-in power terminals (up to 4 kW)
- Plug-in and programmable control terminals
- DC link connection
- Integrated brake chopper
- Integrated VPLC
- Integrated safe torque off STO (SIL 3 / PL e) function
- Output frequency 0...599 Hz
- Diagnosis and setup via optional keypad or PC software
- Optional Encoder evaluation

2

BEAMING

The knitting machine is used in the textile industry for creating knitted fabrics. It uses a series of hooks or needles to create loops in the yarn, which are then joined together to create a fabric.

Knitting machines come in different sizes and configurations, depending on the type of fabric being produced. Some machines are designed to create flat fabrics, while others can produce tubular fabrics, such as those used in the production of socks and gloves.

The process of operating a knitting machine involves loading the yarn onto the machine, threading it through the needles or hooks, and then using a crank or motor to move the needles or hooks back and forth, which creates the loops in the yarn. The fabric is created by joining the loops together in a continuous process.

Knitting machines can be used for creating a wide range of fabrics, from lightweight and stretchy materials to heavy and durable fabrics suitable to be used for outerwear. They are commonly used in the production of clothing, accessories, and home furnishings.

They also allow for the creation of complex designs and patterns with ease, making them a valuable tool for the textile industry.

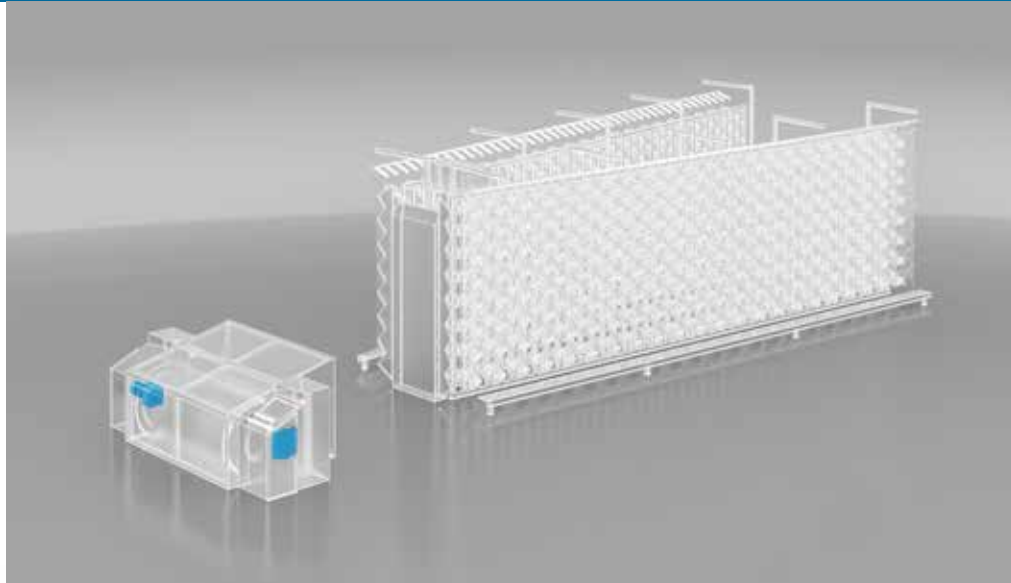

EVOX CP Series Helical in-line gearbox and geared motor

BENEFITS

- Compact gearmotor design
- High shock load resistance
- One-stop-shop for complete drive solutions
- Wash down capability

FEATURES

- Surface protection
- Universal motor voltage (BXN/MXN)
- High and premium efficiency motors (IE2, IE3)
- Protection rating up to IP56
- Total quality inspection certificate



Active Cube Series Premium inverter

- Modular inverter platform to adapt the inverter to the machine
- Reliable and precise Process control
- Smooth Start and Stop control
- Power failure management with controlled ramp down

- Power range: 0.25 to 400 kW
- Speed or Torque Control
- Option modules to include field bus communication and encoder evaluation
- Plug-in power terminals (up to 4 kW)
- Plug-in and programmable control terminals
- DC link connection
- Integrated brake chopper
- Integrated VPLC
- Integrated safe torque off STO (SIL 3 / PL e) function
- Output frequency 0...599 Hz
- Diagnosis and setup via optional keypad or PC software
- Optional Encoder evaluation

KNITTING

Bonfiglioli offers different drive concepts for warp knitting machines: IP65 asynchronous motors, IP65 and IP67 synchronous motors and synchronous reluctance motors up to IE4 Super Premium efficiency class for the optimum performance and power requirements of your machine. Bonfiglioli inverter series offer excellent speed and position control for the main axis and beam axis. The dedicated design allows operation in the demanding environments typical of warp knitting machines. The frequency inverter series are available with dedicated cooling concepts and coated printed circuit boards, which allow them to cope with high temperature environments.

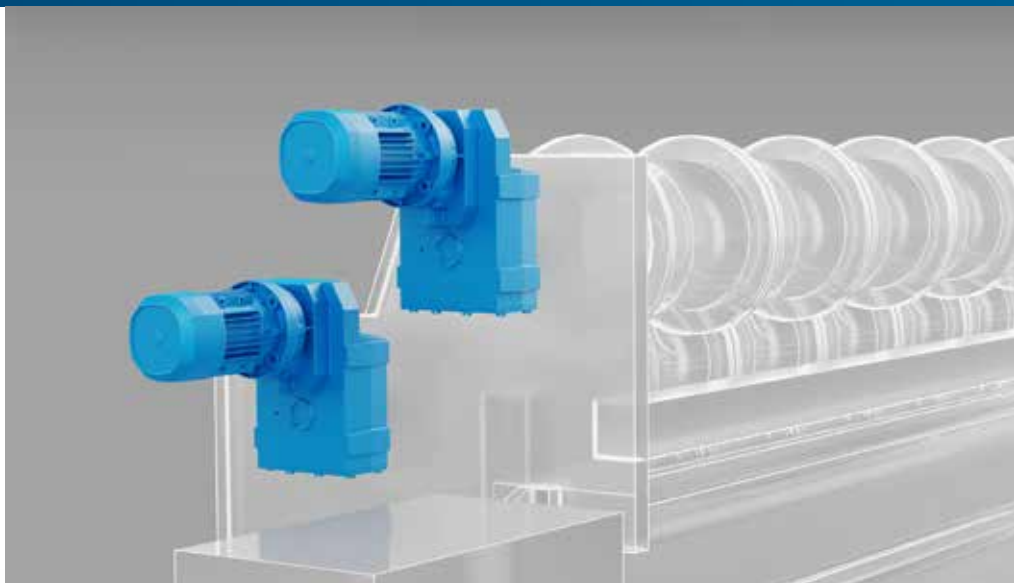

F Series
Helical parallel-shaft
gearmotors & units



BX Series
Asynchronous IE3 Motors

BENEFITS

- Easy installation
- Quiet operation
- High torque capabilities

- Reliability and robustness
- Different options like encoder and mechanical brake

FEATURES

- Keyed hollow shaft with two bore options per size, or hollow shaft with shrink disc fitting (metric and imperial dims)
- Backstop device
- Surface protection class C3, C4 and C5 (according to standard UNI EN ISO 12944-2)
- High and premium efficiency motors (IE2, IE3)
- Protection rating up to IP56
- Thermal protection (bi-metallic, PTC or KTY)
- Anti-condensation heaters and tropicalized windings

- IE3 Efficiency class
- Power range: 0.75 to 22 kW
- Nominal speed range: 0 to 1500 rpm as 4 pole motor

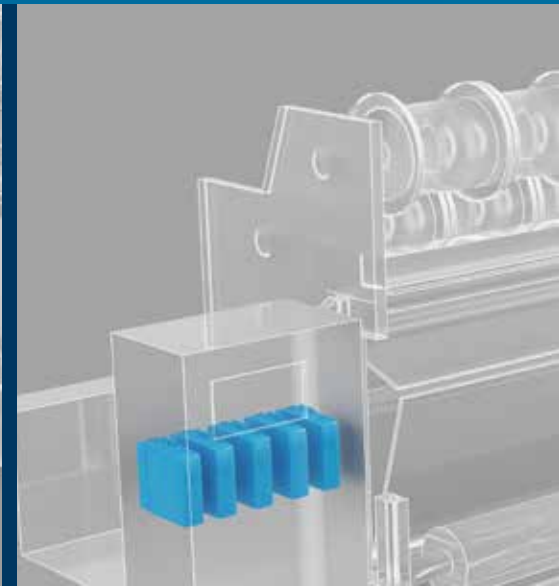
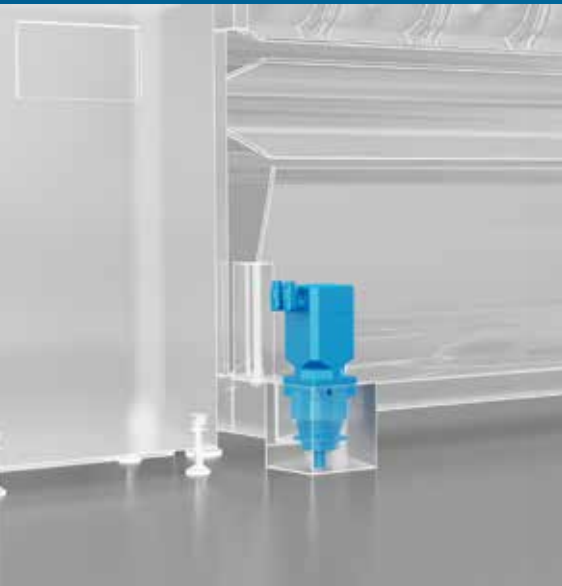

TQ+BMD Series

Precision Planetary Gearbox
+ Permanent Magnet Servo Motor

- High precision and dynamic
- Highly compact
- High stiffness
- Designed for continuous and intermittent duty



BSR Series

Synchronous Reluctance Motors

- High dynamic capability
- Economic PM-servo replacement
- Reduced total cost of ownership (TCO)
- Adaptable to industrial gearboxes thanks to IEC design



AxiaVert Series

Premium inverter
Hi-dynamic electrical gearing

- High control performance for dynamic motion requirements
- Optimized performance for integrated Functional Safety
- Gateway for machine diagnostics, alarm management, predictive maintenance

BENEFITS

FEATURES

- Different feedback systems available
- Brake option
- Inertia flywheel
- Customized windings on request
- Windings, pinning and labeling on request

- High energy efficiency of the drive system class up to IES2
- Motor efficiency class up to IE4
- Eco-friendly
- Two packages available: High Efficiency and High Output
- Power range: 0.37 to 18.5 kW
- Low rotor inertia
- Low heat dissipation
- High speed range: 0 to 4500 rpm (max)
- High torque at zero speed
- High Output motors have a reduced frame up to two sizes if compared with IM
- Optimized compatibility with Active Cube 410 frequency inverter series
- Effective torque and speed control (also at low speed) without encoder

- Wide range of advanced integrated functional safety capabilities
- Flexible communication protocols complying with automation and Industry 4.0 standards
- High Speed, Position and Torque control accuracy, with or without encoder feedback
- Wide range of optional modules
- IEC 61131-3 PLC programming
- Integrated device and application monitoring
- Control of a wide range of motor types supported, with top-of-the-range motion and control features
- Graphical user interface for PC and mobile devices, wired and wireless connectivity (USB, Bluetooth)
- Graphical keypad

Specific functions for the textile sector

SOFTWARE ENGINEERING MADE EASY

For different application purposes the Bonfiglioli frequency inverters offer fitting software functions:

- Speed Control and its extensions for machines with and without encoder feedback
 - Speed control
 - Torque control with jerkless switch over between speed control and torque control
 - Process control with a PI or PID controller
 - Winding control
 - Master/Slave operation via Systembus
 - Positioning control according to CiA 402 standard
- Signaling of abnormal behavior with warning and fault messages (via LED, digital outputs or Fieldbus)
- Machine depending setup of fault behavior and threshold levels for warnings and faults
- Error history and actual values history (average values & maximum values)

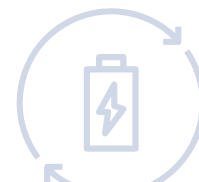

ENERGY EFFICIENCY

For a responsible resource usage, energy efficiency is a major task today for every production machine to reduce the ecological impact and saving operation costs at the same time.

The following approaches help to increase the energy efficiency of the drives and therefore for the whole machine:

- Smart energy usage
- Converting energy with high efficiency
- Using kinetic energy during braking
- Reducing energy consumption through energy saving functions in the frequency inverter

The full Bonfiglioli axis (inverter + gearbox + motor) offers a complete package of highly dynamic drive systems for increasing production efficiency.

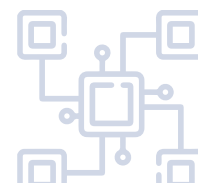

CONNECTIVITY: OPEN STANDARDS

Fieldbus connectivity for CANopen, EtherCAT, PROFINET, VARAN, PROFIBUS links the frequency inverter to the preferred PLC system.

The Ethernet based systems EtherCAT & PROFINET allow also simultaneous access for the diagnosis (and also parameter setup) via VPlus on the PC.

Field bus	
CANopen	EtherCAT
Profibus DP V1	Profinet
RS-232	Ethernet/IP
RS-485 (Modbus or VABus)	Modbus/TCP
DeviceNet	VABus/TCP



TRAVERSING FUNCTION

Traversing functions are important to ensure high material quality of the final product.

A typical setup involves a master/slave relation through a Systembus connection, where the traversing is adjusted automatically in both master and slave inverters to ensure the required yarn layout on the bobbin.

HARSH ENVIRONMENTS

- DC-Bus & Mains failure: we take care that the machine can react during a power failure with a managed ramp down and in this way material damages (i.e. yarn breaks) can be prevented.
- Products for use in high temperature environments: thanks to the cold plate and the feedthrough solutions, the heat losses are outside the cabinet, allowing space savings. Device variants without fans and without electrolyte capacitors improve the longevity of the inverters and their robustness to work in harsh environments (high temperature).
- Alternative cooling concepts for frequency and servo inverter
- Availability of coated printed circuit boards

R&D Capacity

DESIGN SIMULATION



TESTING
LABORATORIES



CO-ENGINEERING



The R&D department at Bonfiglioli develops cutting-edge solutions that integrate the most advanced mechanical, electrical, electronic and hydraulic technologies, responding to the most complex application challenges. **Each R&D center focuses on dedicated product lines, ensuring specialist know-how and tailor-made innovation.**

R&D CENTERS WORLDWIDE



ITALY

Bologna
Rovereto
Forlì



GERMANY

Hattingen
Krefeld



INDIA

Chennai



CHINA

Shanghai



Production: the heart of our company

OUR PRODUCTION SITES COMBINE INNOVATION AND PRECISION, REDEFINING THE CONCEPT OF OPERATIONAL EXCELLENCE.



With a fleet of 200 collaborative, high-capacity robots joining our AGVs/AMRs, we have built a seamlessly integrated **automated production ecosystem**.

We bridge the gap between production and IT infrastructure thanks to end-to-end digital integration, ensuring real-time monitoring and data-driven optimization.



From smart picking in our **advanced warehouses** to dynamic shipping, we guarantee agile, reliable and fast global delivery.

Our worldwide presence

Thanks to an international network of closely interconnected commercial and production sites, we can guarantee the same high standards of Bonfiglioli quality anywhere at any given time. We know that our direct presence in local markets is the key to long-lasting success, so our family includes 17 production sites, 23 commercial sites and more than 550 distributors around the world.

Our organization is always close by, offering complete and efficient solutions and supporting our customers with dedicated services, co-engineering and after-sales assistance.

17  PRODUCTION SITES

23  COMMERCIAL SITES

80  COUNTRIES

550  DISTRIBUTORS

~5,000  PEOPLE



Bonfiglioli global locations

AUSTRALIA

Bonfiglioli Transmission (Aust.) Pty Ltd
Plumpton NSW



BRAZIL

Bonfiglioli Redutores do Brasil Ltda
São Bernardo do Campo - São Paulo



CHINA

Bonfiglioli Drives (Shanghai) Co. Ltd.
Shanghai



Selcom Electronics (Shanghai) Co., Ltd
Shanghai



Shanghai



FRANCE

Bonfiglioli Transmission S.A.S.
Marly la Ville



GERMANY

Bonfiglioli Deutschland GmbH
Neuss



Bonfiglioli Deutschland GmbH
Krefeld



O&K Antriebstechnik GmbH
Hattingen



INDIA

Bonfiglioli Transmission Ltd.
Mobility & Wind Industries

Thirumudivakkam
Kancheepuram - Tamil Nadu



Industry & Automation Solutions
Mannur Village, Sriperumbudur Taluk
Kancheepuram - Tamil Nadu



Industry & Automation Solutions
Pune - Maharashtra



ITALY

Bonfiglioli Riduttori S.p.A.
Industry & Automation Solutions
Calderara di Reno (BO)



Industry & Automation Solutions
Carpiano



Mobility & Wind Industries
Forlì



Industry & Automation Solutions
Rovereto



Selcom Group S.p.A.
Castel Maggiore (BO)



Castel Maggiore (BO)



Cadriano (BO)



NEW ZEALAND

Bonfiglioli Transmission (Aust.) Pty Ltd
Auckland - Ellerslie



SINGAPORE

Bonfiglioli South East Asia Pte Ltd
Singapore



SLOVAKIA

Bonfiglioli Slovakia s.r.o.
Považská Bystrica



SOUTH AFRICA

Bonfiglioli South Africa Pty Ltd.
Johannesburg



SPAIN

Tecnotrans Bonfiglioli S.A
Castellbisbal - Barcelona



TURKEY

Bonfiglioli Türkiye Jsc
Çiğli - Izmir



UNITED KINGDOM

Bonfiglioli UK Ltd.
Warrington - Cheshire
Tel. +44 1925 852667



USA

Bonfiglioli USA Inc.
Hebron - Kentucky



VIETNAM

Bonfiglioli Vietnam Co. Ltd.
Ben Cat city, Binh Duong province





We have a relentless commitment to excellence, innovation & sustainability. Our team creates, distributes and services world-class power transmission & drive solutions to keep the world in motion.

HEADQUARTERS

Bonfiglioli S.p.A.

Via Cav. Clementino Bonfiglioli, 1
40012 Calderara di Reno - Bologna (Italy)
Tel. +39 051 6473111

