

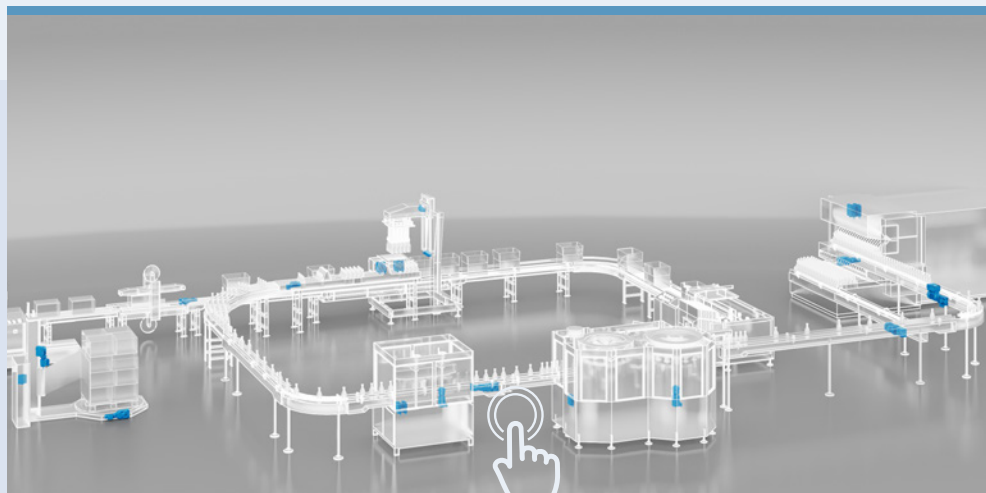

Solutions for **PACKAGING**

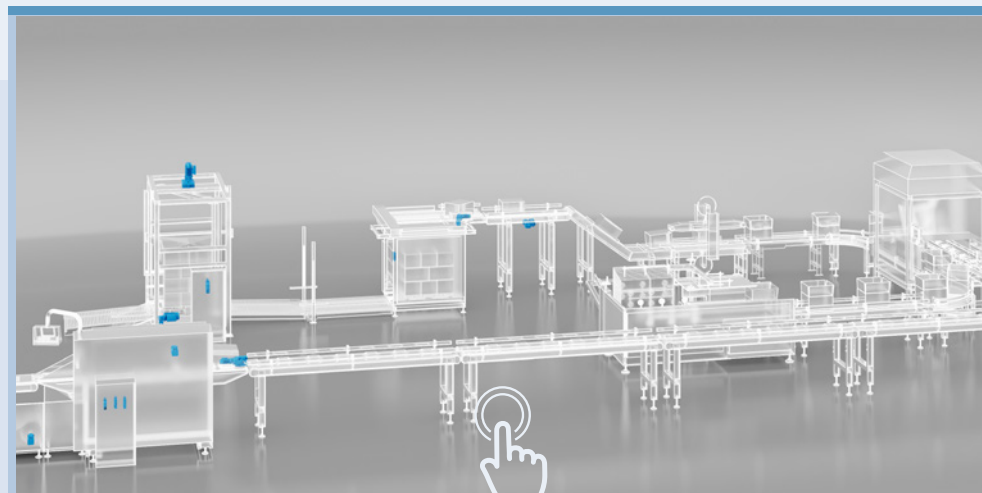

**LIQUID FILLING
PROCESS**



**SOLID PACKAGING
PROCESS**





4

TERTIARY PACKAGING
PALLETIZING & WRAPPING MACHINES



3

SECONDARY PACKAGING
CARTON FORMING MACHINES, PICK &
PLACE, CARTON CLOSING MACHINE



2

PRIMARY PACKAGING
FILLING, DOSING, CAPPING
& LABELING MACHINE



1

**CLEANING, STERILIZING
& DRYING**
BOTTLE WASHER MACHINE

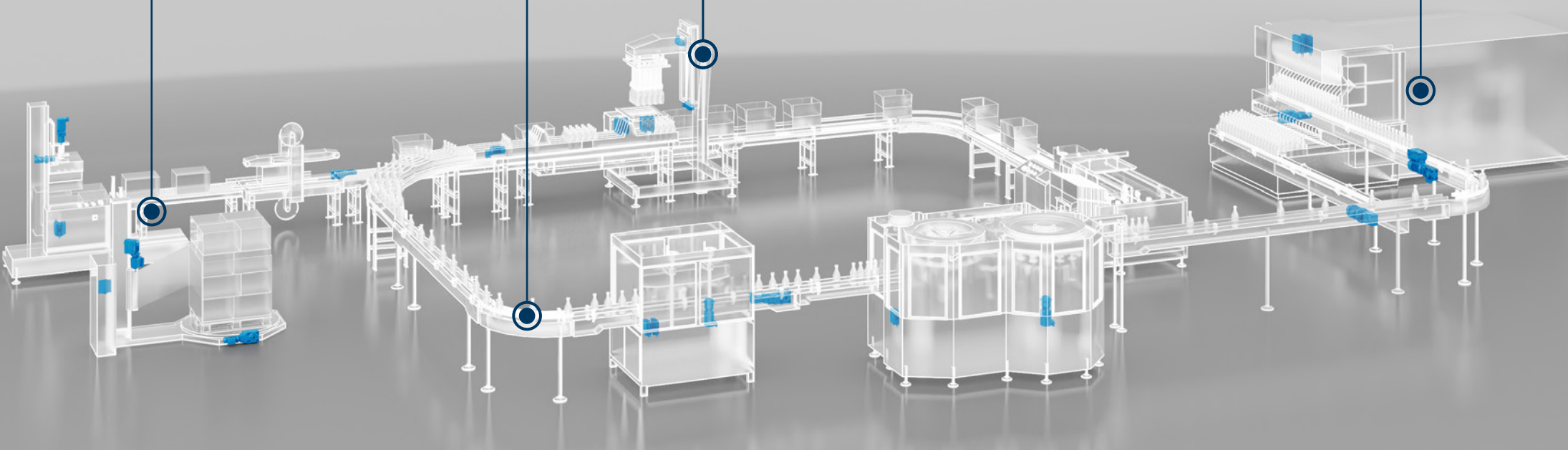

1

CLEANING, STERILIZING & DRYING

BOTTLE WASHER MACHINE

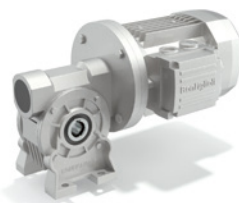
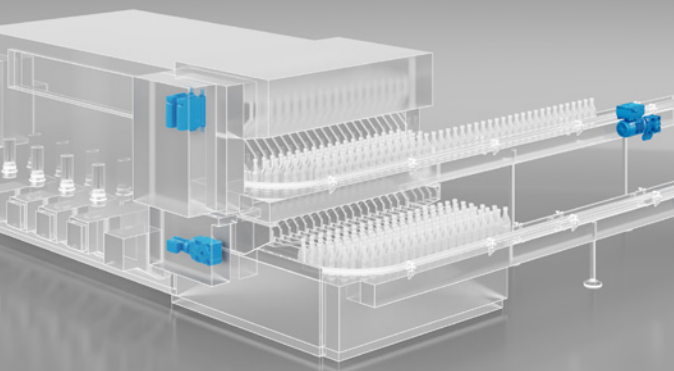

VF/W Series

Universal Worm
Gearmotors & Units

BENEFITS

- Reliability and robustness
- Uncompromising quality
- EP version specially designed for food & beverage industries
- Cost effective

FEATURES

- High and premium efficiency motors (IE2, IE3)
- Flexible to adapt to several different installing/mounting options

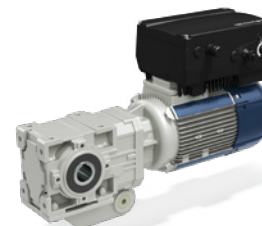

A+DGM Series

Helical Bevel
Gearmotors & Units

- Compact
- Universal mounting
- Modular design

- Keyed hollow shaft (metric and inch series)
- High and premium efficiency motors (IE2, IE3)
- Wide range of field buses (Ethernet base or/and CANopen)
- STO operating safety option



Active Cube Series

Premium Inverter

- Interpolated operating mode
- Smooth start
- Torque control
- Position and speed closed loop control

- Series optionally extendable for field bus communication and encoder evaluation
- Plug-in power terminals (up to 3kW)
- Plug-in and programmable control terminals
- DC link connection
- Integrated brake chopper
- Positioning function via field bus (motion control compatible to CiA DS402)
- Integrated VPLC
- Master/slave function with electronic gear
- Power failure control
- Integrated safe torque off STO (SIL 3 / PL e) function

< BACK



2

PRIMARY PACKAGING

FILLING, DOSING, CAPPING
& LABELING MACHINE

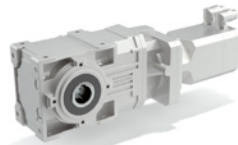
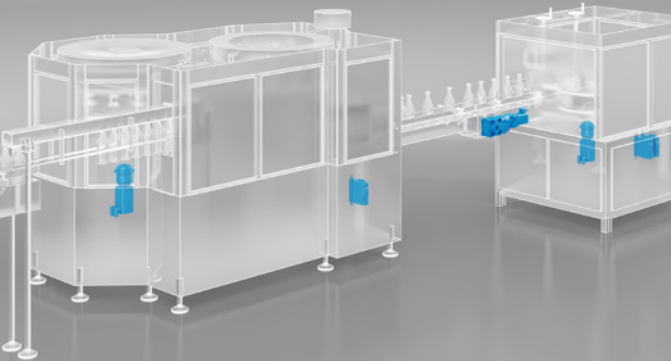

A+BMD Series

Helical Bevel Gearmotors
& Units + Permanent
Magnet Servo Motor

BENEFITS

- Highly dynamic
- Energy-saving solution
- Reduced installation space
- Reinforced bearings
- Wide range of accessories such as:
 - Torque arm
 - Fluoroelastomer oil seals
 - Taconite seals

FEATURES

- Reduced backlash option RB
- IP 65 (standard) and up to IP 67 protection
- Wide output speed selection range
- Wide range of options & customization such as:
 - feedback devices (incremental and absolute encoders)
 - Connectors
 - Brake size and type
 - Painting & protection for special environments

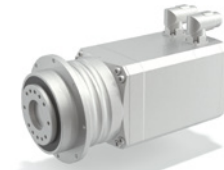

BMS Series

Flanged Servo Gearmotor

- Compact design
- High precision and dynamic (torsional stiffness)
- Universal mounting position

- High torque density
- Wide torque range
- 1600/3000/4500/6000 rpm nominal speed
- Low voltage versions on demand
- High degree of protection
- Wide range of options & customization such as:
 - feedback devices (incremental and absolute encoders)
 - Connectors
 - Brake size and type
 - Painting & protection for special environments



ANG Series

Servo Inverter

- Interpolated mode
- Fast loop control
- 2 encoder inputs

- Different variants include field bus connection and encoder evaluation
- Plug-in power terminals (up to 3kW)
- Plug-in and programmable control terminals
- DC link connection
- Integrated brake chopper
- Positioning function via field bus (motion control compatible to CiA DS402)
- Cubic interpolation
- Integrated VPLC
- Master/slave function with electronic gear
- Power failure control
- Integrated safe torque off STO (SIL 3 / PL e) function
- Output frequency 0...599 Hz, higher frequencies on request
- Diagnosis and setup via optional keypad or PC software





3

SECONDARY PACKAGING
CARTON FORMING MACHINES, PICK &
PLACE, CARTON CLOSING MACHINE

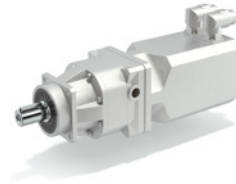
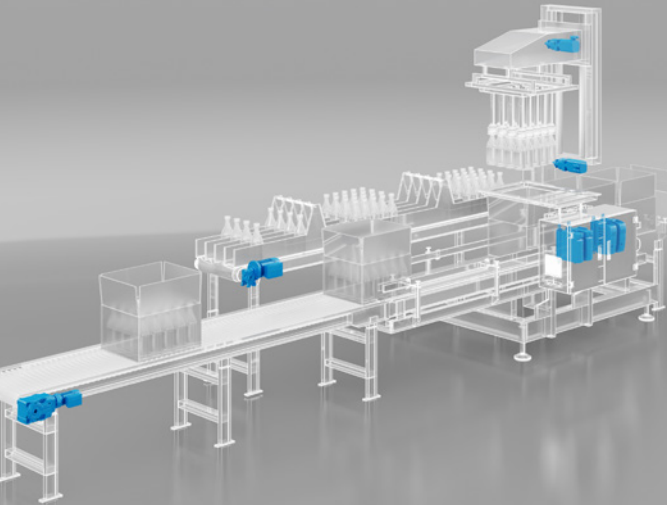

TQ+BMD Series

Precision Planetary
Gearbox + Permanent
Magnet Servo Motor

BENEFITS

- High precision and dynamic
- Highly compact
- High stiffness
- Designed for continuous and intermittent duty

FEATURES

- Different feedback systems available
- Brake option
- Inertia flywheel
- Customized windings on request
- Windings, pinning and labeling on request



ACTIVE CUBE SERIES
PREMIUM INVERTER



A+MXN Series

Right angle Helical
Bevel Gearmotor +
Asynchronous Motor

- Compact
- Universal mounting
- Modular design

- Keyed hollow shaft (metric and inch series)
- Premium efficiency motors IE3
- Reduced backlash



VF+MXN Series

Worm Gearmotors +
Asynchronous Motor

- Cost effective
- Uncompromising quality
- EP version specially designed for food & beverage industries
- Compact design

- Premium efficiency motors IE3



AGILE SERIES
SMART INVERTER



< **BACK**

3

SECONDARY PACKAGING
CARTON FORMING MACHINES, PICK &
PLACE, CARTON CLOSING MACHINE

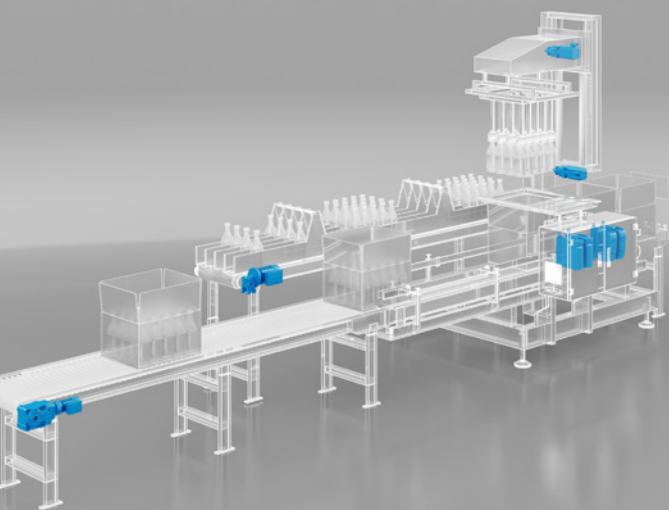

Active Cube Series
Premium Inverter

BENEFITS

- Interpolated operating mode
- Smooth start
- Torque control

FEATURES

- Series optionally extendable for field bus communication and encoder evaluation
- Plug-in power terminals (up to 3kW)
- Plug-in and programmable control terminals
- DC link connection
- Integrated brake chopper
- Positioning function via field bus (motion control compatible to CiA DS402)
- Integrated VPLC
- Master/slave function with electronic gear
- Power failure control
- Integrated safe torque off STO (SIL 3 / PL e) function
- Output frequency 0...599 Hz, higher frequencies on request
- Diagnosis and setup via optional keypad or PC software



Agile Series
Smart Inverter

- Low energy consumption
- Flexibility
- Preset values for Bonfiglioli motors to decrease commissioning times
- Very high power density
- Compactness
- Smart mounting to save space into the cabinet

- Series optionally extendable for field bus communication
- Sensorless synchronous and asynchronous motor control
- Modbus and Systembus onboard
- DC link connection
- Integrated brake chopper
- Power failure control
- Programmable PI controller
- Integrated VPLC
- Master/slave function with electronic gear
- Integrated safe torque off STO (SIL 2 / PL d) function
- Energy saving function
- Smart current limits
- Output frequency 0...599 Hz, higher frequencies on request
- Diagnosis and setup via integrated keypad and integrated service interface for PC connection

< BACK



A+MXN Series
Right angle Helical
Bevel Gearmotor +
Asynchronous Motor

BENEFITS

- Compact
- Universal mounting
- Modular design

FEATURES

- Keyed hollow shaft (metric and inch series)
- Premium efficiency motors IE3
- Reduced backlash



C+BSR+DGM Series
In-line Gearmotors & Units
+ Decentralized Inverter
+ Reluctance motor

- Reliability and robustness
- Reduced standard backlash
- Minimized mounting space
- High efficiency packages (IE2 standard)
- Accurate sensorless speed control
- Motor frame reduction
- Perfect for retrofitting (same IEC motors mechanical dimensions)

- Thermal protection
- External mechanical protection
- Rotor balancing grade
- Wide range of field buses (Ethernet base or/and CANopen)
- STO operating safety option
- Synchronous Reluctance Motor IE4



BMD+SL Series
Synchronous Servomotors
+ In-Line Precision
Planetary Gearboxes

- Ultra-compact size
- High radial load capacity
- Positioning accuracy optimized for belt pulley drive systems
- Designed for continuous and intermittent duty

- Different feedback systems available
- Brake option
- Inertia flywheel
- Customized windings on request

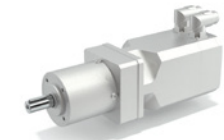

BMD+MP Series
Synchronous Servomotors
+ In-Line Precision
Planetary Gearboxes

- Modularity due to multiple design configurations
- Different optimized lubrications
- High precision and dynamic
- Highly compact

- Wide torque range up to 1000Nm
- Reinforced bearing option
- Different feedback systems available
- Brake option
- Inertia flywheel
- Customized windings on request



4

TERTIARY PACKAGING
PALLETIZING & WRAPPING MACHINES

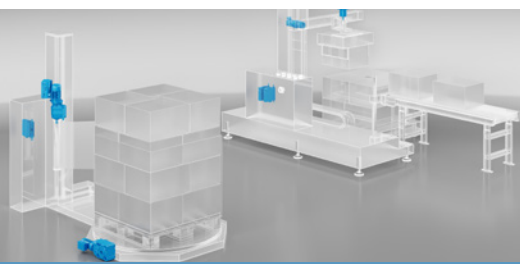

**ACTIVE CUBE
SERIES
PREMIUM INVERTER**



4

TERTIARY PACKAGING PALLETIZING & WRAPPING MACHINES

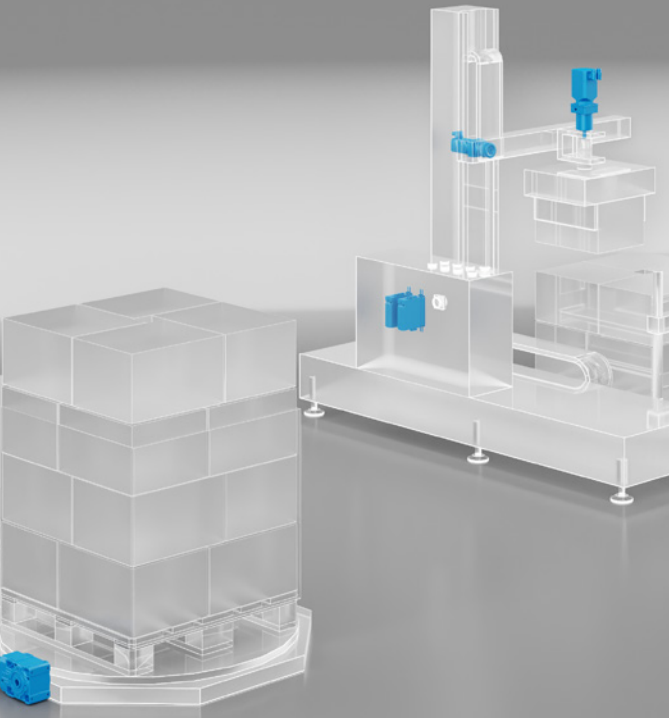

Active Cube Series Premium Inverter

BENEFITS

- Interpolated operating mode
- Smooth start
- Torque control

FEATURES

- Series optionally extendable for field bus communication and encoder evaluation
- Plug-in power terminals (up to 3kW)
- Plug-in and programmable control terminals
- DC link connection
- Integrated brake chopper
- Positioning function via field bus (motion control compatible to CiA DS402)
- Integrated VPLC
- Master/slave function with electronic gear
- Power failure control
- Integrated safe torque off STO (SIL 3 / PL e) function
- Output frequency 0...599 Hz, higher frequencies on request
- Diagnosis and setup via optional keypad or PC software

< BACK

1

PRIMARY PACKAGING
FLOW PACK MACHINES



3

TERTIARY PACKAGING
PALLETIZING MACHINES



4

TERTIARY PACKAGING
WRAPPING MACHINES



2

HANDLING
SMART CONVEYORS

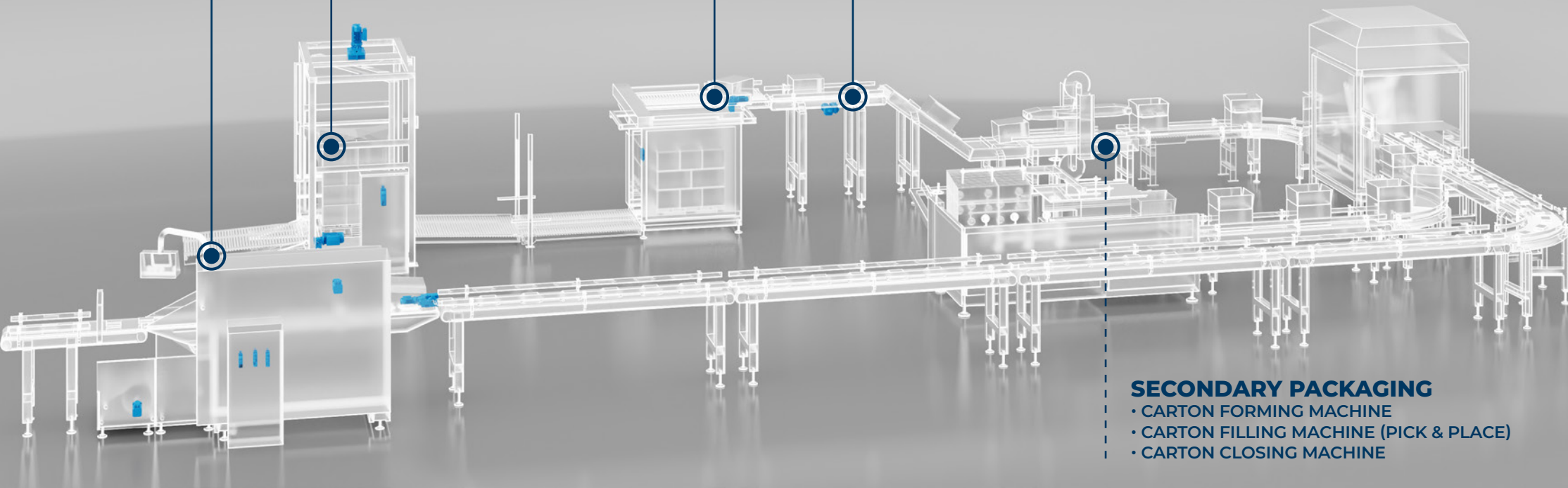

SECONDARY PACKAGING

- CARTON FORMING MACHINE
- CARTON FILLING MACHINE (PICK & PLACE)
- CARTON CLOSING MACHINE

1

PRIMARY PACKAGING
FLOW PACK MACHINES

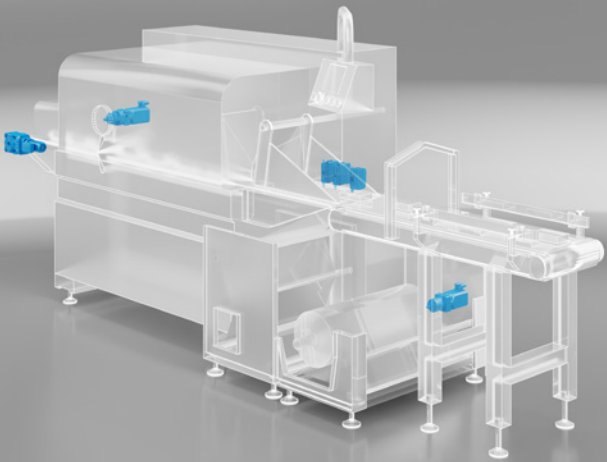

< **BACK**



A+MXN Series

Right angle Helical
Bevel Gearmotor +
Asynchronous Motor

BENEFITS

- Compact
- Universal mounting
- Modular design

FEATURES

- Keyed hollow shaft (metric and inch series)
- Premium efficiency motors IE3
- Reduced backlash

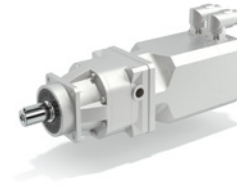

TQ+BMD Series

Precision Planetary
Gearbox + Permanent
Magnet Servo Motor

- High precision and dynamic
- Highly compact
- High stiffness
- Designed for continuous and intermittent duty

- Different feedback systems available
- Brake option
- Customized windings on request

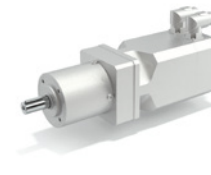

BMD+MP Series

Synchronous Servomotors
+ In-Line Precision
Planetary Gearboxes.

- Modularity due to multiple design configurations
- Different optimized lubrications
- High precision and dynamic
- Highly compact
- Sensorless control available

- Different feedback systems available
- Brake option
- Inertia flywheel
- Customized windings on request



**ACTIVE CUBE
SERIES**
PREMIUM INVERTER



ANG SERIES
SERVO INVERTER



AGILE SERIES
SMART INVERTER

1

PRIMARY PACKAGING
FLOW PACK MACHINES

< BACK



Active Cube Series
Premium Inverter



ANG Series
Servo Inverter



Agile Series
Smart Inverter

BENEFITS

- Interpolated operating mode
- Smooth start
- Torque control

- Interpolated mode
- Fast loop control
- 2 encoder inputs

- Low energy consumption
- Flexibility
- Preset values for Bonfiglioli motors to decrease commissioning times
- Very high power density
- Compactness
- Smart mounting to save space into the cabinet

FEATURES

- Series optionally extendable for field bus communication and encoder evaluation
- Plug-in power terminals (up to 3kW)
- Plug-in and programmable control terminals
- DC link connection
- Integrated brake chopper
- Positioning function via field bus (motion control compatible to CiA DS402)
- Integrated VPLC
- Master/slave function with electronic gear
- Power failure control
- Integrated safe torque off STO (SIL 3 / PL e) function
- Output frequency 0...599 Hz, higher frequencies on request
- Diagnosis and setup via optional keypad or PC software

- Different variants include field bus connection and encoder evaluation
- Plug-in power terminals (up to 3kW)
- Plug-in and programmable control terminals
- DC link connection
- Integrated brake chopper
- Positioning function via field bus (motion control compatible to CiA DS402)
- Cubic interpolation
- Integrated VPLC
- Master/slave function with electronic gear
- Power failure control
- Integrated safe torque off STO (SIL 3 / PL e) function
- Output frequency 0...599 Hz, higher frequencies on request
- Diagnosis and setup via optional keypad or PC software

- Series optionally extendable for field bus communication
- Sensorless synchronous and asynchronous motor control
- Modbus and Systembus onboard
- DC link connection
- Integrated brake chopper
- Power failure control
- Programmable PI controller
- Integrated VPLC
- Master/slave function with electronic gear
- Integrated safe torque off STO (SIL 2 / PL d) function
- Energy saving function
- Smart current limits
- Output frequency 0...599 Hz, higher frequencies on request
- Diagnosis and setup via integrated keypad and integrated service interface for PC connection

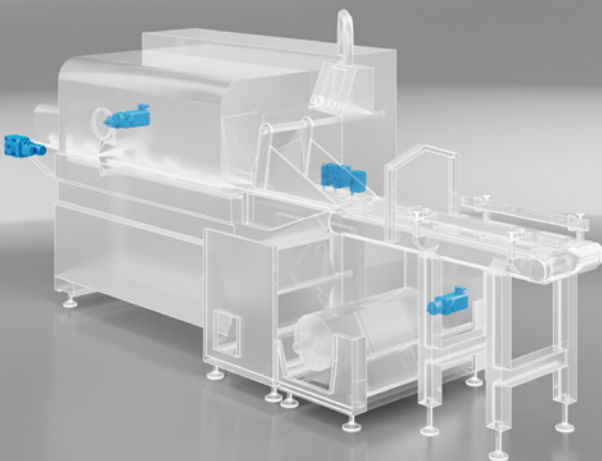

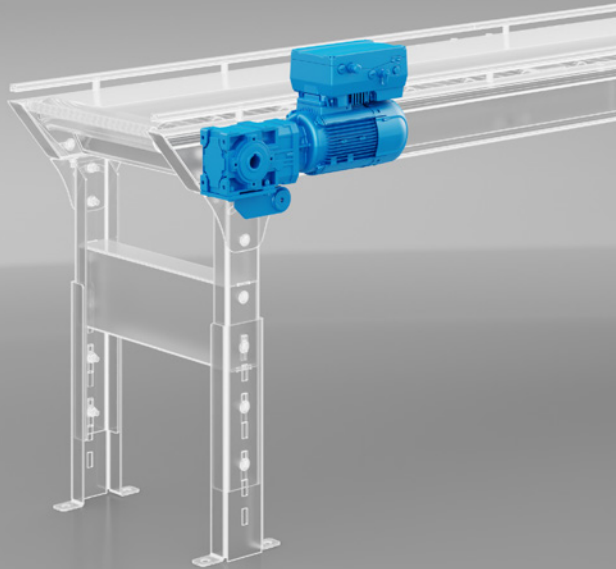

A Series

Right angle Helical Bevel Gearmotor

BENEFITS

- Torque density
- Compact design
- Wide speed choice

FEATURES

- Shaft mounting with hollow shaft and torque arm or shrink disk
- Horizontal or vertical mounting position
- Motor power from 0.37 to 11 kW
- Reinforced bearings available as option
- Reduced backlash as option

MX/BSR Series

Asynchronous Motor / Reluctance motor

- Torque density
- Compact design
- Wide speed choice
- Universal mounting position

- IE3/IE4 green solution
- High level of torque
- Wide range of options and flanges

DGM MPM Series

Decentralized Inverter

- Wide range of kW from 0.55 to 30kW
- Ethernet stack to manage with 1 product code: Profinet, Ethernet IP, Sercos3, Ethercat
- Motor's brake management

- IP65 Inverter
- Reduction of electrical wiring
- Management of Asynchronous motor, Reluctance Synchronous



3

TERTIARY PACKAGING PALLETIZING MACHINES

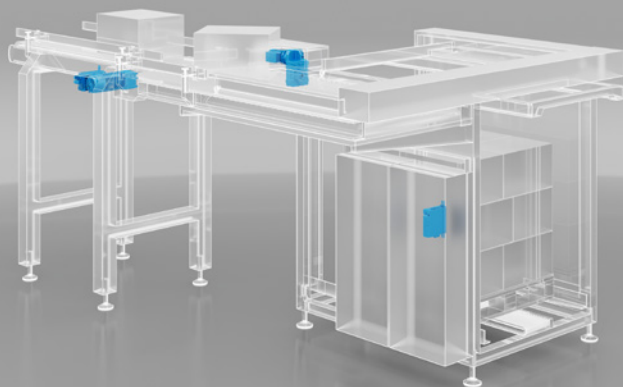

C+DGM+BXN Series

In-Line Gearboxes +
Asynchronous Motor +
Decentralized Inverter

BENEFITS

- Reliability and robustness
- Reduced standard backlash
- Minimized mounting space
- IE3 motor efficiency
- Torque density
- Wide speed choice

FEATURES

- IE3 green solution
- High level of torque
- Wide range of options and flanges
- Wide range of field buses (Ethernet base or/and CANopen)
- STO operating safety option



F+MXN Series

Helical Parallel-Shaft
Gearmotors & Units +
Asynchronous Motor

- Easy installation
- Low noise
- High torque capability

- Keyed Hollow Shaft - Two Bore Options per Size, Keyless Shrink Disc Fitting (Metric series)
- Keyed Hollow Shaft (Inch series)
- Backstop device
- High and premium efficiency motors (IE2, IE3)



Active Cube Series

Premium Inverter

- Interpolated operating mode
- Smooth start
- Torque control
- Load measurement and speed limit optimization

- Series optionally extendable for field bus communication and encoder evaluation
- Plug-in power terminals (up to 3kW)
- Plug-in and programmable control terminals DC link connection
- Integrated brake chopper
- Positioning function via field bus (motion control compatible to CiA DS402)
- Integrated VPLC
- Master/slave function with electronic gear
- Power failure control
- Integrated safe torque off STO (SIL 3 / PL e) function
- Output frequency 0...599 Hz, higher frequencies on request
- Diagnosis and setup via optional keypad or PC software

< BACK 

4

**TERTIARY PACKAGING
WRAPPING MACHINES**

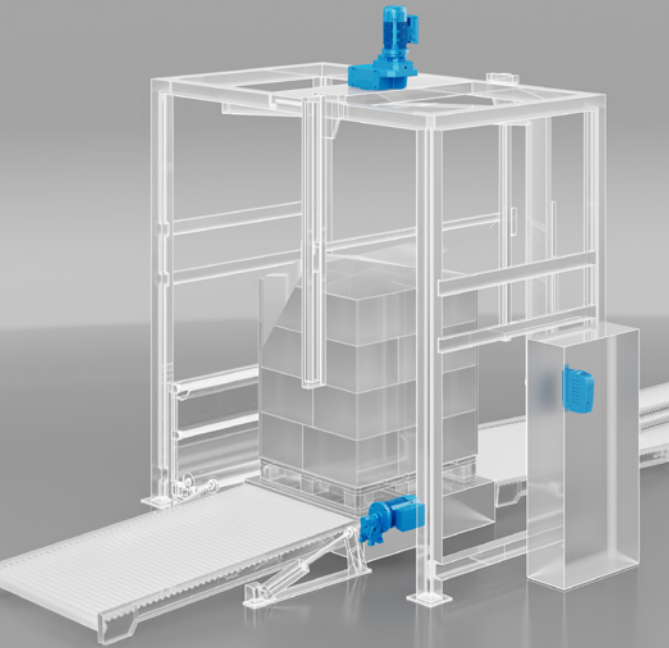

F+MXN Series
Helical Parallel-Shaft
Gearmotors & Units +
Asynchronous Motor

BENEFITS

- Easy installation
- Low noise
- High torque capability
- Flexibility

FEATURES

- Keyed Hollow Shaft - Two Bore
Options per Size, Keyless Shrink Disc
Fitting (Metric series)
- Keyed Hollow Shaft (Inch series)
- Backstop device
- High and premium efficiency motors
(IE2, IE3)



VF+MXN Series
Worm Gearmotors +
Asynchronous Motor

- Cost effective
- Uncompromising quality
- Compact design

- High and premium efficiency motors
IE3

< **BACK**



**AGILE SERIES
SMART INVERTER**



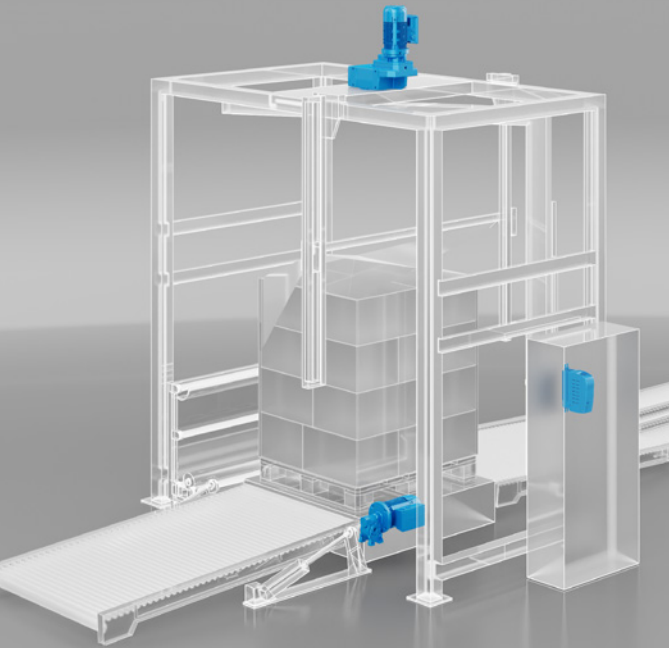

Agile Series

Smart inverter

BENEFITS

- Smooth start
- Feed roll control
- Low energy consumption

FEATURES

- Series optionally extendable for field bus communication
- Sensorless synchronous and asynchronous motor control
- Modbus and Systembus onboard
- DC link connection
- Integrated brake chopper
- Power failure control
- Programmable PI controller
- Integrated VPLC
- Master/slave function with electronic gear
- Integrated safe torque off STO (SIL 2 / PL d) function
- Energy saving function
- Smart current limits
- Output frequency 0...599 Hz, higher frequencies on request
- Diagnosis and setup via integrated keypad and integrated service interface for PC connection