

# ACTIVE CUBE

210/410/510/610 Series

Premium frequency inverters

 **Bonfiglioli**



# TABLE OF CONTENT

The highest level of precision, efficiency and energy optimization.....	4
A complete integrated solution for all industrial applications .....	5
Bonfiglioli Digital Tools.....	6
Bonfiglioli frequency inverters and servo drives.....	7
Active Cube Series .....	8
Applications.....	9
Active Cube system range .....	10
Active Cube key features and benefits .....	11
The designation of ACUx10 series .....	12
The order code of ACUx10 series.....	14
Hardware .....	16
Software.....	17
General Technical Data.....	18
ACU210   Technical data (from 0.25 to 3.0 kW).....	19
ACU210   Technical data (from 4.0 to 9.2 kW).....	20
ACU410   Technical data (from 0.25 to 3.0 kW).....	21
ACU410   Technical data (from 4.0 to 15 kW).....	22
ACU410   Technical data (from 18.5 to 65 kW).....	23
ACU410   Technical data (from 75 to 200 kW).....	24
ACUx10   Technical data (from 160 to 400 kW) .....	25
<b>Screen plates .....</b>	<b>26</b>
<b>Control terminals.....</b>	<b>27</b>
<b>Option modules.....</b>	<b>28</b>
Control unit   KP500.....	30
Interface   KP-USB.....	31
Communication Modules.....	32
System bus   EM-SYS module .....	33
Expansion module EM-IO-xx.....	34
Speed sensor modules EM-ENC-xx.....	36
Resolver Module EM-RES-01/EM-RES-02.....	38
Resolver Module EM-RES-03.....	39
Absolute encoder Module EM-ABS-01 .....	40
<b>Safe Torque Off (STO) .....</b>	<b>41</b>
<b>Mounting of standard devices .....</b>	<b>42</b>
Mounting of Size 1 .....	43
Mounting of Size 2.....	44
Mounting of Size 3.....	45
Mounting of Size 4.....	46
Mounting of Size 5.....	47
Mounting of Size 6.....	48
Mounting of Size 7 .....	49
Mounting of Size 8.....	50
<b>Input filter .....</b>	<b>51</b>
<b>Line choke.....</b>	<b>52</b>
<b>EMC filters.....</b>	<b>57</b>
<b>Backplate EMC filters .....</b>	<b>58</b>
<b>Book type EMC filters .....</b>	<b>60</b>
<b>Braking resistors.....</b>	<b>64</b>
<b>Global Presence.....</b>	<b>66</b>

# THE HIGHEST LEVEL OF PRECISION, EFFICIENCY AND ENERGY OPTIMIZATION

With more than 20 years of experience in creating tailored and forward-thinking motion control systems, Bonfiglioli has proven being a reliable partner as **one-stop shop for mechatronic applications** in industrial automation.

Bonfiglioli engineering specialists work side by side with customers to develop dedicated integrated solutions, covering the entire motion drive train according to an **Industry 4.0 approach**.

Thanks to the extensive know-how and the long-term collaboration with key customers, our two centers of excellence, located in Italy and Germany, develop **breakthrough mechatronic innovations**, including low backlash planetary gearboxes, servomotors, open and closed loop inverters, servo drives and energy regenerative units.

This, combined with a comprehensive range of **Professional Services**, enables us to respond to customers' requests by:

- providing **user friendly, plug & play solutions**
- **increasing** applications' **efficiency** and **productivity**
- designing **flexible, modular solutions** targeted to a wide range of applications
- granting access to real time data for **diagnostic, maintenance** and **predictive analytics**



ASSESSMENT &  
RECOMMENDATION



ENGINEERING &  
PLANNING



INSTALLATION &  
COMMISSIONING



RETROFIT &  
UPGRADE



MAINTENANCE &  
REPAIR

## Fully committed to the efficiency of customers' system over its life cycle

Bonfiglioli technical sales experts support customers with a proactive, flexible and dedicated approach **throughout the system's entire life cycle**.

- **Assessment and recommendation:** our team provides support starting from the very early stage of the project by assessing the requirements and developing a targeted analysis of the application, guiding customers in the choice of the most suitable components for their drive solution.
- **Engineering and planning:** our experts work with customers to co-engineer their application, offering consultancy in sizing, fine tuning and selecting the optimized drive train, always considering life cycle cost optimization.
- **Installation and commissioning:** we partner with our customers to ensure a quick, cost-effective and successful installation, optimizing the benefits and functions of their drive technology.
- **Retrofit and upgrade:** we update customers' machines with state-of-the-art technology to ensure constant levels of productivity, reliability and performance.
- **Maintenance and repair:** we work side by side with customers to avoid failures, reduce down times and ensure the best system operation.

# A COMPLETE INTEGRATED SOLUTION FOR ALL INDUSTRIAL APPLICATIONS

Our engineering specialists **work side by side with customers** to create the most effective solution, whether the request is to optimize an existing machine or to develop a new one. Our relationship with customers is based on an **active partnership** with fast decision-making processes to develop individually tailored offers. Our full-range and modular offering provides the necessary products for the development of vertically integrated solutions in **a variety of sectors**, such as material handling, automated storage, textile and packaging. Our team of experts assists customers in designing cost effective and energy efficient machines, aligning performance to meet the specific requirements.



## A COMPLETE INTEGRATED SOLUTION

- Precision Planetary Gearboxes
- Industrial Gearboxes
- Permanent Magnet Synchronous Motors
- Synchronous Reluctance Motors
- Asynchronous Motors
- Servo Drives
- Frequency Inverters
- Energy Regenerative Inverters
- Motion Control
- Industry 4.0 solutions

## INDUSTRY SECTOR EXPERTISE



# BONFIGLIOLI DIGITAL TOOLS

Thanks to a powerful set of **software tools** and **online platforms**, developed through partnerships with the main market leaders, Bonfiglioli enables its customers to **engineer tailored applications** in a smooth and productive way: the components selection and sizing, as well as the design of the whole motion drive train, are made simpler and more reliable.

In addition, thanks to its in-depth knowledge of industrial solutions, **Bonfiglioli engineering team is ready to assist customers** in their selection and design process, providing high quality technical support for specific application developments.



## SERVOSOFT | Develop optimized solutions

Bonfiglioli and SERVOSOFT® work together to **support customers in sizing complete multi-axis servo systems**, including motors, gearboxes and servodrives with 15 mechanisms and up to 50 axes in a shared bus or standalone configuration.

With the Bonfiglioli products available on SERVOSOFT, customers are able to select, size and design their customized and high performance applications.

In addition, the Bonfiglioli engineering team, thanks to its in-depth knowledge of the products, uses the high level servosizing tool SERVOSOFT® to provide a **top level customer support** service by developing **optimized, energy-efficient and tailored engineering solutions** to meet individual needs.



## MOSAICO | Product configuration and order assistant

Bonfiglioli's **complete e-business system** guides customers, distributors and agents through the process of **selecting the right product** for their specific needs, and provides support for **design activities** and **order management**, greatly accelerating the selection and ordering process and improving accuracy.

Thanks to this web-based technology, customers can get in touch with Bonfiglioli technical service any time from anywhere around the world.



## EPLAN | Enhance your electrical design

Bonfiglioli and EPLAN work together to **provide efficient engineering solutions**, aimed at reducing the gap between the initial concept and its development, programming and commissioning, thanks to:

- Always up-to-date device data and documentation
- Easy drag and drop function to develop optimized electrical drawings

# BONFIGLIOLI FREQUENCY INVERTERS AND SERVO DRIVES

## The right solution for a wide spectrum of applications

Our wide portfolio of frequency inverters and servo drives provides customers across a variety of sectors with **unprecedented levels of flexibility**, thanks to:

- the compatibility with a wide range of motors types
- scalable control performances from basic to demanding applications
- wide power range (from 0.25 to 1,200 kW)
- extensive input/output connectivity
- the support of major fieldbus protocols.

Whether in the textile industry, packaging, material working, automated storage or other sectors, our frequency inverters and servo drives are **optimized for numerous applications**.

Our team of experts constantly works with the aim of providing **innovative and highly performant solutions**, introducing continuous improvements in terms of better control of your processes, lower energy consumption, improved productivity and user experience.

## Highest energy efficiency

Our frequency inverters and servo drives portfolio fulfil the **highest IE2 efficiency class** in compliance with the **EN 61800-9-2 EcoDesign** regulation, for the reduction of energy consumption and the impact on the environment connected to industrial production.

Our drives give a major contribution to **energy consumption optimization and saving** to the entire plant. Several **incorporated functions** are available through parameter setup allowing to reduce the electrical energy needed to power motors, such as standby mode and automatic flux reduction.

## Top level user experience

All our drives provide **intuitive engineering software** and **user-friendly programming interfaces** for parameter setting, diagnostic and supported commissioning.

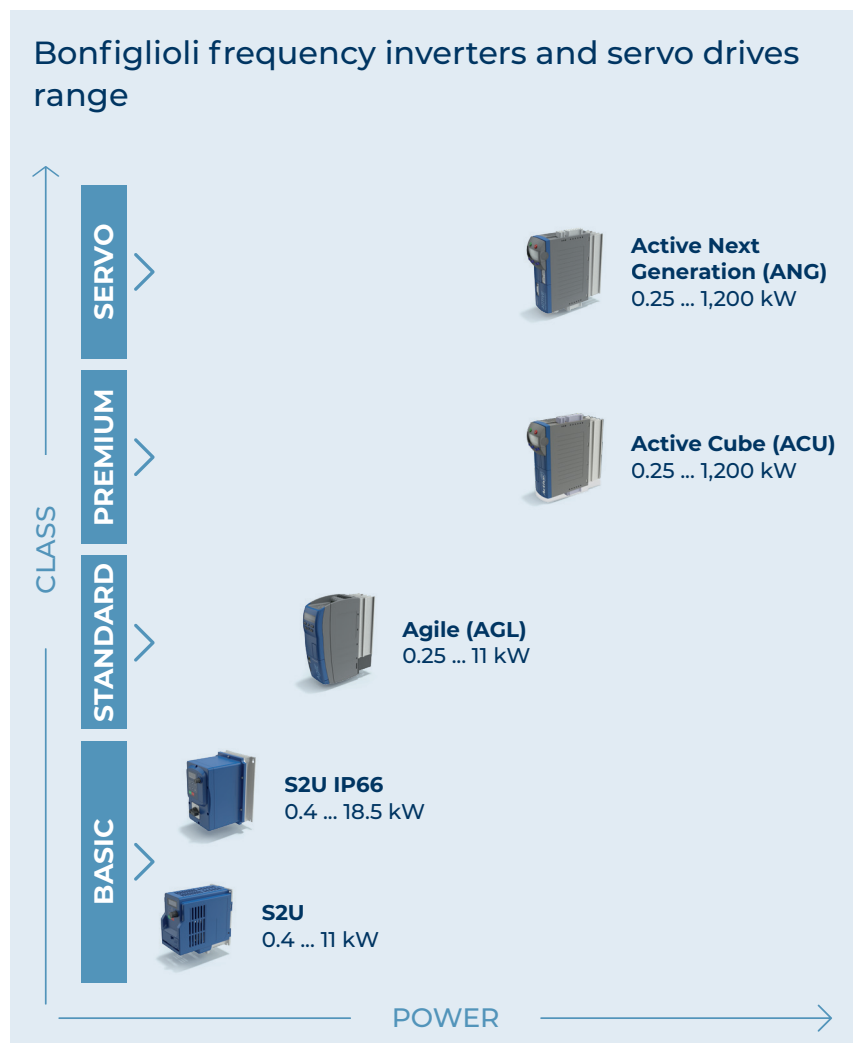

# ACTIVE CUBE SERIES

Active Cube (ACU) is the premium frequency inverter series offering a **modular set of features and options**, which make it suitable for a wide range of industrial applications.

With a **very wide power range** from 0.25 kW to 400 kW (with parallel connection of drives up to 1200 kW), several **optional modules for communication and expansion** for I/Os control and encoder evaluation, this series responds to the requirements of a variety of high performance applications, combining the **broadest connectivity** with the **most advanced control technology**.

For the integration into Functional Safety environments, ACU offers **Safe Torque Off (STO)** functionality according to SIL 3 and PL e.

The series include:

- 1 phase 230V mains: 0.25 - 4 kW
- 3 phase 230V mains: 0.25 - 9.2 kW
- 3 phase 400/480V mains: 0.25 - 400 kW
- 3 phase 525V mains: 160 - 400 kW
- 3 phase 690V mains: 160 - 400 kW



# APPLICATIONS

## The high-performance, dynamic and versatile solutions for a wide spectrum of applications

Whether in material working, hoists and cranes, automated storages, packaging, textile or food and beverage the frequency inverters of the Active Cube series are **optimized for numerous applications**. Active Cube size 8, in addition, provides a **powerful solution for typical heavy duty industries** such as mining, metal, water treatment and recycling.

Thanks to the **wide range of power sizes, mounting variants, optional communication and expansion modules**, the Active Cube series offers a **flexible solution** for machine design, allowing great freedom in the selection of the most suitable features and options.

In addition, the Active Cube series is characterized by **high compatibility with a wide range of motors types**: asynchronous, permanent magnet synchronous, synchronous reluctance, ensuring very **high precision in speed, torque and position**, both in **open and closed loop** operation.

Our offer expands far beyond standard, providing the right solutions tailored to the most demanding customers' requirements.

### RECYCLING



### HOISTS AND CRANES

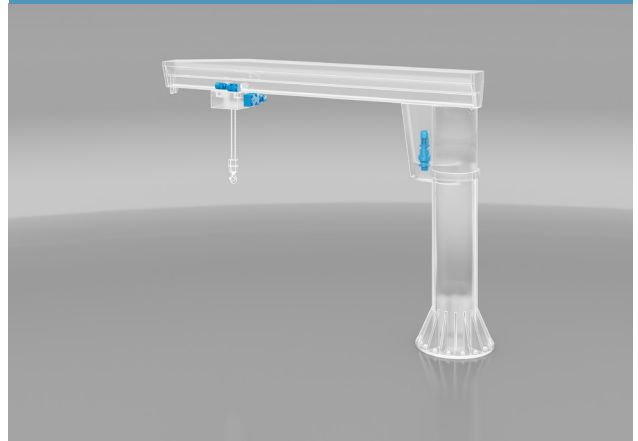

### AUTOMATED STORAGE

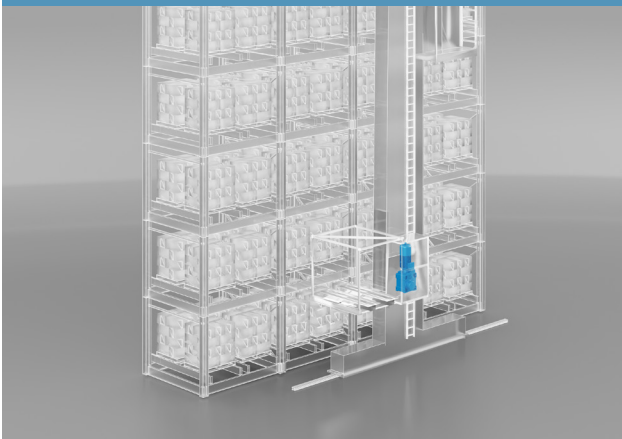

### TEXTILE

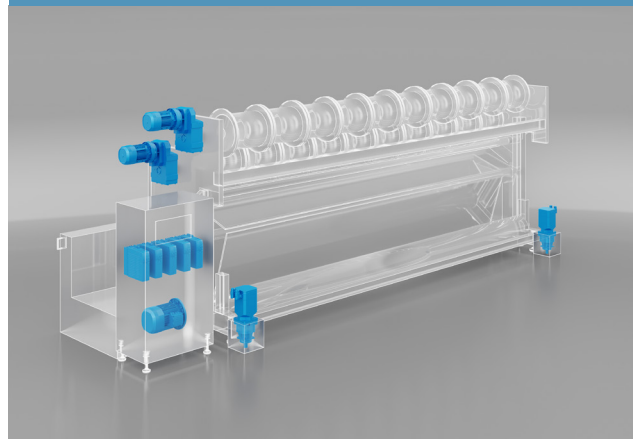

# ACTIVE CUBE SYSTEM RANGE

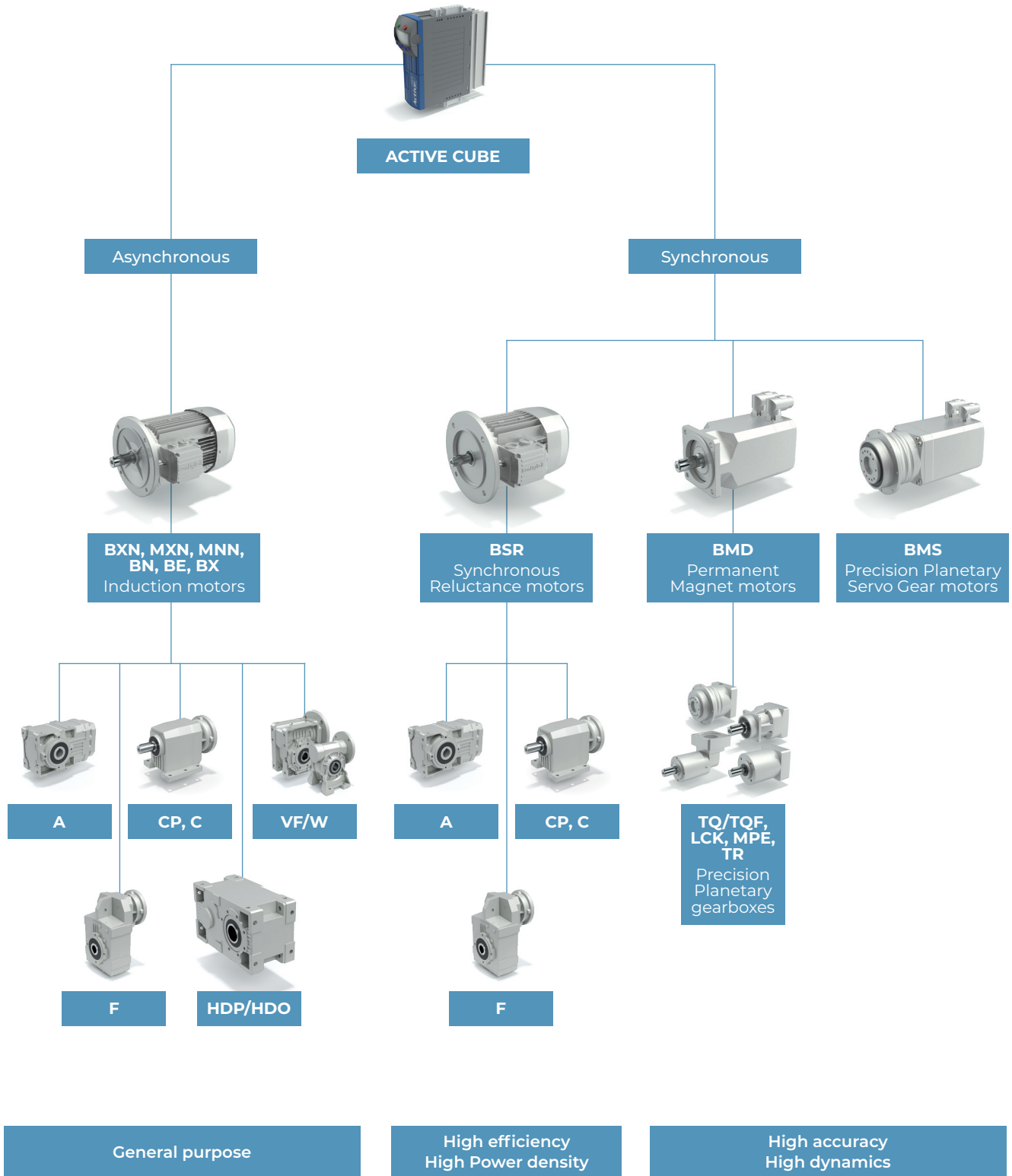

*This catalogue concerns Active Cube series and Active Cube accessories.  
For information about the other products showed in above overview, please refer to relevant catalogues.*



# ACTIVE CUBE KEY FEATURES AND BENEFITS



## APPLICATIONS FLEXIBILITY

Thanks to its **flexibility**, the system can be adapted to meet many different applications requirements by selecting the most suitable **options and accessories**.

The ACU series is designed for several applications including **heavy duty** and other demanding applications. The high power range **up to 1200 kW** offers different mounting concepts for high **mechanical flexibility**.

The **VPLC functions**, in addition, allow the **customization of the operational behavior**.



## ADVANCED CONTROL TECHNOLOGY

Active Cube offers several **embedded functionalities for advanced control**, such as brake control and controlled ramping down during mains failures (mains power failure management) and CiA402 features like Profile Position Mode, Profile Velocity and many more. Moreover, the single axis for the control of servo, asynchronous and synchronous reluctance motors delivers **high dynamic response, high performance and application versatility**.

This series also offers a **wide range** of supported **feedback sensors**.



## BROAD CONNECTIVITY

Smooth integration into automation networks thanks to the **compatibility with a wide range of fieldbus protocols** including CANopen, Profibus, EtherCAT, Profinet and more.



## WIDE POWER RANGE

The Active Cube frequency inverter series offers power ranges **from 0.25 to 400 kW**. Through parallel connection **1200 kW are achievable**.

The 525V and 690V supply voltages respond to the demanding requirements of the **heavy and steel industry**.



## USER FRIENDLY

The user-friendly **engineering software VPlus** provides an effective support for the **commissioning, tuning and monitoring** of the Active Cube frequency inverters **from a PC**. In addition, the optional **keypad** module is an **easy to use** tool to perform **setup and diagnosis** directly on the inverter.



## MODULARITY

**Several different communication and expansion modules** allow the fitting approach for the interface to the machine. Additional accessories like brake resistors, main chokes and filters supplement the product series for the fitting operation.



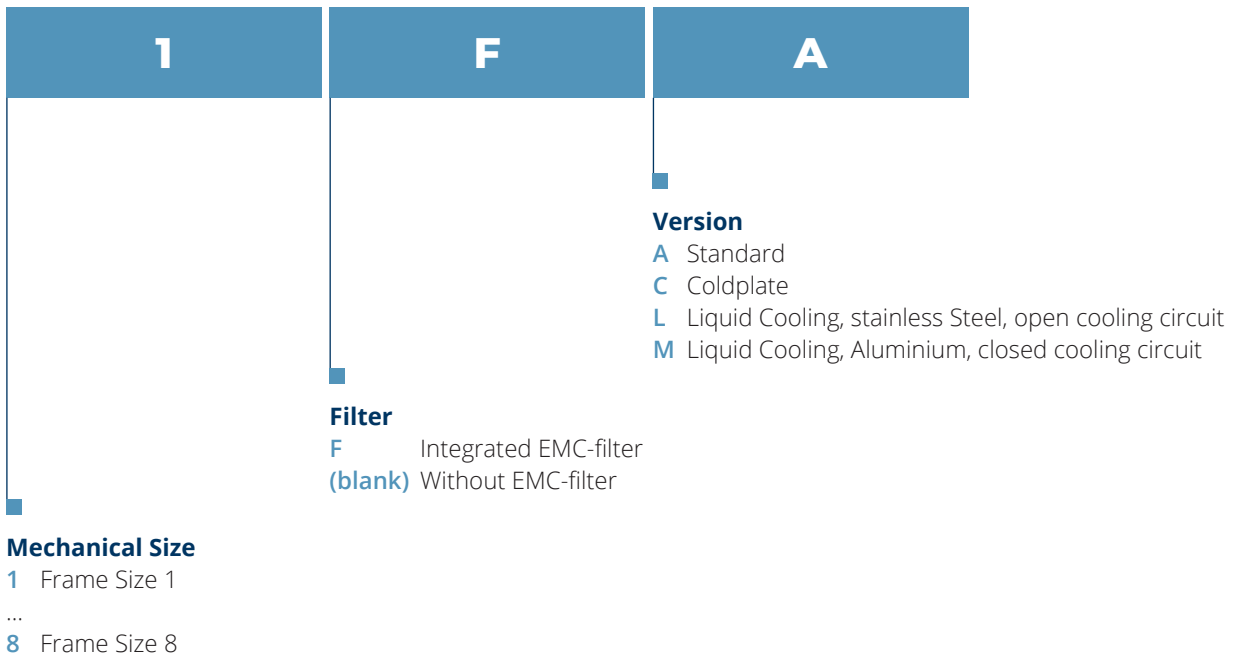





0 Reserved for future use (version with integrated EMC filter)  
 00 Reserved for future use (version without integrated EMC filter)

**Mains operation\***

W Usage in TN mains environments (Standard)  
 X Usage in IT mains environments or in combination with sinusoidal AEC mains units

**Functional Safety**

S STO (Safe Torque Off)

**Reserved**

X Reserved for future use

**Notes:**

(\*) In Sizes 1...4 the IT Bridge can be permanently removed by the user.

Sizes 5...8 have to be ordered according to the application requirements to receive the necessary modifications ex factory.



# HARDWARE

## Mounting and Cooling

- Standard Cabinet Mounting with Air Cooling (all mechanical sizes)
- ColdPlate Mounting (mechanical sizes 1...5)
- Liquid Cooling (mechanical sizes 5...8)
- DIN Rail mounting (mechanical sizes 1 & 2)
- Vibration resilient mounting kit for Air Cooling devices (mechanical sizes 1...6)

## Performance

- High speed control loop and fast response time
- Both “system drive” and “servo drive”
- Optimized combination with Bonfiglioli BMD servomotor and BSR synchronous reluctance motor series

## Automation

- Small dimensions and high power density in all sizes
- “Book shape” in smaller sizes for easy integration in automation cabinets
- External 24V<sub>DC</sub> supply input for control board supply from backup systems
- Motor thermal evaluation
- Position and speed feedback input (encoder/resolver)
- Encoder support with Expansion modules: TTL, HTL, Resolver, SinCos, Hiperface, EnDat 2.2 (with SinCos tracks), SSI

## Electrical

- Plug in control terminals for easy and fast connection
- Plug in power terminals up to 4 kW
- DC link bus for “energy sharing” in multidrive system architectures
- Integral EMC filters (EN 61800-3) up to 9.2 kW
- Integrated brake transistor on all sizes by default, sizes 6...8 available without brake transistor as option

## Options and accessories

- Optional expansion modules to increase the I/Os and feedback acquisition of the inverter
- Optional communication modules to connect Active Cube to control devices through Fieldbus connection
- Proprietary fieldbus (System bus) for fast communication among Bonfiglioli Active Cube drives
- Multifunction keypad with monitoring and programming functions
- Drive-PC connection kit for advanced configuration with engineering software VPlus
- Comprehensive power and control cable packs for fast and easy connection of Active Cube to Bonfiglioli BMD servomotors
- Compatible with Mains unit AEC allowing to feed back generative energy to the mains

## Functional Safety

- Safe Torque Off (STO)
- Safe Stop 1 (SS1 c) with Safety Switch
- SIL3 (EN61800-5-2) and PL e (EN ISO13849-1)

## Robustness

- Coated boards to enhance the device resilience <sup>(1)</sup>
- Vibration robustness according to DIN EN 60068-2-6: Test Fc and DIN EN 60068-2-27: Test Ea

(1) In Frame size 8 for some device a UPS (uninterrupted power supply) is internally equipped, where the boards are not coated. A UPS is included in 525 V and 690 V devices and devices marked with “X” for mains operations.

# SOFTWARE

## Flexibility

- Control of asynchronous motors, synchronous and synchronous reluctance motors (all with or without encoder feedback)
- Preset values for Bonfiglioli motors to decrease commissioning times
- Full set of operation modes, freely selectable:
  - Servo synchronous control with Resolver or Absolute encoder feedback (depending on option module)
  - Field oriented (vector) control with Absolute encoder or Incremental encoder
  - Sensorless field oriented (vector) and V/f control for all supported motor types
- Flexible assignment of digital inputs and outputs to interface with software and hardware functions
- “Motor chopper” function to increase braking power without brake resistors
- 4 independent data sets
- Flying restart

## Automation

- Easy and powerful engineering software for parameter setting, diagnostic and aided commissioning
- Integrated powerful logic functions
- Speed and position synchronization between drives through System bus
- Electronic gear with optional Phasing
- PI control with advanced derivative control
- Intelligent current limits
- Motor potentiometer control via digital input, control unit and communication interface

## Servo drive features

- Configurable position control and speed control via parameters
- Integrated motion software including homing functions and flying homing, units converter, programmable motion blocks to design and test even complex motion profiles
- Rotary table function
- S-ramps selection with separate adjustable acceleration/deceleration and jerk limitation
- Easy integration with CiA402 objects and functionality
- Auto-Tuning for angle determination (Resolver or absolute encoder) for Synchronous motors

## Safety

- Mains voltage monitoring and buffering function to overcome short time power failures
- Adjustable motor protection functions
- Overload protection and automatic best switching frequency adjustment

## Diagnosis

- Phase monitoring
- Mean and peak values storage
- Fault register (application and device)
- Optional Extension with Keypad and PC connection

## Advanced application functions

- Power failure management to ramp down in a controlled way
- Spindle control with “tool change” positioning
- “Traverse” function for winders
- “Index” function for enhanced sensorless synchronization
- Advanced brake release control (lifting applications)
- Load detection function

## Engineering software

- Extended Brake Control
- Easy programming interface
- Real time oscilloscope and variable values monitor for enhanced troubleshooting analysis
- Effective and easy management of motion block parameters
- A simple and guided procedure for set up with Bonfiglioli motors (asynchronous, synchronous, synchronous reluctance)
- Logic function programming section with 32 functions

# GENERAL TECHNICAL DATA

## Environment

### Operating conditions

- 0°C - 40°C (40°C - 55°C with derating)
- Pollution Degree 2
- Overvoltage Category III for mains connection
- Overvoltage Category III for relay connector circuit up to 2000 m
- Overvoltage Category II for relay connector circuit above 2000 m

### Environment class

- Operation 3K3 (EN60721-3-3)
- Relative humidity 15% ... 85%, no moisture condensation

### Altitude of installation

- Up to 1000m (up to 4000m with derating)

### Storage conditions

- According to EN50178

### Protection degree (EN 60529)

- IP20 with correctly mounted covers and connection terminals

### Environmental operation conditions according to DIN EN 60721-3-3:

- 3Z1 (negligible thermal radiation)
- 3B1 (no biological impact)
- 3C1 (chemically active substances, limits as per standard)
- 3S1 (mechanically active substances, no sand in air, limits as per standard)
- 3M4 (mechanical vibration and shocks, limits as per standard)

## Electrical

### Mains voltage operation

- ACU 210 in the range 184-0% ... 240 V+10%
- ACU 410 in the range 320-0% ... 480 V+10%
- ACU 510 with 525 V
- ACU 610 with 690 V

### Rated mains frequency

- 45 ... 66 Hz

### Overload current / Peak current

- 150 % Rated current for 60 s (200 % for 0.25 and 0.37 kW)
- 200 % Rated Current for 1 s for most ratings

### Electric protection

- Short circuit / Earth fault proof

### Braking transistor

- Built-in by default, optionally available without in mechanical sizes 6,7 & 8

## Standards

### CE conformity:

- 2014/35/EU (Low voltage directive)
- 2014/30/EU (Electromagnetic Compatibility Directive)
- 2011/65/EU (RoHS Directive)
- EN61800-5-1:2007 (Adjustable speed electrical power drive systems - Safety requirements - Electrical, thermal and energy)
- EN61800-3:2004 + A1:2012 (Adjustable speed electrical power drive systems - EMC requirements and specific test methods)

## Interference immunity

- According to EN 61800-3 for use in industrial environments

### UL/CSA approval:

- UL/CSA approval, according to UL508c/UL61800-5-1/CSA 22.2

# ACU210 | Technical data (from 0.25 to 3.0 kW)

ACU210-	01	03	05	07	09	11	13	15
			Size 1				Size 2	
Filter Variant:			F				F	
Mechanical Variants:			A, C				A, C	

## Output, motor side <sup>(1)</sup>

		01	03	05	07	09	11	13	15
Recommended rated motor power	P <sub>n</sub> kW	0.25	0.37	0.55	0.75	1.1	1.5	2.2	3.0
Rated motor current output	I <sub>n</sub> A	1.6	2.5	3.0	4.0	5.4	7.0	9.5	12.5 <sup>(1)</sup>
Rated motor voltage output	U <sub>n</sub> V	3 x (from 0 to mains voltage)							
Overload current (60 s)	I <sub>oc</sub> A	3.2	5.0	5.4	6.0	7.3	10.5	14.3	16.2
Peak current (1 s)	I <sub>pk</sub> A	3.2	5.0	6.0	8.0	8.0	14.0	19.0	19.0
Switching frequency	f <sub>c</sub> kHz	From 2 to 16 kHz (Default: 4 kHz)							
Output frequency	f <sub>n</sub> Hz	0 ... 599 Hz <sup>(2)</sup>							

## Input, mains side

		01	03	05	07	09	11	13	15
Rated mains voltage	U V	230							
Rated current 3 ph	I A	1.6	2.5	3.0	4.0	5.5 <sup>(4)</sup>	7.0	9.5	10.5 <sup>(4)</sup>
Recommended Mains fuses 3ph	I A	6	6	6	6	10	10	16	16
Rated current 1 ph/N; 2 ph	I A	2.9	4.5	5.4	7.2	9.5 <sup>(4)</sup>	13.2	16.5 <sup>(4)</sup>	16.5 <sup>(4)</sup>
Recommended Mains fuses 1 ph/N; 2ph	I A	6	10	10	10	16	16	20	20

## General

Connection Signal terminals <sup>(1)</sup>	A mm <sup>2</sup>	0.2 ... 1.5 (detachable terminals)								
Connection Power terminals <sup>(1)</sup>	A mm <sup>2</sup>	0.2 ... 1.5 (detachable terminals)								
Short circuit / ground fault protection	- -	Yes								
Mounting position	- -	Vertical								
Dimensions Standard Device	HxWxD mm	190 x 60 x 175					250 x 60 x 175			
Dimensions ColdPlate Device	HxWxD mm	190 x 82 x 140					250 x 85 x 140			
Weight (approx.)	m kg	1.2					1.6			
Brake chopper	- -	Internal brake chopper								
UL/CSA approval	- -	ul508c/CSA 22.2-No.14								

## Environment

Cooling temperature	T <sub>n</sub> °C	From 0 to 40							
Relative air humidity	- %	From 15 to 85, non-condensing							

## Options & accessories

Screen sheet for cable screens	- -	SCR1-2								
Pass through mounting kit	- -	MPVS1					MPVS2			
Increased Vibration mounting kit	- -	MNVIB1					MNVIB2			
DIN rail mounting kit	- -	MDIN1					MDIN2			
Input line choke	- -	External (depending on mains supply)								
EMC filter	- -	Internal Filter: Category C3 / External Filter or external choke: Category C2 / C1 <sup>(3)</sup>								

### Notes:

- (1) Please check the Operating Instructions for additional data
- (2) Higher frequencies available on request
- (3) For more details, please check the Input filter table in this catalogue
- (4) Continuous operation with rated current requires a line choke



# ACU210 | Technical data (from 4.0 to 9.2 kW)

ACU210-	18	19	21	22
	Size 3		Size 4	
Filter Variant:	F		-	
Mechanical Variants:	A, C		A, C	

## Output, motor side <sup>(1)</sup>

Recommended rated motor power	P <sub>n</sub>	kW	4.0	5.5	7.5	9.2
Rated motor current output	I <sub>n</sub>	A	18.0	22.0	32.0	35.0
Rated motor voltage output	U <sub>n</sub>	V	3 x (from 0 to mains voltage)			
Overload current (60 s)	I <sub>oc</sub>	A	26.3	30.3	44.5	51.5
Peak current (1 s)	I <sub>pk</sub>	A	33.0	33.0	64.0	64.0
Switching frequency	f <sub>c</sub>	kHz	From 2 to 16 kHz (Default: 4 kHz)			
Output frequency	f <sub>n</sub>	Hz	0 ... 599 Hz <sup>(2)</sup>			

## Input, mains side

Rated mains voltage	U	V	230			
Rated current 3 ph	I	A	18	20 <sup>(3)</sup>	28.2 <sup>(3)</sup>	35.6 <sup>(3)</sup>
Recommended Mains fuses	I	A	25		35	50

## General

Connection Signal terminals <sup>(1)</sup>	A	mm <sup>2</sup>	0.2 ... 1.5 (detachable terminals)			
Connection Power terminals <sup>(1)</sup>	A	mm <sup>2</sup>	0.2 ... 6		0.2 ... 16	
Short circuit / ground fault protection	-	-	Yes			
Mounting position	-	-	Vertical			
Dimensions Standard Device	HxWxD	mm	250 x 100 x 200		250 x 125 x 200	
Dimensions ColdPlate Device	HxWxD	mm	250 x 125 x 144		250 x 150 x 144	
Weight (approx.)	m	kg	3.0		3.7	
Brake chopper	-	-	Internal brake chopper			
UL/CSA approval	-	-	-		UL508c/CSA 22.2-No.14	

## Environment

Cooling temperature	T <sub>n</sub>	°C	From 0 to 40			
Relative air humidity	-	%	From 15 to 85, non-condensing			

## Options & accessories

Screen sheet for cable screens	-	-	SCR3		SCR4	
Pass through mounting kit	-	-	MPVS3		MPVS4	
Increased Vibration mounting kit	-	-	MNVIB3		MNVIB4	
Input line choke	-	-	External (depending on mains supply)			
EMC filter	-	-	For selection of EMC related components, please check the Input filter table in this catalogue			

### Notes:

- (1) Please check the Operating Instructions for additional data  
 (2) Higher frequencies available on request  
 (3) Continuous operation with rated current requires a line choke

# ACU410 | Technical data (from 0.25 to 3.0 kW)

ACU410-	01	03	05	07	09	11	12	13	15	
	Size 1				Size 2					
Filter Variant:	F				F					
Mechanical Variants:	A, C				A, C					

## Output, motor side <sup>(1)</sup>

		0.25	0.37	0.55	0.75	1.1	1.5	1.85	2.2	3.0
Recommended rated motor power	$P_n$ kW	0.25	0.37	0.55	0.75	1.1	1.5	1.85	2.2	3.0
Rated motor current output	$I_n$ A	1.0	1.6	1.8	2.4	3.2	3.8	4.2	5.8	7.8
Rated motor voltage output	$U_n$ V	3 x (from 0 to mains voltage)								
Overload current (60 s)	$I_{oc}$ A	2.0	3.2	2.7	3.6	4.8	5.7	6.3	8.7	11.7
Peak current (1 s)	$I_{pk}$ A	2.0	3.2	3.6	4.8	6.4	7.6	8.4	11.6	15.6
Switching frequency	$f_c$ kHz	From 2 to 16 kHz (Default: 4 kHz)								
Output frequency	$f_n$ Hz	0 ... 599 Hz <sup>(1)</sup>								

## Input, mains side

		0.25	0.37	0.55	0.75	1.1	1.5	1.85	2.2	3.0
Rated mains voltage	U V	400								
Rated current 3 ph	I A	1.0	1.6	1.8	2.4	2.8 <sup>(3)</sup>	3.3 <sup>(3)</sup>	4.2	5.8	6.8 <sup>(3)</sup>
Recommended Mains fuses	I A	6			6				10	

## General

Connection Signal terminals <sup>(1)</sup>	A mm <sup>2</sup>	0.2 ... 1.5 (detachable terminals)								
Connection Power terminals <sup>(1)</sup>	A mm <sup>2</sup>	0.2 ... 1.5 (detachable terminals)								
Short circuit / ground fault protection	- -	Yes								
Mounting position	- -	Vertical								
Dimensions Standard Device	HxWxD mm	190 x 60 x 175						250 x 60 x 175		
Dimensions ColdPlate Device	HxWxD mm	190 x 82 x 140						250 x 85 x 140		
Weight (approx.)	m kg	1.2						1.6		
Brake chopper	- -	Internal brake chopper								
UL/CSA approval	- -	ul508c/CSA 22.2-No.14								

## Environment

Cooling temperature	$T_n$ °C	From 0 to 40								
Relative air humidity	- %	From 15 to 85, non-condensing								

## Options & accessories

Screen sheet for cable screens	- -	SCR1-2								
Pass through mounting kit	- -	MPVS1						MPVS2		
Increased Vibration mounting kit	- -	MNVIB1						MNVIB2		
DIN rail mounting kit	- -	MDIN1						MDIN2		
Input line choke	- -	External (depending on mains supply)								
EMC filter	- -	Internal Filter: Category C3 / External Filter or external choke: Category C2 / C1 <sup>(4)</sup>								

### Notes:

(1) Please check the Operating Instructions for additional data

(2) Higher frequencies available on request

(3) Continuous operation with rated current requires a line choke

(4) For more details, please check the Input filter table in this catalogue



# ACU410 | Technical data (from 4.0 to 15 kW)

ACU410-	18	19	21	22	23	25
	Size 2		Size 3		Size 4	
Filter Variant:	F		- or F		-	
Mechanical Variants:	A, C		A, C		A, C	

## Output, motor side <sup>(1)</sup>

Recommended rated motor power	$P_n$	kW	4.0	5.5	7.5	9.2	11.0	15.0
Rated motor current output	$I_n$	A	9.0	14.0	18.0	22.0	25.0	32.0
Rated motor voltage output	$U_n$	V	3 x (from 0 to mains voltage)					
Overload current (60 s)	$I_{oc}$	A	13.5	21.0	26.3	30.3	37.5	44.5
Peak current (1 s)	$I_{pk}$	A	18.0	28.0	33.0	33.0	50.0	64.0
Switching frequency	$f_c$	kHz	From 2 to 16 kHz (Default: 4 kHz)					
Output frequency	$f_n$	Hz	0 ... 599 Hz <sup>(2)</sup>					

## Input, mains side

Rated mains voltage	U	V	400					
Rated current 3 ph	I	A	7.8 <sup>(3)</sup>	14.2	15.8 <sup>(3)</sup>	20.0 <sup>(3)</sup>	26.0	28.2 <sup>(3)</sup>
Recommended Mains fuses	I	A	10.0	16.0	25.0		35.0	

## General

Connection Signal terminals <sup>(1)</sup>	A	mm <sup>2</sup>	0. 2... 1.5 (detachable terminals)					
Connection Power terminals <sup>(1)</sup>	A	mm <sup>2</sup>	0.2 ... 1.5 (detachable terminals)	0.2 ... 6		0.2 ... 16		
Short circuit / ground fault protection	-	-	Yes					
Mounting position	-	-	Vertical					
Dimensions Standard Device	HxWxD	mm	250 x 60 x 175	250 x 100 x 200		250 x 125 x 200		
Dimensions ColdPlate Device	HxWxD	mm	250 x 85 x 144	250 x 125 x 144		250 x 150 x 144		
Weight (approx.)	m	kg	1.6	3.0		3.7		
Brake chopper	-	-	Internal brake chopper					
UL/CSA approval	-	-	ul508c/CSA 22.2-No.14					

## Environment

Cooling temperature	$T_n$	°C	From 0 to 40					
Relative air humidity	-	%	From 15 to 85, non-condensing					

## Options & accessories

Screen sheet for cable screens	-	-	SCR1-2	SCR3		SCR4		
Pass through mounting kit	-	-	MPVS2	MPVS3		MPVS4		
Increased Vibration mounting kit	-	-	MNVIB2	MNVIB3		MNVIB4		
DIN rail mounting kit	-	-	MDIN2	-		-		
Input line choke	-	-	External (depending on mains supply)					
EMC filter	-	-	For selection of EMC related components, please check the Input filter table in this catalogue					

### Notes:

- (1) Please check the Operating Instructions for additional data
- (2) Higher frequencies available on request
- (3) Continuous operation with rated current requires a line choke

# ACU410 | Technical data (from 18.5 to 65 kW)

ACU410-	27	29	31	33	35	37	39
		Size 5				Size 6	
Mechanical Variants:		A, C, L				A, L	
Brake Chopper Variant:		S				S, X	

## Output, motor side <sup>(1)</sup>

		27	29	31	33	35	37	39
Recommended rated motor power	P <sub>n</sub> kW	18.5	22.0	30.0	37.0	45.0	55.0	65.0
Rated motor current output	I <sub>n</sub> A	40.0	45.0	60.0	75.0	90.0	110.0	125.0
Rated motor voltage output	U <sub>n</sub> V	3 x (from 0 to mains voltage)						
Overload current (60 s)	I <sub>oc</sub> A	60.0	67.5	90.0	112.5	135.0	165.0	187.5
Peak current (1 s)	I <sub>pk</sub> A	80.0	90.0	120.0	150.0	180.0	220.0	250.0
Switching frequency	f <sub>c</sub> kHz	From 2 to 8 kHz (Default: 4 kHz) <sup>(5)</sup>						
Output frequency	f <sub>n</sub> Hz	0 ... 599 Hz <sup>(2)</sup>						

## Input, mains side

		27	29	31	33	35	37	39
Rated mains voltage	U V	400						
Rated current 3 ph	I A	42.0	50.0	58.0 <sup>(3)</sup>	87.0	104.0	105.0 <sup>(3)</sup>	120.0 <sup>(3)</sup>
Recommended Mains fuses	I A	50.0		63.0	100.0	125.0	125.0	

## General

Connection Signal terminals <sup>(1)</sup>	A mm <sup>2</sup>	0.2 ... 1.5 (detachable terminals)							
Connection Power terminals <sup>(1)</sup>	A mm <sup>2</sup>	... 25			... 70				
Short circuit / ground fault protection	- -	Yes							
Mounting position	- -	Vertical							
Dimensions Standard Device	HxWxD mm	250 x 200 x 260			400 x 275 x 260				
Dimensions ColdPlate Device	HxWxD mm	250 x 225 x 171			-				
Dimensions Liquid Cooling Device	HxWxD mm	480 x 300 x 220			480 x 300 x 208				
Weight Standard Device (approx.)	m kg	8.0			20.0				
Weight ColdPlate Device (approx.)	m kg	6.0			-				
Weight Liquid Cooling Device (approx.)	m kg	22.0			25.0				
Brake chopper	- -	Internal brake chopper			Internal brake chopper, optionally available without				
UL/CSA approval: Device series "A" & "C"	- -	ul508c/CSA 22.2-No.14							
UL/CSA approval: Device series "L"	- -	-							

## Environment

Cooling temperature <sup>(4)</sup>	T <sub>n</sub> °C	From 0 to 40						
Relative air humidity	- %	From 15 to 85, non-condensing						

## Options & accessories

Screen sheet for cable screens	- -	SCR5			-			
Pass through mounting kit	- -	MPVS5			MPVS6			
Increased Vibration mounting kit	- -	MNVIB5			MNVIB6			
Input line choke	- -	External (depending on mains supply)						
EMC filter	- -	For selection of EMC related components, please check the Input filter table in this catalogue						

### Notes:

(1) Please check the Operating Instructions for additional data

(2) Higher frequencies available on request

(3) Continuous operation with rated current requires a line choke

(4) When using Liquid Cooling devices, please check the Additional Operating Instructions for Liquid Cooling

(5) Higher Switching frequencies available on request



# ACU410 | Technical data (from 75 to 200 kW)

ACU410-	43	45	47	49	51	53 <sup>(4)</sup>
				Size 7		
Mechanical Variants:				A, L		
Brake Chopper Variant:				S, X		

## Output, motor side<sup>(1)</sup>

		75	90	110	132	160	200
Recommended rated motor power	$P_n$ kW	75	90	110	132	160	200
Rated motor current output	$I_n$ A	150	180	210	250	305	380
Rated motor voltage output	$U_n$ V	3 x (from 0 to mains voltage)					
Overload current (60 s)	$I_{oc}$ A	225	270	315	332	460	570
Peak current (1 s)	$I_{pk}$ A	270	325	375	375	550	680
Switching frequency	$f_c$ kHz	From 2 to 8 kHz (Default: 4 kHz) <sup>(7)</sup>					
Output frequency	$f_n$ Hz	0 ... 599 Hz <sup>(2)</sup>					

## Input, mains side

		143 <sup>(5)</sup>	172 <sup>(5)</sup>	208 <sup>(5)</sup>	249 <sup>(5)</sup>	302 <sup>(5)</sup>	377 <sup>(5)</sup>
Rated mains voltage	U V	400					
Rated current 3 ph	I A	143 <sup>(5)</sup>	172 <sup>(5)</sup>	208 <sup>(5)</sup>	249 <sup>(5)</sup>	302 <sup>(5)</sup>	377 <sup>(5)</sup>
Recommended Mains fuses	I A	160	200	250	315	400	500

## General

Connection Signal terminals <sup>(1)</sup>	A mm <sup>2</sup>	0.2 ... 1.5 (detachable terminals)					
Connection Power terminals <sup>(1)</sup>	A mm <sup>2</sup>	... 2x95			... 2x120		
Short circuit / ground fault protection	- -	Yes					
Mounting position	- -	Vertical					
Dimensions <sup>(3)</sup>	HxWxD mm	510 x 412 x 351				510 x 412 x 389	
Weight (approx.)	m kg	48		48		52	
Brake chopper	- -	Internal brake chopper, optionally available without					
UL/CSA approval: Device series "A"	- -	ul508c/CSA 22.2-No.14				-	
UL/CSA approval: Device series "L"	- -	-				-	

## Environment

Cooling temperature <sup>(6)</sup>	$T_n$ °C	From 0 to 40					
Relative air humidity	- %	From 15 to 85, non-condensing					

## Options & accessories

Pass through mounting kit	- -	MPVS7					
Input line choke	- -	External (depending on mains supply)					
EMC filter	- -	For selection of EMC related components, please check the Input filter table in this catalogue					

### Notes:

(1) Please check the Operating Instructions for additional data

(2) Higher frequencies available on request

(3) Dimensions are the same for Standard and Liquid

(4) -53 is available as Liquid Cooling device

(5) Operation requires a line choke

(6) When using Liquid Cooling devices, please check the Additional Operating Instructions for Liquid Cooling

(7) Higher Switching frequencies available on request

# ACUX10 | Technical data (from 160 to 400 kW)

ACU410-/510-/610-	51	53	55	57	59	61
	<b>Size 8</b>					
Mechanical Variants:	A, L, M, N					
Brake Chopper Variant:	S, X					

## Output, motor side <sup>(1)</sup>

			160	200	250	315	355	400
Recommended rated motor power	$P_n$	kW	160	200	250	315	355	400
Rated motor current output	$I_n$	A	305	380	475	595	645	735
ACU410 Long-term overload current (60s)	$I_{oc}$	A	460	570	715	895	970	1100
Short-term overload current (1s)	$I_{pk}$	A	550	685	855	1070	1160	1330
Rated motor current output	$I_n$	A	230	290	360	450	490	560
ACU510 Long-term overload current (60s)	$I_{oc}$	A	345	435	540	675	735	840
Short-term overload current (1s)	$I_{pk}$	A	420	520	650	810	880	1000
Rated motor current output	$I_n$	A	180	230	280	350	400	450
ACU610 Long-term overload current (60s)	$I_{oc}$	A	270	350	420	530	600	675
Short-term overload current (1s)	$I_{pk}$	A	330	420	510	630	720	810
Rated motor voltage output	$U_n$	V	Maximum input voltage, three-phase					
Switching frequency	$f_c$	kHz	From 2 to 8 kHz (Default: 4 kHz) <sup>(6)</sup>					
Output frequency	$f_n$	Hz	0 ... 599 Hz					

## Input, mains side

			400					
ACU410 Rated mains voltage	U	V	400					
Rated current 3 ph <sup>(2)</sup>	I	A	280 <sup>(4)</sup>	350 <sup>(4)</sup>	440 <sup>(4)</sup>	550 <sup>(4)</sup>	620 <sup>(4)</sup>	690 <sup>(4)</sup>
Recommended Mains fuses 3 ph <sup>(3)</sup>	I	A	400	500	630	700	800	900
Rated mains voltage	U	V	525					
ACU510 Rated current 3 ph <sup>(2)</sup>	I	A	215 <sup>(4)</sup>	270 <sup>(4)</sup>	335 <sup>(4)</sup>	420 <sup>(4)</sup>	470 <sup>(4)</sup>	525 <sup>(4)</sup>
Recommended Mains fuses 3 ph <sup>(3)</sup>	I	A	315	350	450	550	630	700
Rated mains voltage	U	V	690 (reduced for UL: 600)					
ACU610 Rated current 3 ph <sup>(2)</sup>	I	A	160 <sup>(4)</sup>	200 <sup>(4)</sup>	250 <sup>(4)</sup>	320 <sup>(4)</sup>	360 <sup>(4)</sup>	410 <sup>(4)</sup>
Recommended Mains fuses 3 ph <sup>(3)</sup>	I	A	252	315	350	450	500	550

## General

Connection Signal terminals <sup>(1)</sup>	A	mm <sup>2</sup>	0.2 ... 1.5 (detachable terminals)					
Connection Power terminals <sup>(1)</sup>	A	mm <sup>2</sup>	... 2x240					
Short circuit / ground fault protection <sup>(3)</sup>	-	-	Yes					
Mounting position	-	-	Vertical					
Dimensions	HxWxD	mm	1063 x 439 x 375					
Weight (approx.)	m	kg	120	120	120	140	140	140
Brake chopper	-	-	Internal brake chopper, optionally available without					
UL/CSA approval	-	-	ACU410: UL 61800-5-1/CSA 22.2   ACU510 & 610: -					

## Environment

Cooling temperature <sup>(5)</sup>	$T_n$	°C	-25 ... 45					
Relative air humidity	-	%	From 15 to 85, non-condensing					

## Options & accessories

Input line choke	-	-	External (depending on mains supply)					
EMC filter	-	-	For selection of EMC related components, please check the Input filter table in this catalogue					

### Notes:

- (1) Please check the Operating Instructions for additional data
- (2) Related value with recommended motor power, rated mains voltage and mains inductance  $U_L=4\%$
- (3) Semiconductor fuses recommended (in example Bussmann Type 170M)
- (4) Operation requires a line choke
- (5) When using Liquid Cooling devices, please check the Additional Operating Instructions for Liquid Cooling
- (6) Higher Switching frequencies available on request



# SCREEN PLATES

SCR1-2, SCR3, SCR4, SCR5

For the mechanical sizes 1 to 5 screen plates are available for the mounting of electrical cable screens.



# CONTROL TERMINALS

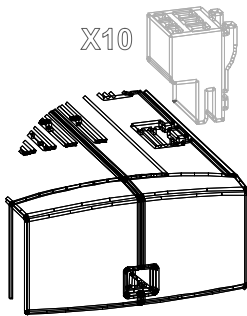
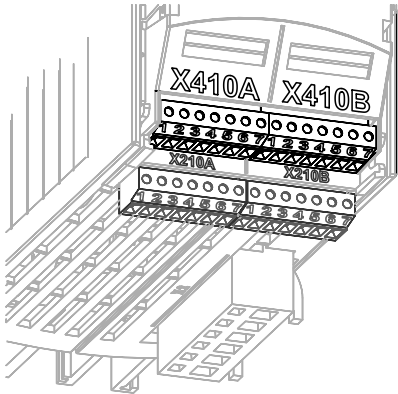

## Control terminal X210A

X210A.1	Voltage output DC +20 V or input for external power supply DC 24 V $\pm 10\%$
X210A.2	GND 20 V/ GND 24 V (ext.)
X210A.3	Digital Input STOA (first shut-down path)
X210A.4	Digital input <sup>(1)</sup> Start Clockwise (default setting)
X210A.5	Digital input <sup>(1)</sup> Start Anticlockwise (default setting)
X210A.6	Digital input <sup>(1)</sup> Data Set Changeover 1 (default setting)
X210A.7	Digital input <sup>(1)</sup> Data Set Changeover 2 (default setting)

## Control terminal X210B

X210B.1	Digital input <sup>(1)</sup>
X210B.2	Digital input STOB (second shut-down path)
X210B.3	Digital Output <sup>(1)</sup> Run Signal (default setting)
X210B.4	MFO1: Multifunction output <sup>(1)</sup> (voltage signal, proportional actual frequency, default setting)
X210B.5	Supply voltage DC +10 V for reference value potentiometer, ( $I_{max}=4$ mA)
X210B.6	MFI1: Multifunction input <sup>(1)</sup> 0V ... +10V, PT1000/KTY, 0 ... 20 mA
X210B.7	Ground 10 V

## Relay output X10

S3OUT	Relay output <sup>(1)</sup>
	Make Contact: AC 5 A / 240 V, DC 5 A (ohmic) / 24 V Break Contact: AC 3 A / 240 V, DC 1 A (ohmic) / 24 V

(1) Control terminals are freely configurable.

## Control terminal X410A

X410A.1	Depends on selected Expansion module
X410A.2	Depends on selected Expansion module
X410A.3	Depends on selected Expansion module
X410A.4	Depends on selected Expansion module
X410A.5	Depends on selected Expansion module
X410A.6	Depends on selected Expansion module
X410A.7	Depends on selected Expansion module

## Control terminal X410B

X410B.1	Depends on selected Expansion module
X410B.2	Depends on selected Expansion module
X410B.3	Depends on selected Expansion module
X410B.4	Depends on selected Expansion module
X410B.5	Depends on selected Expansion module
X410B.6	Depends on selected Expansion module
X410B.7	Depends on selected Expansion module

# OPTION MODULES

Active Cube is designed to give the highest flexibility in drive hardware to suit every control requirement. Machine designers can select from an extensive range of possible expansion hardware modules that can be fitted directly into the 3 available slots on the standard Active Cube unit. Mounting and connection is fast and easy thanks to onboard fastening devices.

Using option modules, Active Cube features and integration ability can be greatly expanded: the number of possible hardware configurations offers solutions for a wide variety of requirements and applications.

Build the best hardware configuration of Active Cube for your machine!

## Hardware modularity



### Interface module

Connection of optional control unit KP500, PC interface adapter KP-USB, or the control unit remote cable for accessory KPCMK

## Hardware modularity



### CM communication module

Connection panel for various communication protocols:

- CM-232, RS232 interface
- CM-485, RS485 interface
- CM-PDPV1, Profibus DP V1 interface
- CM-CAN, CANopen interface
- CM-DEV, DeviceNet interface
- CM2-EtherCAT®, EtherCAT® interface
- CM2-PNC, Profinet compatible interface
- CM2-Modbus/TCP, Modbus/TCP interface
- CM2-VABus/TCP, Ethernet VABus/TCP interface
- Other protocols on request

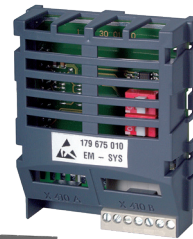





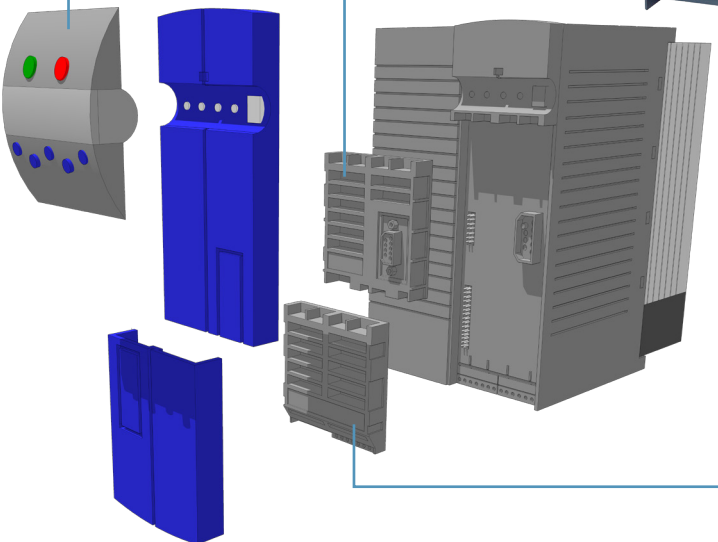

### EM expansion module

Connection panel for adaptation of control inputs and outputs to the various applications on the basis of specific machine requirements:

- EM-IO, analog and digital inputs and outputs, available in 4 variants
- EM-ENC, encoder interface, frequency output and system bus, available in 5 variants
- EM-RES, resolver interface, frequency output and system bus, available in 3 variants
- EM-SYS, system bus communication
- EM-ABS, absolute encoder module
- Other customised modules available on request



Option modules can be ordered either separately or together with ACU base unit, as an “extended” power package. The majority of Active Cube option modules can also be used in the Active series, thus allowing drives from both series to be easily used in the same automation system. Select from below the hardware module to customize Active Cube and build a unique drive which best fits to the needs of your application.

		AI	AO	DI	DO	RELAY	RF	Speed encoder		System Bus
								Type (s)	Zero pulse	
<b>Basic equipment of Active Cube</b>		1 <sup>(2)</sup>	-	6 <sup>(3)</sup>	1	1	-	HTL	yes	-
	EM-IO-01	1	1	3	-	2	-	HTL	yes	yes
	EM-IO-02	1	1	3	-	1	-	HTL	yes	yes
	EM-IO-03	1	2	2	-	1	-	HTL	no	yes
	EM-IO-04	-	-	2	1 <sup>(1)</sup>	-	-	-	-	yes
	EM-ENC-01	1	-	-	-	-	yes <sup>(5)</sup>	TTL & HTL	no	yes
	EM-ENC-02	1	1	-	1 <sup>(1)</sup>	-	-	TTL & HTL	no	yes
	EM-ENC-03	-	-	-	-	-	-	TTL & HTL	no	yes
	EM-ENC-04	1	1	-	-	1	-	TTL & HTL	yes	no
	EM-ENC-05	1	1	-	-	-	-	TTL & HTL	yes	yes
	EM-RES-01	1	-	-	-	-	yes <sup>(5)</sup>	Resolver		yes
	EM-RES-02	1	-	-	-	-	yes <sup>(6)</sup>	Resolver		no
	EM-RES-03	1	-	3	2	-	-	Resolver <sup>(4)</sup>		yes
	EM-SYS	-	-	-	-	-	-	-	-	yes
	EM-ABS-01	1	-	3	2	-	yes <sup>(5)</sup>	SinCos, SSI, Hiperface, EnDat 2.2 with SinCos tracks		yes

1) Can be used as digital input alternatively

2) MF1 can be used as digital input alternatively

3) One DI is used for control enable. HTL encoder evaluation possible.



4) EM-RES-03: Resolver and PTC are run through a DSub 9 connector.

5) Repetition frequency without Zero Pulse

6) Repetition frequency with Zero Pulse

RF: Repetition frequency, speed sensor simulation.

All inputs/outputs are realized with disconnectable terminals

Communication		
	CM-CAN	Connectors realized with DSUB-9 connector
	CM-PDPV1	
	CM-485	
	CM-232	
	CM-CAN-T	Bus connection via Spring-type terminal
	CM-PDPV1-T	
CM-485-T		
	CM-DEV	
	CM2-EtherCAT	EtherCAT module with 2 usable RJ45 ports
	CM2-PNC	PROFINET compatible module with 1 usable RJ45 port
	CM2-Ethernet/IP	Ethernet/IP module with 1 usable RJ45 port
	CM2-Modbus/TCP	Modbus/TCP module with 1 usable RJ45 port
	CM2-VABus/TCP	VABus/TCP module with 1 usable RJ45 port

# CONTROL UNIT | KP500



Active Cube is designed to give the highest flexibility in drive hardware to suit every control requirement. Machine designers can select an optional Keypad for diagnosis or parameterization independent from a Personal Computer. An optional remote unit gives the possibility to mount the keypad on a cabinet door or convert a keypad into a handheld.



Control unit remote installation kit / KPCMK  
The KPCMK kit is used to remotely control the inverter from the KP500 unit.

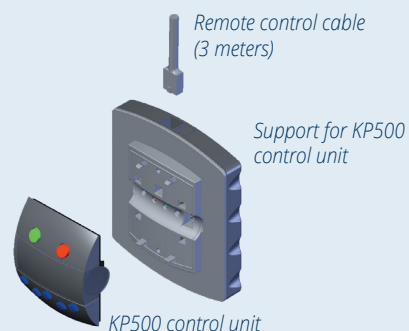

Handheld remote control unit

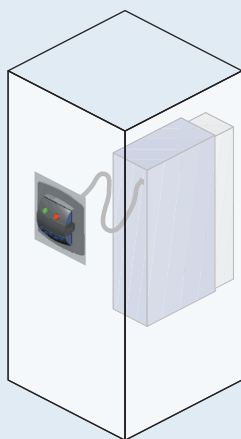

Remote installation on exterior of enclosure

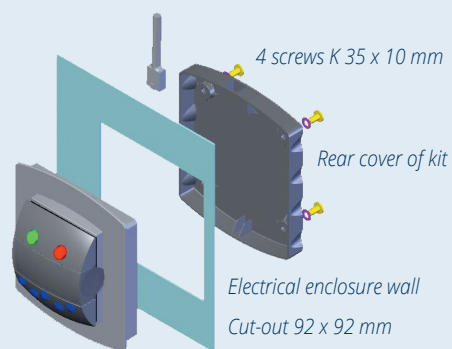

Fixing to enclosure

## INTERFACE | KP-USB

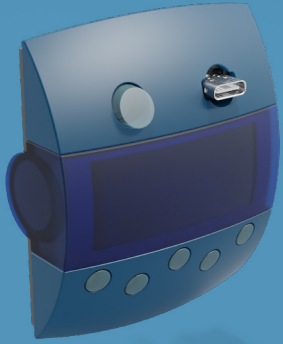

The KP-USB adapter can be used as an alternative to control unit KP500. This connection enables parameterisation, monitoring, setting management, inverter control and even commissioning from a PC or laptop computer. The USB point-to-point connection allows in an easy way the connection between inverter series ACTx10/ACUx10/ANGx10 and PC.

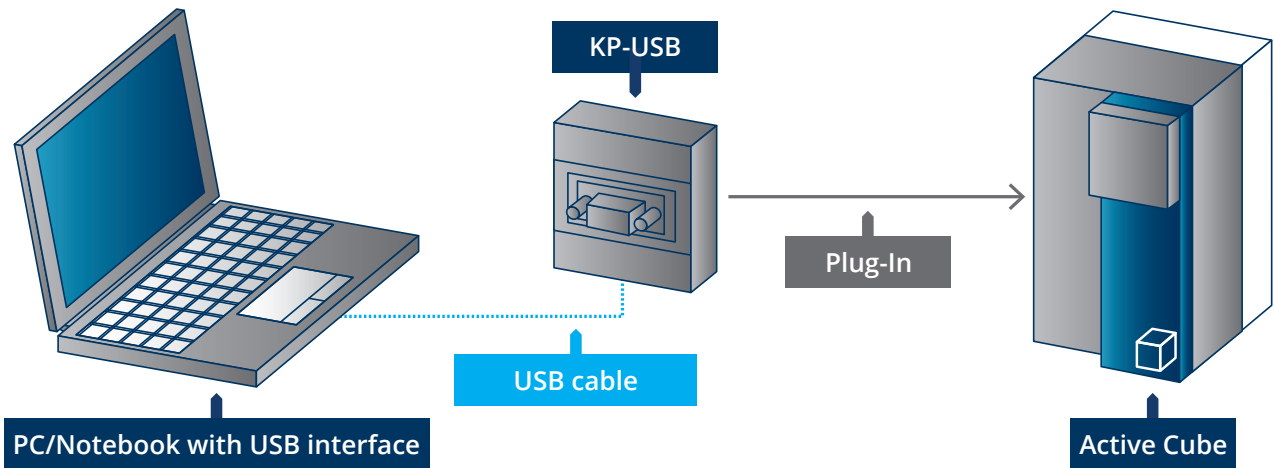

# COMMUNICATION MODULES

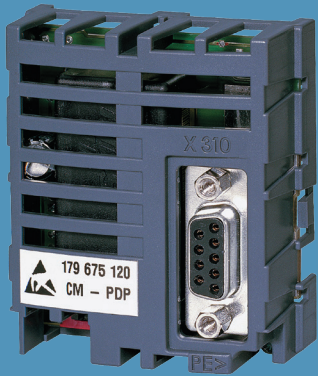

For integration into fieldbus networks you can install an optional module with an additional network interface. Active Cube inverters can therefore be integrated into existing fieldbus networks simply by adapting inverter communications to the hardware and software of the existing communications standard.

Active Cube inverters share the same communication module platform with other Bonfiglioli inverter series like Agile reducing stock costs when using different Bonfiglioli inverter series. They also profit from the same plug & play functionality, so that the inverter recognises and enables the new module automatically as soon as it is powered on.

Active Cube inverters support various communication standards with option modules. See the table alongside.

All optional modules are identical in shape and size, but differ in electronic functioning according to the standards of the type of field bus they communicate with.

Communication modules are installed in slots in the front of the inverter. Simply remove the protective cover to access the slots. A secure push-fit ensures an efficient electrical connection.

With the front panel removed, the connector (typically DSUB-9 or RJ45) for the communication module is also accessible.

Field bus	Optional module
CANopen	CM-CAN
Profibus DP V1	CM-PDP-V1
RS232	CM-232
RS485 Modbus	CM-485
DeviceNet	CM-DeviceNet
EtherCAT	CM2-EtherCAT
Profinet	CM2-PNC
Ethernet	CM2-Ethernet/IP
Modbus/TCP	CM2-Modbus/TCP
VABus/TCP	CM2-VABus/TCP

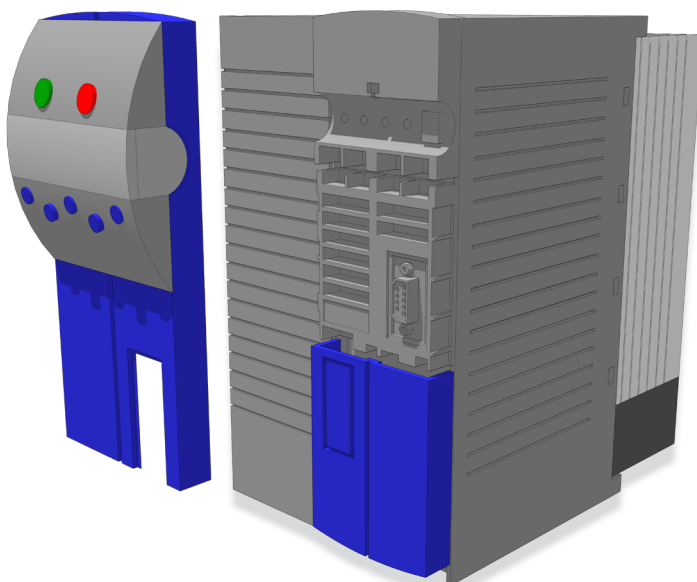

CANopen®

PROFI®  
BUS

EtherCAT®

PROFI®  
NET

# SYSTEM BUS | EM-SYS MODULE



The System bus of Active Cube inverters is a proprietary communication bus, based on CANopen protocol that allows fast exchange of data between the inverters and access, by a system bus master, to the parameters of all devices connected on the network. The system bus nodes (max. 64) are connected by a three-wire line.

The bus termination (at either first or last node) can be activated via DIP switches of the EM-SYS module. The system bus is equipped with three PDO (Process Data Object) channels that allow rapid exchanges of process data for each inverter. There are also two SDO (Service Data Object) channels for parameterisation purposes. Thanks to the three PDO channels, with one transmission and one reception channel, all inverter data can be transmitted. Among other advantages, this makes it possible to create master/slave and daisy chain configurations easily, while ensuring very high precision and speed.

Each transmission and reception channel includes 8 bytes that can be freely occupied by objects, thereby offering the maximum flexibility for a very broad range of applications. The selection of transmission objects and reception objects is made easy by the VPlus program, and no additional configuration tools are needed.

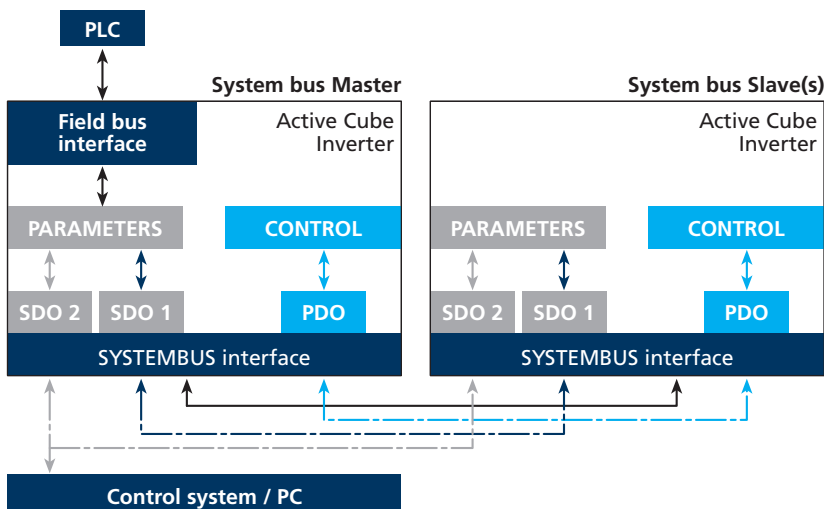

# EXPANSION MODULE EM-IO-XX



The EM-IO-xx expansion module extends the number of the standard inputs and outputs provided on the Active Cube inverter for connection of various applications. Analog inputs and outputs can be available also with bipolar signals and must therefore be configured with inverter parameters. The supplementary digital inputs provided on the expansion module are electrically equivalent to the standard inputs. The relay changer contact represents an alternative for the activation of high power to the relay output available as a standard feature. System bus is available on three control terminals and supports easy control of decentralised drive systems.

## EM-IO-01

Terminal board X410A	Terminal	Function
	X410A.1	20 V power supply output (180 mA)
	X410A.2	GND 20 V
	X410A.3	EM-S1IND multifunction digital input $V_{max} = 30\text{ V}$ (24 V/10 mA), PLC compatible
	X410A.4	EM-S2IND multifunction digital input $V_{max} = 30\text{ V}$ (24 V/10 mA), PLC compatible
	X410A.5	EM-S3IND multifunction digital input $V_{max} = 30\text{ V}$ (24 V/10 mA), PLC compatible
	X410A.6	EM-S1OUTD multifunction relay output, $U_{max} = 24\text{ V}$ , 1 A (ohmic)
	X410A.7	
Terminal board X410B	Terminal	Function
	X410B.1	EM-S2OUTD multifunction relay output, $U_{max} = 24\text{ V}$ , 1 A (ohmic)
	X410B.2	
	X410B.3	EM-S1INA +/- 10 V or +/- 20 mA analog input
	X410B.4	EM-S1OUTA +/- 10 V multifunction analog output
	X410B.5	CAN-Low System bus
	X410B.6	CAN-High System bus
	X410B.7	GND

## EM-IO-02

Terminal board X410A	Terminal	Function
	X410A.1	20 V power supply output (180 mA)
	X410A.2	GND 20 V
	X410A.3	EM-S1IND multifunction digital input $V_{max} = 30\text{ V}$ (24 V/10 mA), PLC compatible
	X410A.4	EM-S2IND multifunction digital input $V_{max} = 30\text{ V}$ (24 V/10 mA), PLC compatible
	X410A.5	EM-S3IND multifunction digital input $V_{max} = 30\text{ V}$ (24 V/10 mA), PLC compatible
	X410A.6	EM-S1OUTD multifunction relay output, $U_{max} = 24\text{ V}$ , 1 A (ohmic)
	X410A.7	
Terminal board X410B	Terminal	Function
	X410B.1	Input for motor PTC
	X410B.2	GND for motor PTC
	X410B.3	EM-S1INA +/- 10 V or +/- 20 mA analog input
	X410B.4	EM-S1OUTA +/- 10 V multifunction analog output
	X410B.5	CAN-Low System bus
	X410B.6	CAN-High System bus
	X410B.7	GND

## EM-IO-03

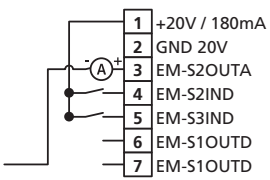
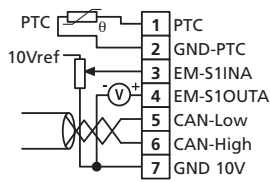
Terminal board X410A	Terminal	Function
 <p>1 +20V / 180mA 2 GND 20V 3 EM-S2OUTA 4 EM-S2IND 5 EM-S3IND 6 EM-S1OUTD 7 EM-S1OUTD</p>	X410A.1	20 V power supply output (180 mA)
	X410A.2	GND 20 V
	X410A.3	EM-S2OUTA analog output 0(4)-20 mA, $U_{max} = 10$ V
	X410A.4	EM-S2IND multifunction digital input $V_{max} = 30$ V (24 V/10 mA), PLC compatible
	X410A.5	EM-S3IND multifunction digital input $V_{max} = 30$ V (24 V/10mA), PLC compatible
	X410A.6	EM-S1OUTD multifunction relay output, $U_{max} = 24$ V, 1 A (ohmic)
	X410A.7	
Terminal board X410B	Terminal	Function
 <p>PTC 10Vref PTC 1 PTC 2 GND-PTC 3 EM-S1INA 4 EM-S1OUTA 5 CAN-Low 6 CAN-High 7 GND 10V</p>	X410B.1	Input for motor PTC
	X410B.2	GND for motor PTC
	X410B.3	EM-S1INA +/- 10 V or +/- 20 mA analog input
	X410B.4	EM-S1OUTA +/- 10 V analog output
	X410B.5	CAN-Low System bus
	X410B.6	CAN-High System bus
	X410B.7	GND

## EM-IO-04

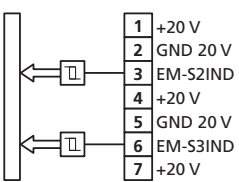
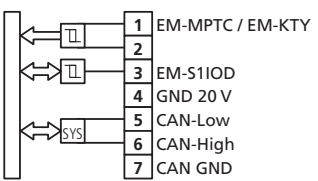
Terminal board X410A	Terminal	Function
 <p>1 +20 V 2 GND 20 V 3 EM-S2IND 4 +20 V 5 GND 20 V 6 EM-S3IND 7 +20 V</p>	X410A.1	Voltage output 20 V
	X410A.2	GND 20 V
	X410A.3	Digital input EM-S2IND
	X410A.4	Voltage output 20 V
	X410A.5	GND 20 V
	X410A.6	Digital input EM-S3IND
	X410A.7	Voltage output 20 V
Terminal board X410B	Terminal	Function
 <p>1 EM-MPTC / EM-KTY 2 3 EM-S1IOD 4 GND 20 V 5 CAN-Low 6 CAN-High 7 CAN GND</p>	X410B.1	Motor PTC thermistor connection EM-MPTC or connection motor temperature sensor
	X410B.2	EM-KTY
	X410B.3	Digital Port EM-S1IOD / Digital input or digital output
	X410B.4	GND 20 V
	X410B.5	CAN-Low System bus
	X410B.6	CAN-High System bus
	X410B.7	GND

# SPEED SENSOR MODULES EM-ENC-XX

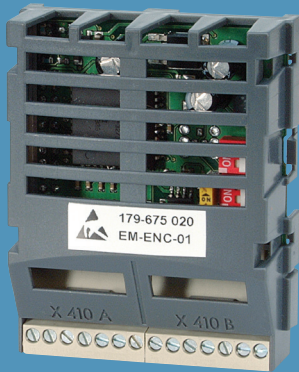

The EM-ENC-xx expansion module extends the number of speed sensor inputs of terminal board of the frequency inverter, and also increases the number of configurable pulse outputs with encoder repetition output. EM-ENC-xx is able to acquire both TTL and HTL incremental speed sensors according to standard EIA RS422 (line driver) with 5-volt logic. The EM-ENC-xx speed sensor module is equipped with connection terminals for signals A,  $\bar{A}$ , B and  $\bar{B}$  of the line driver speed sensor and terminals for repetition output of the same signals (speed sensor emulation). This makes it possible to create master-slave configurations between several separate units using output signals of one unit as input signals of the next.

## EM-ENC-01

Terminal board X410A	Terminal	Function
	X410A.1	Channel A speed sensor input
	X410A.2	Channel $\bar{A}$ speed sensor input
	X410A.3	Channel B speed sensor input
	X410A.4	Channel $\bar{B}$ speed sensor input
	X410A.5	+ 5 V (200 mA) power supply output
	X410A.6	5 V power supply GND
	X410A.7	Channel A repetition frequency output
Terminal board X410B	Terminal	Function
	X410B.1	Channel $\bar{A}$ repetition frequency output
	X410B.2	Channel B repetition frequency output
	X410B.3	Channel $\bar{B}$ repetition frequency output
	X410B.4	EM-S1INA +/- 10 V or +/- 20 mA analog input
	X410B.5	CAN-Low System bus
	X410B.6	CAN-High System bus
	X410B.7	GND

## EM-ENC-02

Terminal board X410A	Terminal	Function
	X410A.1	Channel A speed sensor input
	X410A.2	Channel $\bar{A}$ speed sensor input
	X410A.3	Channel B speed sensor input
	X410A.4	Channel $\bar{B}$ speed sensor input
	X410A.5	+ 5 V (200 mA) power supply output
	X410A.6	5V power supply GND
	X410A.7	EM-S1IND/OUTD digital input/output
Terminal board X410B	Terminal	Function
	X410B.1	Input for motor PTC
	X410B.2	GND for motor PTC
	X410B.3	EM-S1OUTA 0 ... 20 mA analog output
	X410B.4	EM-S1INA +/- 10 V and +/- 20 mA analog input
	X410B.5	CAN-Low System bus
	X410B.6	CAN-High System bus
	X410B.7	GND

## EM-ENC-03

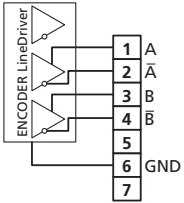
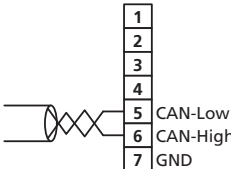
Terminal board X410A	Terminal	Function
	X410A.1	Channel A speed sensor input
	X410A.2	Channel $\bar{A}$ speed sensor input
	X410A.3	Channel B speed sensor input
	X410A.4	Channel $\bar{B}$ speed sensor input
	X410A.5	-
	X410A.6	GND
	X410A.7	-
Terminal board X410B	Terminal	Function
	X410B.1	-
	X410B.2	-
	X410B.3	-
	X410B.4	-
	X410B.5	CAN-Low System bus
	X410B.6	CAN-High System bus
	X410B.7	GND

## EM-ENC-04

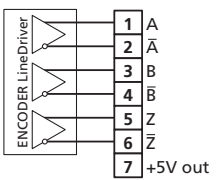
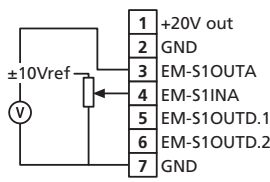
Terminal board X410A	Terminal	Function
	X410A.1	Channel A speed sensor input
	X410A.2	Channel $\bar{A}$ speed sensor input
	X410A.3	Channel B speed sensor input
	X410A.4	Channel $\bar{B}$ speed sensor input
	X410A.5	Channel Z speed sensor input
	X410A.6	Channel $\bar{Z}$ speed sensor input
	X410A.7	+ 5 V power supply output (200mA)
Terminal board X410B	Terminal	Function
	X410B.1	+ 20 V power supply output (180 mA)
	X410B.2	Power supply GND
	X410B.3	$\pm 10$ V analog output
	X410B.4	EM-S1INA $\pm 10$ V or $\pm 20$ mA analog input
	X410B.5	EM-S1OUTD multifunction relay output, $U_{max} = 24$ V, 1 A (ohmic)
	X410B.6	
	X410B.7	GND

## EM-ENC-05

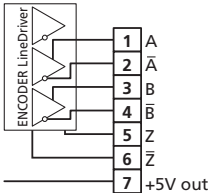
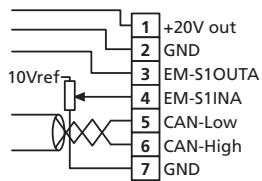
Terminal board X410A	Terminal	Function
	X410A.1	Channel A speed sensor input
	X410A.2	Channel $\bar{A}$ speed sensor input
	X410A.3	Channel B speed sensor input
	X410A.4	Channel $\bar{B}$ speed sensor input
	X410A.5	Channel Z speed sensor input
	X410A.6	Channel $\bar{Z}$ speed sensor input
	X410A.7	+ 5 V power supply output (200mA)
Terminal board X410B	Terminal	Function
	X410B.1	+ 20 V power supply output (180 mA)
	X410B.2	Power supply GND
	X410B.3	$\pm 10$ V analog output
	X410B.4	EM-S1INA $\pm 10$ V and $\pm 20$ mA analog input
	X410B.5	CAN-Low System bus
	X410B.6	CAN-High System bus
	X410B.7	GND

# RESOLVER MODULE EM-RES-01/EM-RES-02



- Resolver evaluation
- Frequency repetition output (Two channels without Zero-Pulse channel)
- Analog input
- System bus

## EM-RES-01

Terminal board X410A		Terminal	Function
	1	X410A.1	(+) $\sim 4 V_{rms}$ resolver power supply
	2	X410A.2	(-) ( $I_{max} = 60mA$ )
	3	X410A.3	Resolver $\sin\theta$ signal input
	4	X410A.4	
	5	X410A.5	Resolver $\cos\theta$ signal input
	6	X410A.6	
	7	X410A.7	Channel A Repetition frequency output

Terminal board X410B		Terminal	Function
	1	X410B.1	Channel $\bar{A}$ Repetition frequency output
	2	X410B.2	Channel B Repetition frequency output
	3	X410B.3	Channel $\bar{B}$ Repetition frequency output
	4	X410B.4	$\pm 10 V$ or $\pm 20 mA$ analog input
	5	X410B.5	CAN-Low System bus
	6	X410B.6	CAN-High System bus
	7	X410B.7	GND

## EM-RES-02

Terminal board X410A		Terminal	Function
	1	X410A.1	(+) $\sim 4 V_{rms}$ resolver power supply
	2	X410A.2	(-) ( $I_{max} = 60mA$ )
	3	X410A.3	Resolver $\sin\theta$ signal input
	4	X410A.4	
	5	X410A.5	Resolver $\cos\theta$ signal input
	6	X410A.6	
	7	X410A.7	Channel A Repetition frequency output

Terminal board X410B		Terminal	Function
	1	X410B.1	Channel $\bar{A}$ Repetition frequency output
	2	X410B.2	Channel B Repetition frequency output
	3	X410B.3	Channel $\bar{B}$ Repetition frequency output
	4	X410B.4	$\pm 10 V$ or $\pm 20 mA$ analog input
	5	X410B.5	Channel Z Repetition frequency output
	6	X410B.6	Channel $\bar{Z}$ Repetition frequency output
	7	X410B.7	GND

# RESOLVER MODULE EM-RES-03

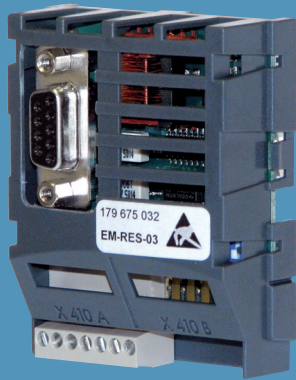

EM-RES-03 resolver module extends the standard functions of Active Cube frequency inverter providing a supplementary input for resolver.

It is designed specifically for BMD synchronous servomotors resolver feedback acquisition. EM-RES-03 is equipped with a DSUB-9 connector, that allows fast and easy connection to Bonfiglioli synchronous servomotors, when using BMD power and control cables.

## EM-RES-03

Terminal board X410A		Terminal	Function
	1	+24 V / 180 mA	X410A.1 DC-24 V output (max. 180 mA)
	2	GND 24 V	X410A.2 Ground 24 V
	3	EM-S1OUTD	X410A.3 Digital output EM-S1OUTD
	4	EM-S2OUTD	X410A.4 Digital output EM-S2OUTD
	5	N.C.	X410A.5 Not connected
	6	EM-S1INA	X410A.6 EM-S1INA +/- 10 V analog input
	7	GND 10 V	X410A.7 GND

Terminal board X410B		Terminal	Function
	1	N.C.	X410B.1 Not connected
	2	EM-S1IND	X410B.2 Digital input EM-S1IND
	3	EM-S2IND	X410B.3 Digital input EM-S2IND
	4	EM-S3IND	X410B.4 Digital input EM-S3IND
	5	CAN-Low	X410B.5 CAN-Low System bus
	6	CAN-High	X410B.6 CAN-High System bus
	7	GND	X410B.7 GND

Resolver- and PTC input (DSUB-9)	Pin	Designation	Function
	Socket	Shielding	Connected with PE
	1	PE	Protective earth conductor
	2	PTC+	PTC thermistor connection
	3	COS+	Cosinus track
	4	SIN+	Sinus track
	5	+UE	Excitation voltage ( $7 V_{rms}$ )
	6	PTC-	PTC thermistor connection
	7	COS-	Cosinus track
	8	SIN-	Sinus track
9	-UE	Excitation voltage ( $7 V_{rms}$ )	

# ABSOLUTE ENCODER MODULE EM-ABS-01



The expansion module EM-ABS-01 extends the ability of Active Cube inverter to acquire an absolute encoder feedback through a DSUB-15 connector.

The following encoder standards can be connected to the drive via EM-ABS-01:

- SinCos (optionally with commutation tracks for synchronous motors)
- EnDat 2.2 with SinCos track
- Hiperface
- SSI (optionally with TTL [RS-422] or SinCos track)

Additional signal and functions are available when using EM-ABS-01:

- System bus CAN (Can interface ISO-DIS 11898, CAN High Speed, max 1 Mbaud)
- Analog input DC -10...+10V or DC 0...+10V
- 3 digital inputs
- 2 digital outputs

## EM-ABS-01

Terminal board X410A		Terminal	Function
	1	X410A.1	Voltage input DC 24 V
	2	X410A.2	GND DC 24 V
	3	X410A.3	Digital output EM-S1OUTD
	4	X410A.4	Digital output EM-S2OUTD
	5	X410A.5	Voltage output DC 5 ... 12 V
	6	X410A.6	EM-S1INA +/- 10 V analog input
	7	X410A.7	GND

Terminal board X410B		Terminal	Function
	1	X410B.1	GND
	2	X410B.2	Digital input EM-S1IND
	3	X410B.3	Digital input EM-S2IND
	4	X410B.4	Digital input EM-S3IND
	5	X410B.5	CAN-Low System bus
	6	X410B.6	CAN-High System bus
	7	X410B.7	GND

Contact	Function			
Housing	Sin/Cos	Hiperface	EnDat 2.2	SSI
1	PE	PE	PE	PE
2	D-		Clock-	Clock-
3	D+		Clock+	Clock+
4	Cos-	Cos-	B- / Cos-	(optionally B- / Cos-)
5	Cos+	Cos+	B+ / Cos+	(optionally B- / Cos-)
6	TM <sub>PTC</sub> -	TM <sub>PTC</sub> -	TM <sub>PTC</sub> -	TM <sub>PTC</sub> -
7	V <sub>ENC</sub>	V <sub>ENC</sub>	V <sub>ENC</sub>	V <sub>ENC</sub>
8	R-			
9	C-	Data-	Data-	Data-
10	Sin-	Sin-	A- / Sin-	(optionally A- / Sin-)
11	TM <sub>PTC</sub> +	TM <sub>PTC</sub> +	TM <sub>PTC</sub> +	TM <sub>PTC</sub> +
12	V <sub>ENC</sub> Sensor		V <sub>ENC</sub> Sensor	V <sub>ENC</sub> Sensor
13	R+			
14	C+	Data+	Data+	Data+
15	Sin+	A+ / Sin+	A+ / Sin+	(optionally A+ / Sin+)
	GND	GND	GND	GND

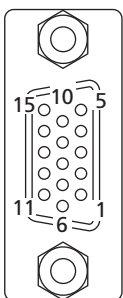

# SAFE TORQUE OFF (STO)

The Functional Safety Function "Safe Torque Off" (STO) with the safety integrity level SIL 3 (EN 61508 and DIN IEC 61800-5-2) and Performance level PL e (EN 13849-1) is implemented into standard Active Cube inverter range.

When triggering the STO function the frequency inverter switches off the rotating field of the motor.

Deactivation of the inverter supply is carried out via two switch off paths in no-signal current mode, thus performing redundant switch off control.

Continuous monitoring tests are done by the inverter to detect possible control failures.

"Safe Torque Off" function greatly improves safety level of your automation system without the need of additional components.

Without STO

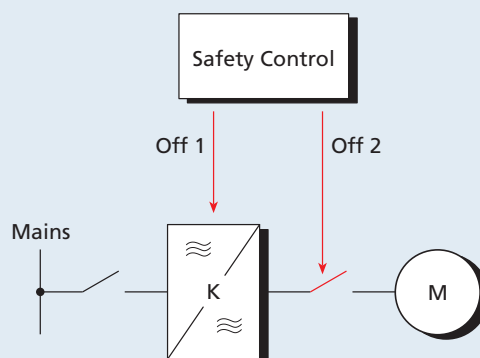

With STO

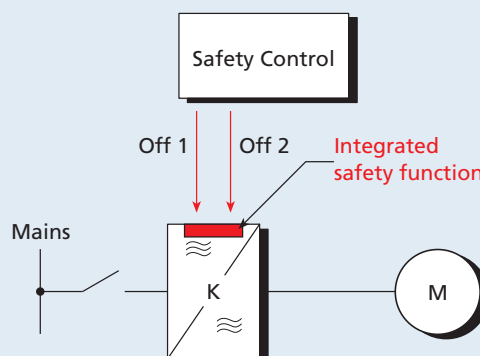

# MOUNTING OF STANDARD DEVICES

A wide range of mechanical accessories is available for Active Cube Series frequency inverters, to make installation as easy as possible in all sorts of applications.

In standard mountings the unit can be installed directly on the mounting plate or through-the-wall with optional mounting equipment. A vibration-proof mounting variant and a standard DIN bar mounting variant are also available.

The range of mounting variants also includes an optional support with shielded brackets, so that the right solution for all possible needs can always be found.

Installations are almost identical for all sizes, so the examples shown below can be taken as representative solutions and ideal for all installers seeking a mechanically simple, compact installation solution.

## Types of mounting kits

The drive is supplied complete for fixing to an electrical cabinet mounting panel. 3 optional installation kits are additionally available.

### **MSTD (Standard Mounting Kit)**

The Standard Mounting Kit is always included for devices for mounting version "A".

### **MPSV**

Thru-type assembly for higher protection classes or enhanced cooling characteristics.

### **MNVIB**

Anti-vibration mounting for installations on machines that generate significant vibrational stress.

### **MDIN**

DIN rail assembly for fast and modular installation / coupling.

# MOUNTING OF SIZE 1

Active Cube	Mounting	Description
	Standard	Standard mounting
210-xx 1 ... 410-xx 1 ...	MPSV1	Thru-type mounting
	MNVIB1	Antivibration mounting
	MDIN1	DIN rail mounting

## MSTD1-2 (STANDARD MOUNTING)

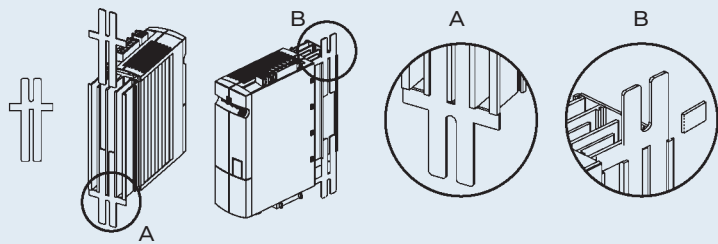

## MPSV1

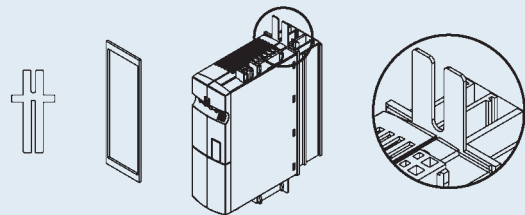

## MNVIB1

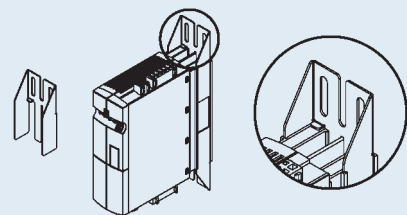

## MDIN1

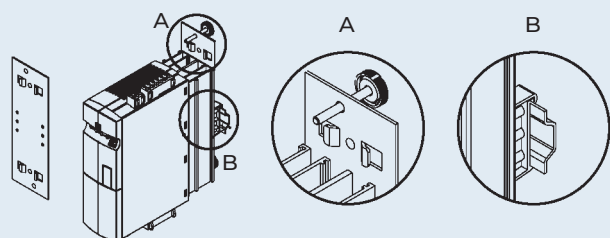

# MOUNTING OF SIZE 2

Active Cube	Mounting	Description
210-xx 2 ... 410-xx 2 ...	Standard	Standard mounting
	MPSV2	Thru-type mounting
	MNVIB2	Antivibration mounting
	MDIN2	DIN rail mounting

**MSTD1-2**  
(STANDARD MOUNTING)

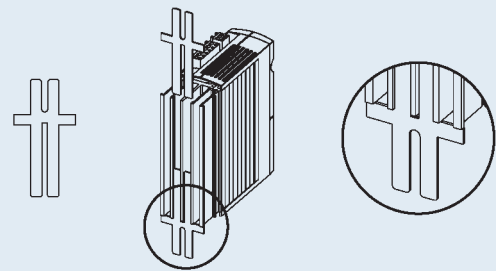

**MPSV2**

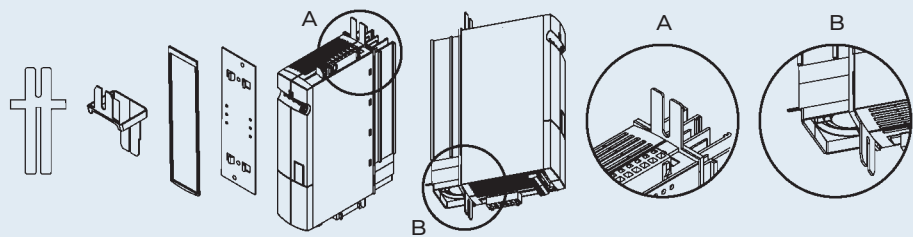

**MNVIB2**

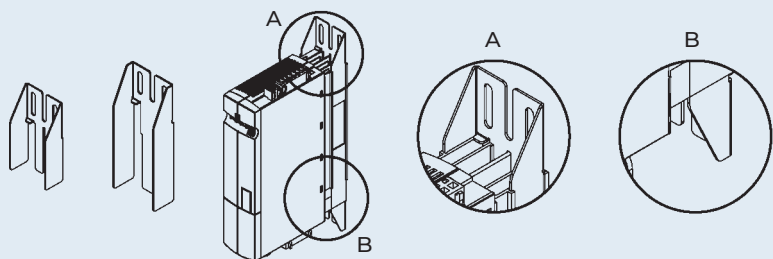

**MDIN2**

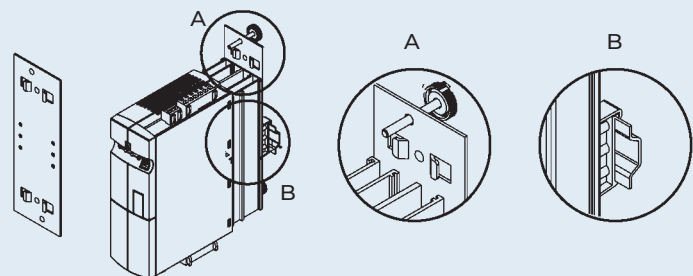

# MOUNTING OF SIZE 3

Active Cube	Mounting	Description
210-xx 3 ... 410-xx 3 ...	Standard	Standard mounting
	MPSV3	Thru-type mounting
	MNVIB3	Antivibration mounting

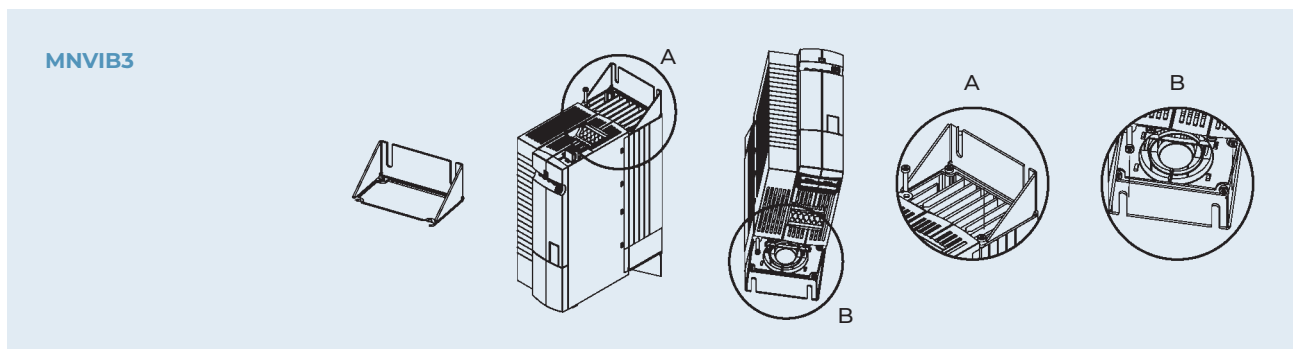
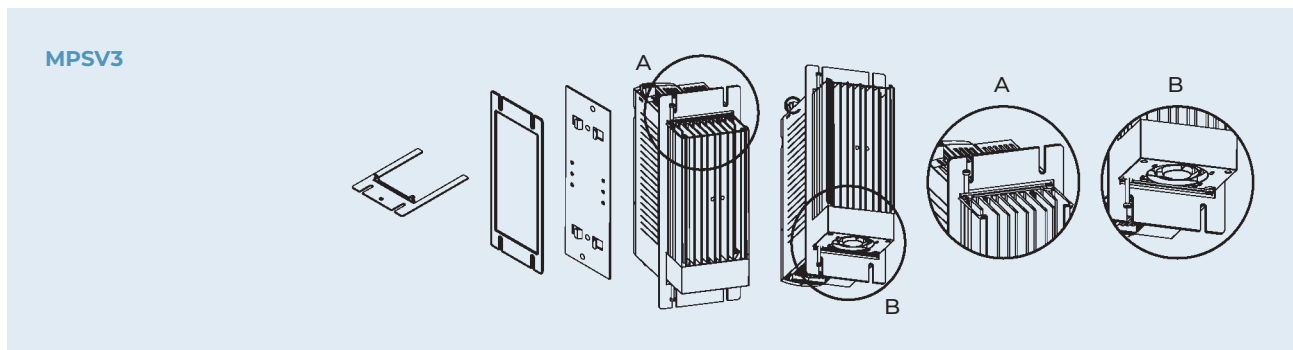
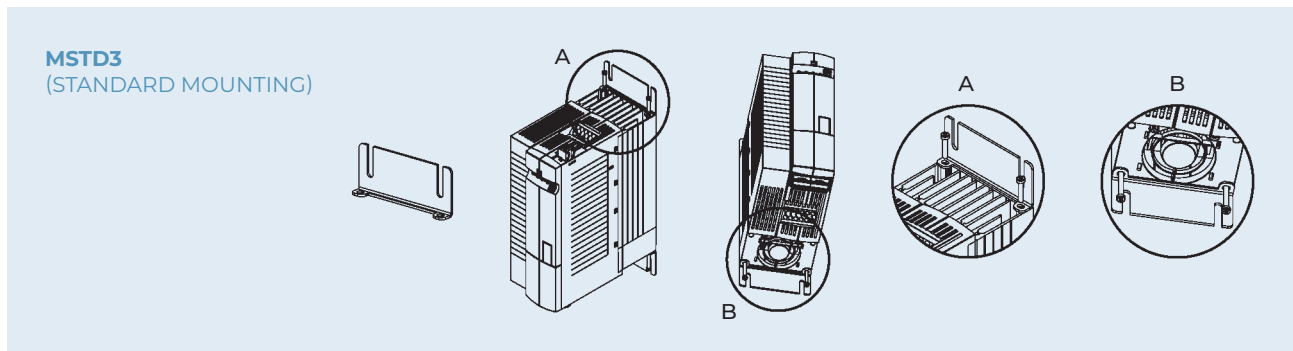

# MOUNTING OF SIZE 4

Active Cube	Mounting	Description
210-xx 4 ... 410-xx 4 ...	Standard	Standard mounting
	MPSV4	Thru-type mounting
	MNVIB4	Antivibration mounting

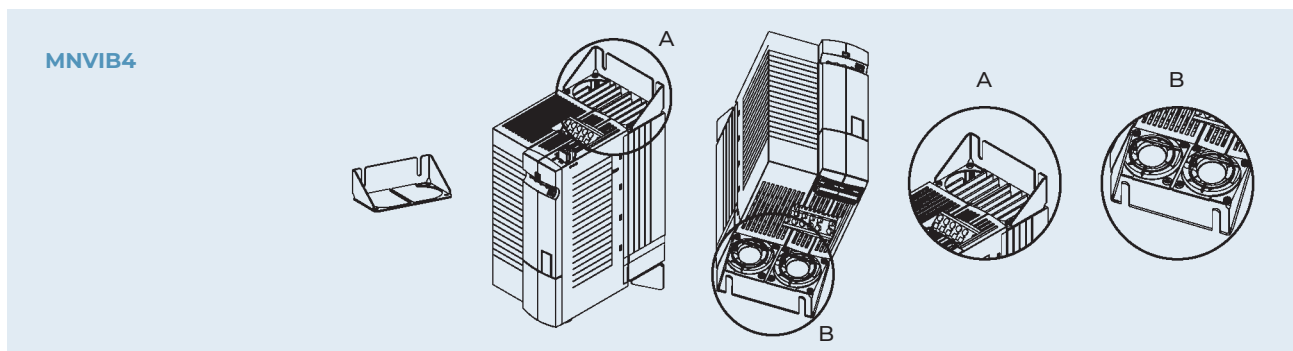
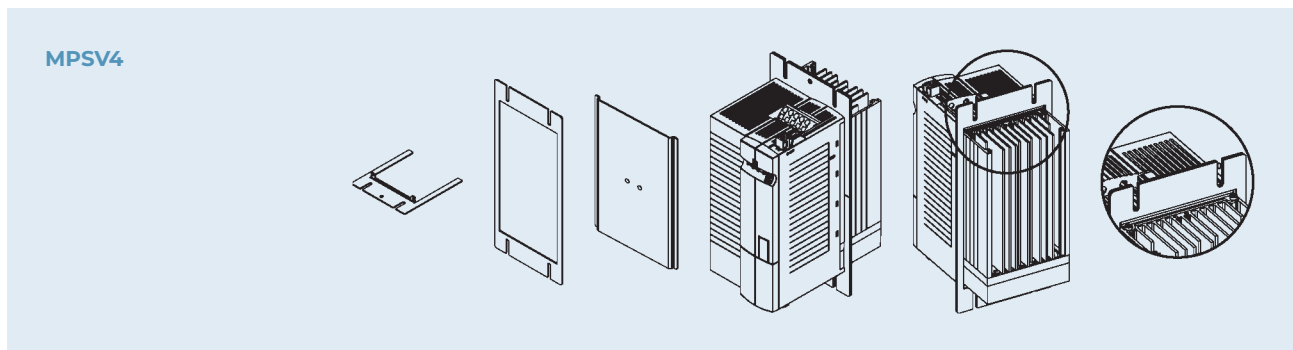
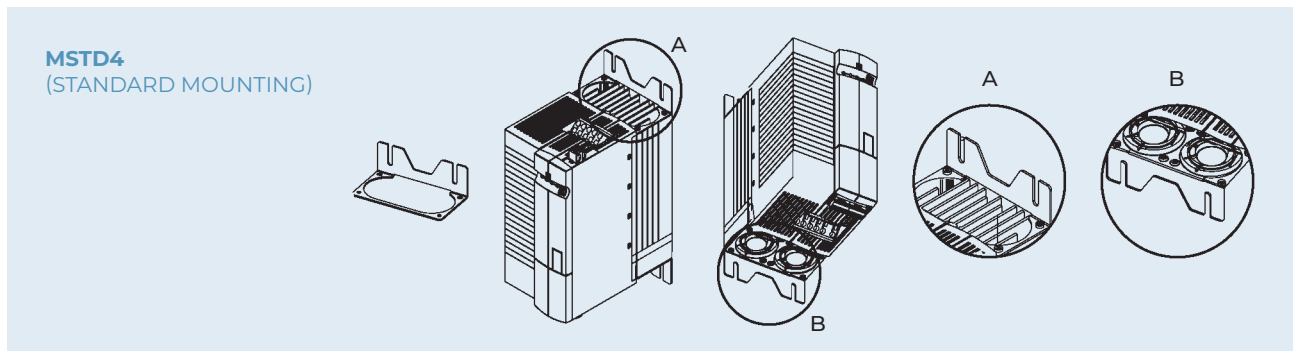

# MOUNTING OF SIZE 5

Active Cube	Mounting	Description
410-xx 5 ...	Standard	Standard mounting
	MPSV5	Thru-type mounting
	MNVIB5	Antivibration mounting

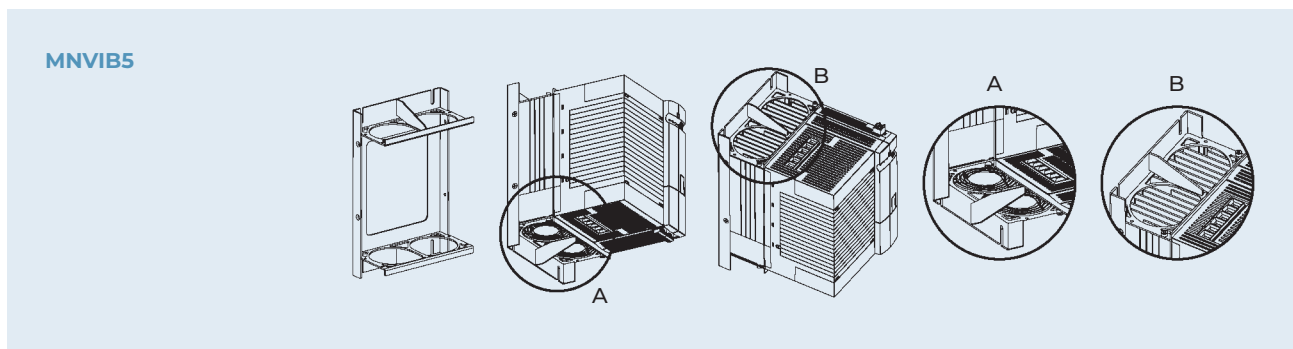
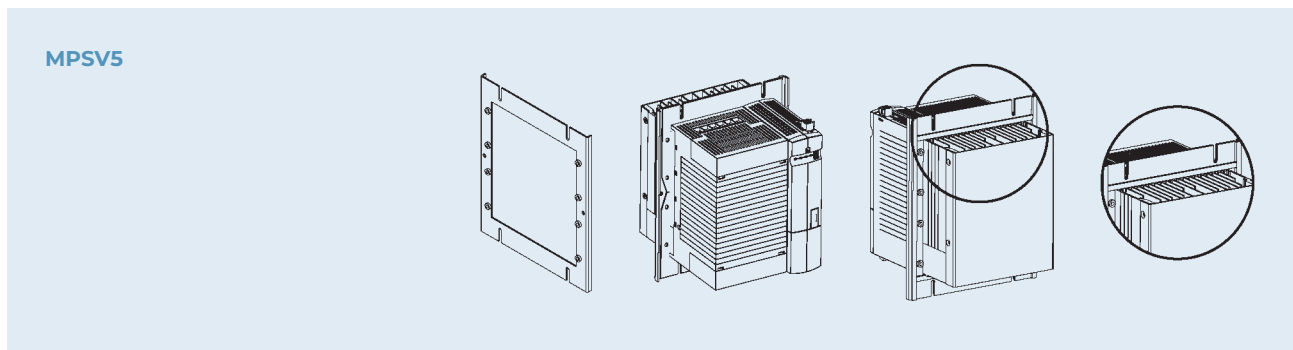
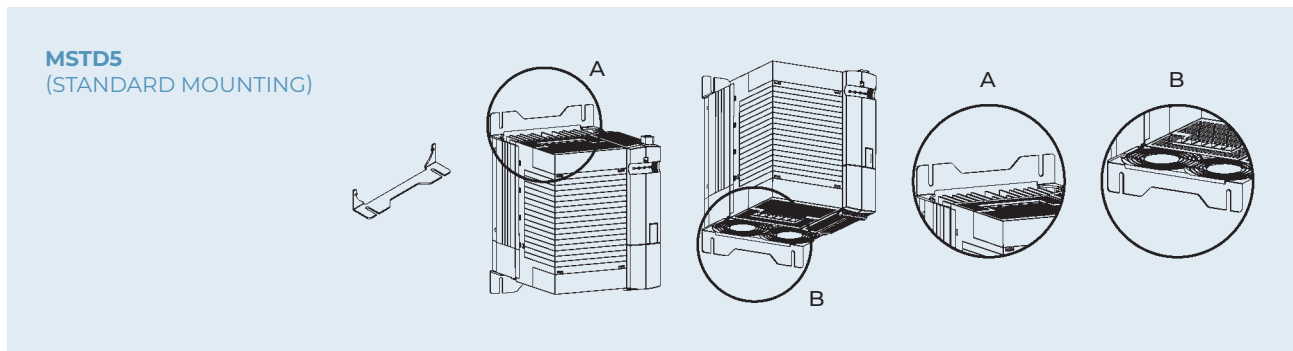

# MOUNTING OF SIZE 6

Active Cube	Mounting	Description
410-xx 6 ...	Standard	Standard mounting
	MPSV6	Thru-type mounting
	MNVIB6	Antivibration mounting

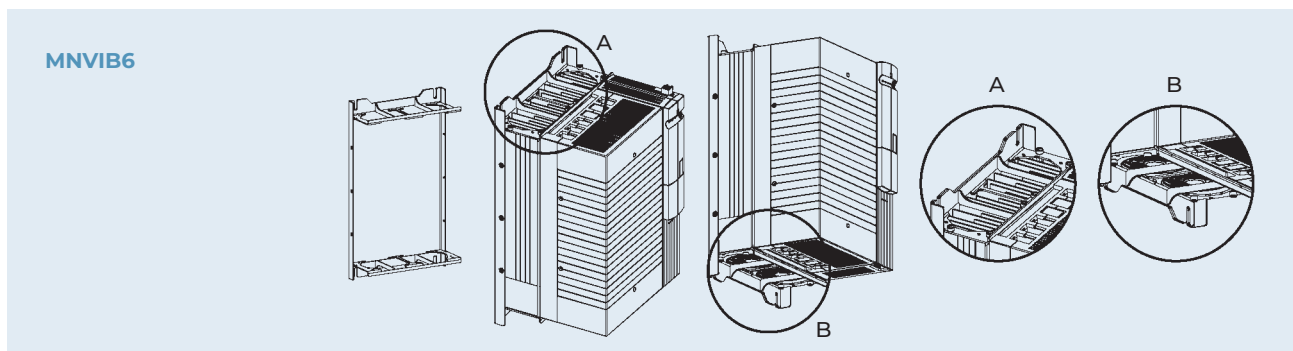
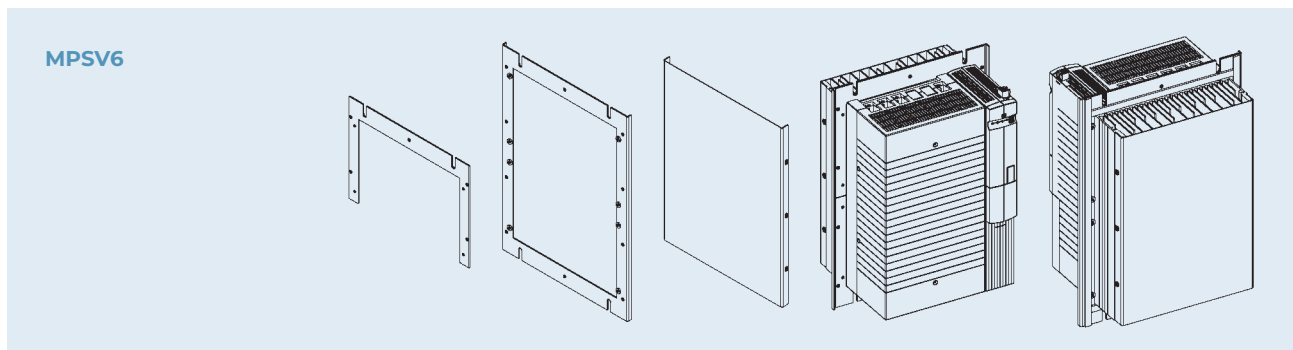
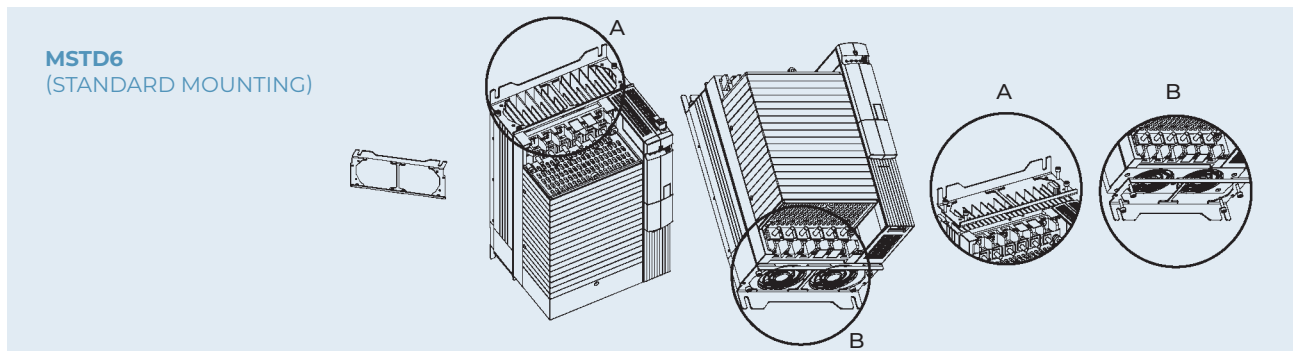

# MOUNTING OF SIZE 7

Active Cube	Mounting	Description
410-xx 7 ...	Standard	Standard mounting
	MPSV7	Thru-type mounting

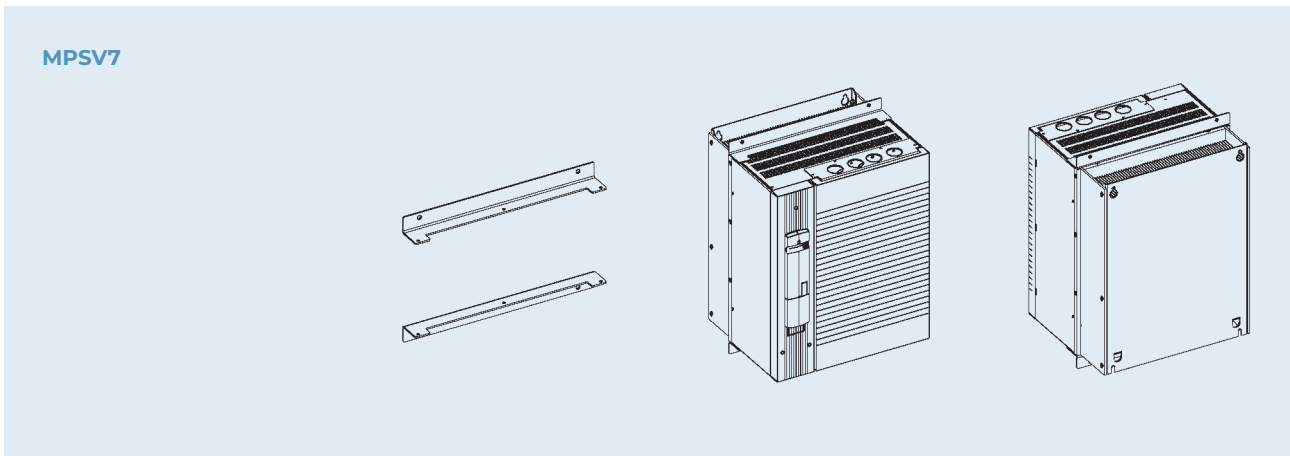
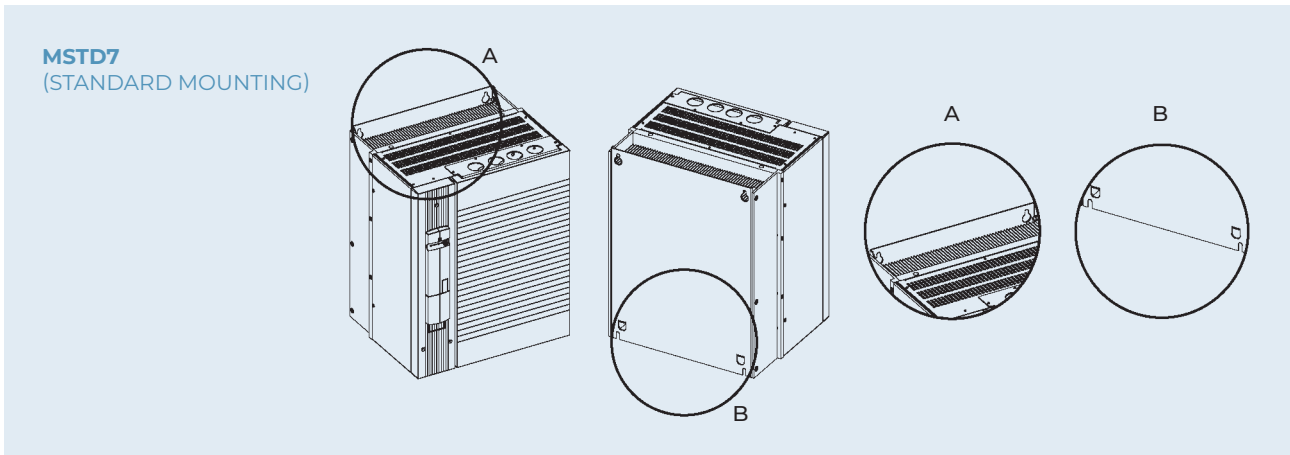

# MOUNTING OF SIZE 8

Active Cube	Mounting	Description
410-xx 8 ... 510-xx 8 ... 610-xx 8 ...	Standard	Standard mounting

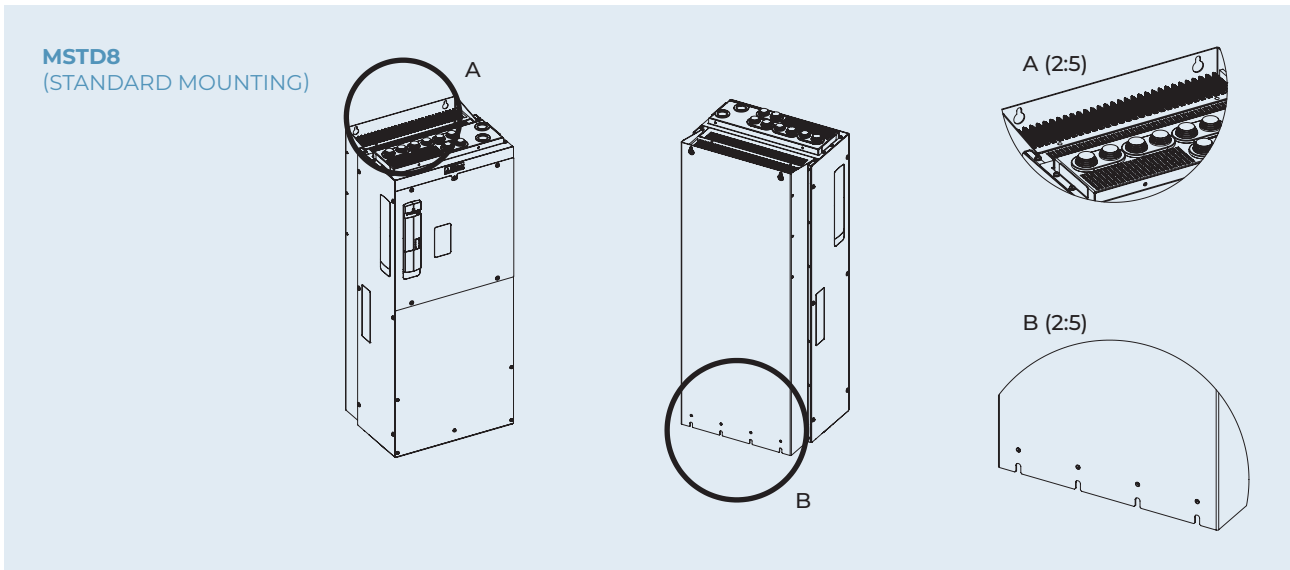

# INPUT FILTER

## Why an input filter?

An Input Filter is a filtration device to be installed up-line from the frequency inverter and down-line from the power feeding contactor.

The AC/DC rectifier at the inverter input generates harmonic disturbance on the absorbed current and emits disturbance generated by switching components towards the mains.

This harmonic current causes voltage distortions on the mains resulting in electromagnetic interference phenomena.

This harmonic distortion is reduced by means of line chokes, while disturbance is countered with EMC filters (attenuation of EMC voltages) such as those described below.

*Note: the use of input filters reduces the inverter input voltage. If required, these filters should be installed up-line from the inverter in the following order:*

1. Mains supply
2. Line choke
3. EMC filter
4. Inverter

## EMC Standards

The standard EN 61800-3 defines the EMC levels for drive systems and for machinery. Depending on the EMC environment different solutions on the inverter side are available to achieve the required EMC level.

## Line choke

- The use of Line chokes depends on the system engineer's need to reduce harmonic distortion in the short circuit point and the need to reinforce the action of the EMC filter. A line choke is highly recommended when the PCC (Point of common coupling) of the mains power supply for the drive has an RSC higher than 100.
- A line choke is recommended for the ACU210 and ACU410 frequency inverter series in the presence of high continuous input current required by the application, in order to increase the lifetime of the electrolytic capacitors.
- A line choke is always required in single and two-phase operation of the ACU210 frequency inverters and in sizes 7 and 8. For other devices please check the markings in the technical data tables.

## EMC filter

- An EMC filter can be used in order to achieve Class C3, C2 or C1 interference suppression.
- The EMC filter is available in a low leakage current version for special applications.
- The EMC - filter is part of the standard outfit in mechanical sizes 1 & 2 and it is supplied as an internal option in mechanical size 3 and external option in size 3 and bigger.

## Active Cube inverter - Line choke / EMC filter combination

EN 55011	Compliance with CLASS A (GROUP 2)		Compliance with CLASS A (GROUP 1)		Compliance with CLASS B	
EN61800-3	Compliance with CATEGORY C3		Compliance with CATEGORY C2		Compliance with CATEGORY C1	
Motor cable length	< 10 m	< max*	< 10 m	< max*	< 10 m	< max*
ACU size 1 (standard internal filter)	Standard	external choke	Standard	external filter	external choke	external filter
ACU size 2 (standard internal filter)	Standard	external choke	Standard	external filter	external choke	external filter
ACU size ACU 3	internal filter or external choke	internal filter or external choke	internal filter + external choke	internal filter + external choke	internal filter + external choke	external filter
ACU size 4	external choke	external choke	external filter	external filter	external filter	external filter + external choke
ACU size 5	external choke	external choke	external filter	external filter	external filter	external filter + external choke
ACU size 6	external choke	external choke	external filter	external filter	external filter	external filter
ACU size 7	external choke	external filter	external filter	external filter	—	—
ACU size 8	external choke	external choke	external filter + external choke	external filter + external choke	—	—

\* See the operation manual



# LINE CHOKE



The simplest way of reducing high harmonic components and hence reactive power is connecting a choke in series on the mains side of the inverter. Depending on the system, reactive power consumption can be reduced by approximately 20% of the figure without line choke.

The line choke increases inductance towards the mains. Mains feed line choke can be regarded as sufficient if short-circuit power is from 20 to 40 times higher than the inverter nominal output.

The inverter is suitable for connection to public or industrial mains supplies in compliance with technical data. If the supply mains transformer output is  $\leq 500$  kVA, the optional mains choke is needed only if specified in the inverter technical data. The other inverters are suitable for the connection to the mains without a mains choke with relative impedance  $\geq 1\%$ . If it is desired to connect more than one inverter, use the sum of the nominal outputs as a basis.

Since experience has shown that the nominal short circuit power on the inverter connection point is often unknown, BONFIGLIOLI recommends the use of mains chokes with 4% relative short circuit voltage.

The relative short circuit voltage equivalent to a 4% voltage drop represents the percentage of the nominal voltage at which a current equal to rated current flows in the case of a short circuit.

**The line choke must be installed between the mains connection point and the EMC filter. Both the line choke and inverter should be installed on a common metal baseplate and each should be connected to the metal mounting plate and earthed by means of a large contact area copper braid.**

## Technical data

### Mains voltage

- 230V +/- 10%
- 400V +/- 10%

### Frequencies

- 50/60 Hz
- uk (a IN / 50 Hz) 4%

### Insulating material class

- T40/F

### Ambient temperature

- 40°C

### Protection degree (EN 60529)

- IP00

### Connection type

- Contact-protected terminals

### LCVS006 ... LCVS018

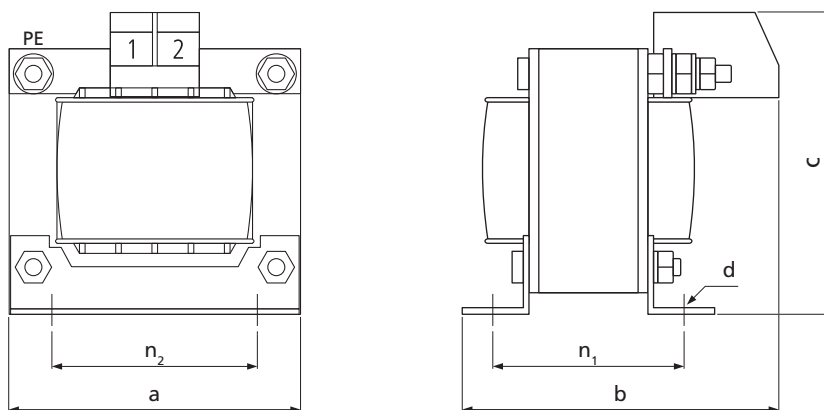

## Technical data

Bonfiglioli frequency inverter - Line choke combination, 1x230V~

Inverter type	Line choke	Nominal current	Power dissipation
		[A]	[W]
<b>ACU 210-01</b>	LCVS006	6	8.0
<b>ACU 210-03</b>			
<b>ACU 210-05</b>			
<b>ACU 210-07</b>	LCVS008	8	8.0
<b>ACU 210-09</b>	LCVS010	10	10.0
<b>ACU 210-11</b>	LCVS015	15	12.0
<b>ACU 210-13</b>	LCVS018	18	15.0

## Technical assembly data

Line choke	Dimensions			Assembly			Weight	Connection terminal		
	a	b	c	n <sub>2</sub>	n <sub>1</sub>	d	kg	mm	Nm	PE
LCVS006	60	62	75	44	38	3.6	0.5	0.75-2.5	1.0-1.2	2.5 mm <sup>2</sup>
LCVS008	60	67	75	44	43	3.6	0.6	0.75-2.5	1.0-1.2	2.5 mm <sup>2</sup>
LCVS010	66	80	70	50	51	4.8	0.8	0.75-2.5	1.0-1.2	M4
LCVS015	78	78	80	56	49	4.8	1.1	0.75-4.0	1.5-1.8	M4
LCVS018	85	85	95	64	50	4.8	1.8	0.75-4.0	1.5-1.8	M4

# LINE CHOKE

LCVT004 ... LCVT025

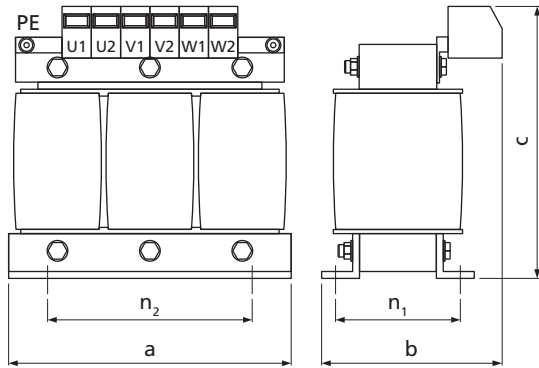

LCVT034 ... LCVT250

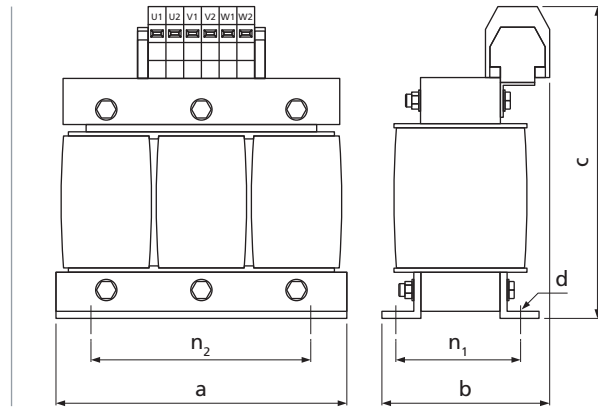

LCVT280AL-xxx ... LCVT690AL-xxx

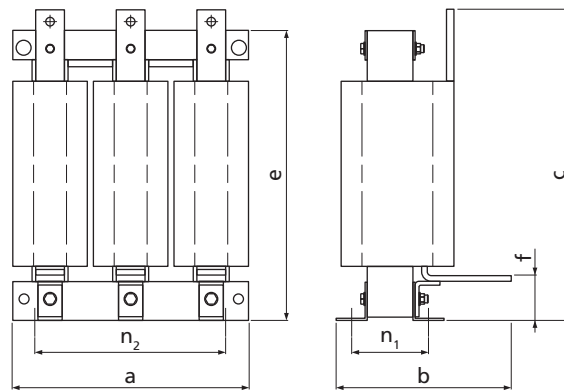

## Technical data

Bonfiglioli frequency inverter – Line choke combination, 3x230V~

Inverter type	Line choke	Nominal current	Choke	Power dissipation
		[A]	[mH]	[W]
ACU 210-01	LCVT004	4	7.32	20
ACU 210-03				
ACU 210-05				
ACU 210-07				
ACU 210-09	LCVT006	6	4.88	25
ACU 210-11	LCVT008	8	3.66	30
ACU 210-13	LCVT010	10	2.93	30
ACU 210-15	LCVT015	15	1.95	45
ACU 210-18	LCVT018	18	1.63	70
ACU 210-19	LCVT025	25	1.17	70
ACU 210-21	LCVT034	34	0.86	85
ACU 210-22				

## Technical data

Bonfiglioli frequency inverter – Line choke combination, 3x400V~, 3x525V~, 3x690V

Inverter type	Line choke	Nominal current [A]	Choke [mH]	Power dissipation [W]
ACU 410-01	LCVT004	4	7.32	20
ACU 410-03				
ACU 410-05				
ACU 410-07				
ACU 410-09				
ACU 410-11				
ACU 410-12				
ACU 410-13	LCVT006	6	4.88	25
ACU 410-15	LCVT008	8	3.66	30
ACU 410-18	LCVT010	10	2.93	30
ACU 410-19	LCVT015	15	1.95	45
ACU 410-21	LCVT018	18	1.63	70
ACU 410-22	LCVT025	25	1.17	70
ACU 410-23	LCVT025	25	0.86	85
ACU 410-25	LCVT034	34	0.86	85
ACU 410-27	LCVT050	50	0.59	100
ACU 410-29	LCVT060	60	0.49	100
ACU 410-31				
ACU 410-33	LCVT075	75	0.37	110
ACU 410-35	LCVT090	90	0.33	120
ACU 410-37	LCVT115	115	0.25	140
ACU 410-39	LCVT135	135	0.22	180
ACU 410-43	LCVT160	160	0.18	180
ACU 410-45	LCVT180	180	0.16	185
ACU 410-47	LCVT210	210	0.14	200
ACU 410-49	LCVT250	250	0.12	210
ACU 410-51	LCVT280AL-525	280	0.105	460
ACU 410-53	LCVT350AL-525	350	0.084	500
ACU 410-55	LCVT440AL-525	440	0.068	630
ACU 410-57	LCVT550AL-525	550	0.052	680
ACU 410-59	LCVT690AL-400	620	0.046	640
ACU 410-61	LCVT690AL-400	690	0.046	790
ACU 510-51	LCVT215AL-525	215	0.13	370
ACU 510-53	LCVT280AL-525	270	0.105	430
ACU 510-55	LCVT350AL-525	335	0.084	460
ACU 510-57	LCVT440AL-525	420	0.068	575
ACU 510-59	LCVT470AL-525	470	0.06	610
ACU 510-61	LCVT550AL-525	525	0.052	620
ACU 610-51	LCVT160AL-690	160	0.33	350
ACU 610-53	LCVT200AL-690	200	0.27	420
ACU 610-55	LCVT250AL-690	250	0.21	480
ACU 610-57	LCVT320AL-690	320	0.18	570
ACU 610-59	LCVT360AL-690	360	0.15	630
ACU 610-61	LCVT410AL-690	410	0.13	660

# LINE CHOKE

## Technical assembly data

Line choke	Dimensions			Assembly			Weight	Connection terminal		
	a	b	c	n <sub>2</sub>	n <sub>1</sub>	d	kg	mm	Nm	PE
LCVT004	80	65	95	55	37	4	0.8	0.75-2.5	1.0-1.2	4 mm <sup>2</sup>
LCVT006	100	65	115	60	39	4	1.0	0.75-2.5	1.0-1.2	4 mm <sup>2</sup>
LCVT008	100	75	115	60	48	4	1.5	0.75-2.5	1.0-1.2	4 mm <sup>2</sup>
LCVT010	100	75	115	60	48	4	1.5	0.75-2.5	1.0-1.2	4 mm <sup>2</sup>
LCVT015	125	85	135	100	55	5	3.0	0.75-4.0	1.5-1.8	4 mm <sup>2</sup>
LCVT018	155	90	135	130	57	8	4.0	0.75-4.0	1.5-1.8	4 mm <sup>2</sup>
LCVT025	155	100	160	130	57	8	4.0	0.75-10	4.0-4.5	4 mm <sup>2</sup>
LCVT034	155	100	190	130	57	8	4.5	2.5-16	2.0-4.0	M5
LCVT050	155	115	190	130	72	8	4.5	2.5-16	2.0-4.0	M5
LCVT060	190	110	220	170	58	8	9.0	2.5-35	2.5-5.0	M5
LCVT075	190	120	250	170	68	8	12	25-50	3.0-6.0	M6
LCVT090	190	130	250	170	78	8	12	25-50	3.0-6.0	M6
LCVT115	210	140	270	180	82	8	14	25-50	3.0-6.0	M6
LCVT135	240	160	300	190	100	11	20	16-70	6.0-7.0	M8
LCVT160	240	160	310	190	100	11	20	50-95	6.0-12.0	M8
LCVT180	240	175	320	190	106	11	22	50-95	6.0-12.0	M8
LCVT210	240	200	335	190	121	11	26	95-150	10.0-20.0	M8
LCVT250	240	210	350	190	126	11	28	95-150	10.0-20.0	M8

Line choke	Dimensions					Assembly		Weight	Connection terminal			
	a	b	c	e	f	n <sub>2</sub>	n <sub>1</sub>	[kg]	Phases	[Nm]	PE	[Nm]
<b>ACU410</b>												
LCVT280AL-525	360	213	335	362	65	325	112	47	M10	25-30	M8	20-25
LCVT350AL-525	360	225	335	361	65	325	124	55	M10	25-30	M10	40-50
LCVT440AL-525	394	266	450	434	74	325	127	70	2xM12	25-30	M10	40-50
LCVT550AL-525	394	291	470	435	75	325	142	83	2xM12	25-30	M10	40-50
LCVT690AL-400	394	291	520	485	75	325	142	85	2xM12	25-30	M12	75-85
<b>ACU510</b>												
LCVT215AL-525	360	195	285	311	65	325	99	35	M10	25-30	M8	20-25
LCVT280AL-525	360	213	335	362	65	325	112	47	M10	25-30	M8	20-25
LCVT350AL-525	360	225	335	361	65	325	124	55	M10	25-30	M10	40-50
LCVT440AL-525	394	266	450	434	74	325	127	70	2xM12	25-30	M10	40-50
LCVT470AL-525	394	325	449	433	74	325	127	72	2xM12	25-30	M10	40-50
LCVT550AL-525	394	291	470	435	75	325	142	83	2xM12	25-30	M10	40-50
<b>ACU610</b>												
LCVT160AL-690	360	220	284	310	65	325	124	50	M8	15-20	M8	20-25
LCVT200AL-690	394	221	343	381	74	325	127	65	M10	25-30	M8	20-25
LCVT250AL-690	394	221	394	433	74	325	126	73	M10	25-30	M8	20-25
LCVT320AL-690	465	291	517	515	87	400	143	110	2xM12	25-30	M10	40-50
LCVT360AL-690	465	291	517	515	86	400	143	105	2xM12	25-30	M10	40-50
LCVT410AL-690	465	291	517	515	87	400	143	112	2xM12	25-30	M10	40-50



# EMC FILTERS

Because of their intrinsic characteristics, all frequency inverters often generate undesired high frequency voltages generally referred to as “interference”. EMC filters are installed on the mains side to reduce this interference. The reference standard EN EN61800-3 defines the thresholds for electromagnetic interference for different classes of equipment.

Active Cube series frequency inverters up to size 9.2 kW can be ordered with a built-in EMC filter conforming to the requirements of the standard for “Category C2” environments.

Two series of external EMC filters are available for larger size Active Cube frequency inverters and for installations where conformity to the requirement “Category C1” necessary. The two series differ both in construction and power range.

The first set of filters are “backplate filters or foot print”. They are available in sizes 7 to 40 A (suitable for Active Cube frequency inverters up to size 4), and allow the frequency inverter to be installed on board the filter itself. The second series of filters are “book filters”. They cover all other Active Cube sizes up to 630 A and are designed for installation on the same mounting panel alongside the drive.

Mains filters with very low dispersion currents are available upon request for specific applications.

Basic circuit diagram

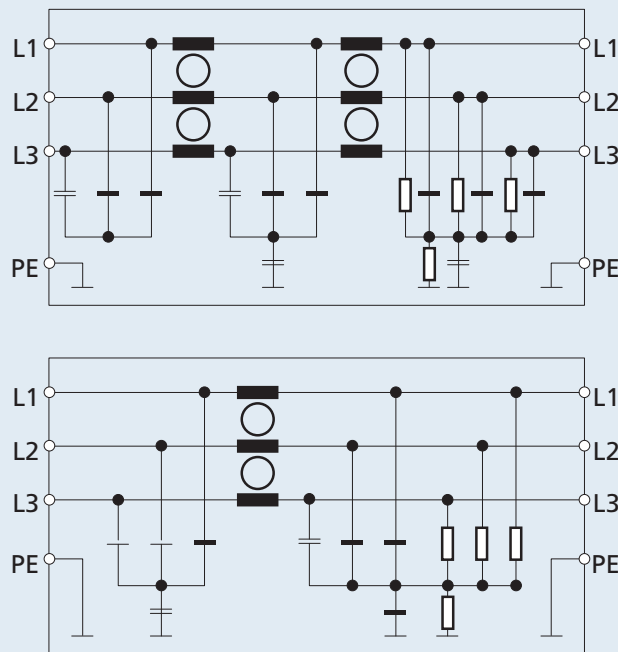

# BACKPLATE EMC FILTERS

## Mains voltage

- 3 x 480V~ maximum +10%

## Nominal current

- 8A ... 40A

## Frequency

- 50/60 Hz

## Operating and storage temperature

- -25 °C ... +100 °C (climate class acc. to EN60721-3-3)

## Ambient temperature

- +40°C maximum

## Protection degree (EN 60529)

- IP00

## Connection type

- Contact-protected terminals
- Strand connection on load side (only up to ACU 410-18)
- Metal fasteners are included in the supply

## Note

These mains filters are installed between the line choke and the frequency inverter. The frequency inverter installed on the EMC filter must be connected to the metal baseplate with a short, large section earth connection.

Overload capacity is 1.5 times rated current for 1 minute, every 30 minutes.

Inverter type		EMC filter	Rated current	Leakage current	Power dissipation	Weight
Size	Type		[A]	[mA]	[W]	[kg]
3	<b>ACU 410-19</b>	FTV018B	18	1.5	20	3.5
	<b>ACU 410-21</b>					
4	<b>ACU 410-23</b>	FTV040B	40	1.2	35	3.5
	<b>ACU 410-25</b>					

## Dimensions FTV018B - FTV040B

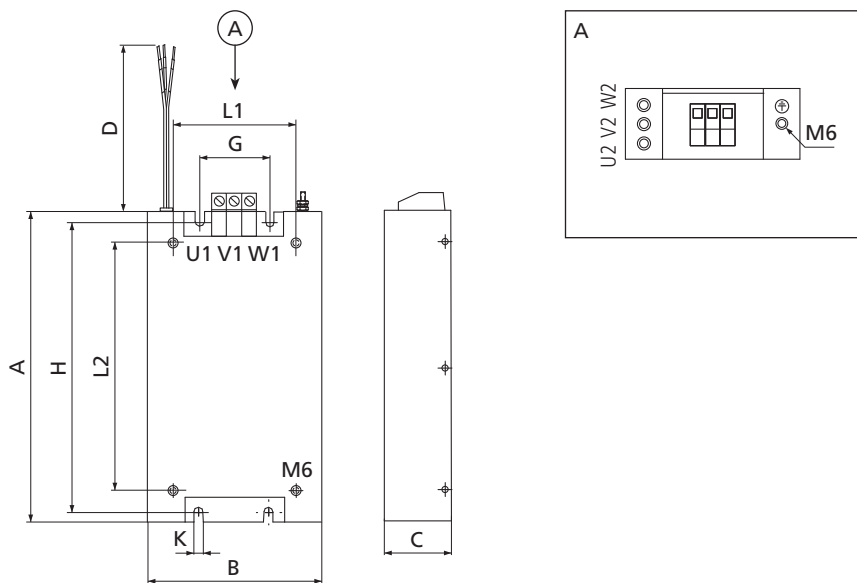

EMC filter	A	B	C	D	G	H	K	L1	L2
FTV018B	315	100	65	300	35	300	6.3	76	270
FTV040B	315	125	65	300	60	300	6.3	125	270

# BOOK TYPE EMC FILTERS

## Mains voltage

- 3 x 480 VAC

## Rated current

- 7 A ... 630 A

## Frequency

- up to 60 Hz

## Operating and storage temperature

- -25 °C ... +80 °C (climate class acc. to EN60721-3-3)

## Protection degree (EN 60529)

- IP20

## Maximum length of motor cables:

- ACU 410-01 to -15: 25 m class B
- ACU 410-18 to -25: 50 m class B
- ACU 410-27 to -39: 10 m class B, 100 m class A group 1
- ACU 410-43 to -49: 10 m class B, 100 m class A group 1

## Note

Overload capacity is 4 times rated current at switch-on; 1.5 times rated current for 1 minute, once per hour.

Inverter type		EMC filter	Rated current	Leakage current	Power dissipation	Weight
Size	Type		[A]	[mA]	[W]	[kg]
1	ACU 210-01	HLD 110-500/8	8	20	6	0.8
	ACU 210-03					
	ACU 210-05					
	ACU 210-07					
	ACU 210-09					
	ACU 410-01					
	ACU 410-03					
	ACU 410-05					
	ACU 410-07					
	ACU 410-09					
	ACU 410-11					
2	ACU 210-11	HLD 110-500/16	16	21	12	1.2
	ACU 410-12					
	ACU 410-13					
	ACU 410-15					
	ACU 210-13					
	ACU 210-15					
3	ACU 410-18	HLD 110-500/30	30	29	15	1.6
	ACU 410-19					
	ACU 410-21					
	ACU 210-18					
4	ACU 210-19	HLD 110-500/42	42	30	22	2.0
	ACU 410-22					
	ACU 210-21					
	ACU 410-23					
	ACU 410-25					
	ACU 210-22					

Inverter type		EMC filter	Rated current	Leakage current	Power dissipation	Weight	
Size	Type		[A]	[mA]	[W]	[kg]	
5	<b>ACU 410-27</b>	HLD 110-500/42	42	30	22	2.0	
	<b>ACU 410-29</b>	HLD 110-500/55	55	30	30	2.6	
	<b>ACU 410-31</b>	HLD 110-500/75	75	22	35	3.8	
6	<b>ACU 410-33</b>	HLD 110-500/100	100	30	60	5.1	
	<b>ACU 410-35</b>						
	<b>ACU 410-37</b>	HLD 110-500/130	130	22	90	5.6	
	<b>ACU 410-39</b>						
7	<b>ACU 410-43</b>	HLD 110-500/180	180	31	150	9.5	
	<b>ACU 410-45</b>						
	<b>ACU 410-47</b>	HLD 110-500/250	250	37	180	12.7	
	<b>ACU 410-49</b>						
8	<b>ACU410-51</b>	FTV401A	400	42	55	12.2	
	<b>ACU410-53</b>						
	<b>ACU410-55</b>						
	<b>ACU410-57</b>	FTV630A	630		65	17.8	
	<b>ACU410-59</b>						
	<b>ACU410-61</b>						
	<b>ACU510-51</b>	FTV401A	400		55	12.2	
	<b>ACU510-53</b>						
	<b>ACU510-55</b>						
	<b>ACU510-57</b>	FTV630A	630		65	17.8	
	<b>ACU510-59</b>						
	<b>ACU510-61</b>						
	<b>ACU610-51</b>	FTV400A-690	400		17	55	11.0
	<b>ACU610-53</b>						
<b>ACU610-55</b>							
<b>ACU610-57</b>							
<b>ACU610-59</b>							
<b>ACU610-61</b>							



# BOOK TYPE EMC FILTERS

Dimensions HLD 110-500/8 ... HLD 110-500/250

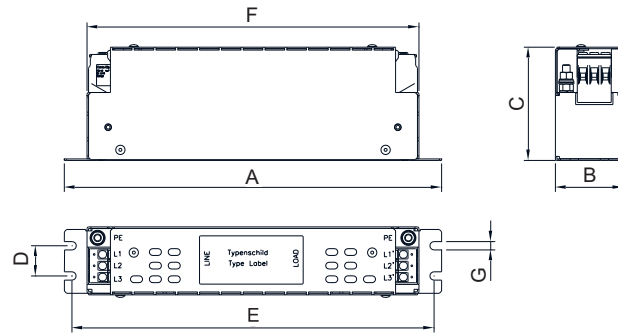

EMC filter	A	B	C	D	E	F	G
HLD 110-500/8	190	45	75	20	180	166	M5
HLD 110-500/16	250	45	75	20	240	220	M5
HLD 110-500/30	270	55	95	30	255	240	M5
HLD 110-500/55	250	85	95	60	235	255	M5
HLD 110-500/75	270	85	135	60	255	310	M6
HLD 110-500/100	270	95	150	65	255	325	M6
HLD 110-500/130	270	95	150	65	255	325	M6
HLD 110-500/180	380	130	181	102	365	440	M6
HLD 110-500/250	450	155	220	125	435	525	M6

## Dimensions FTV401A ... FTV630A

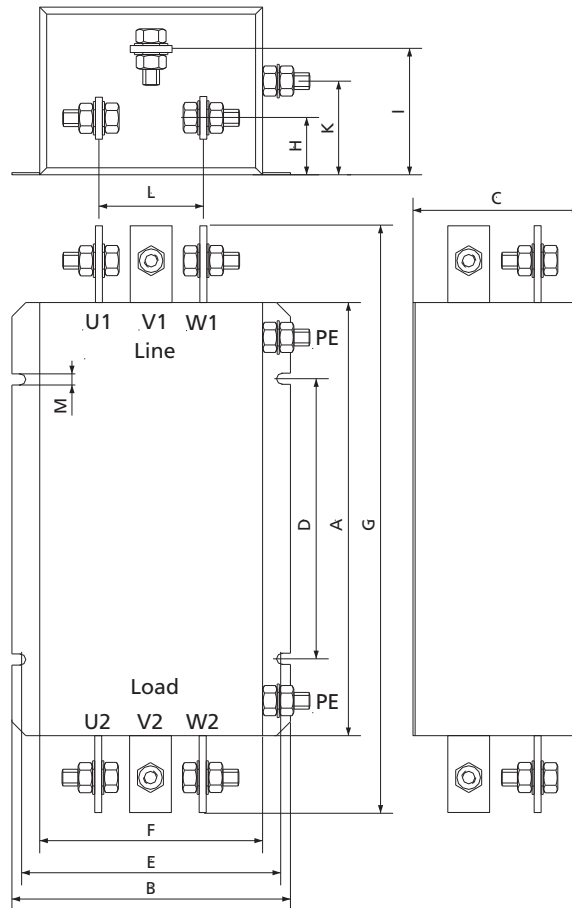

EMC filter	A	B	C	D	E	M $\varnothing$	F	G	PE	H	I	K	L	Bus Bar
FTV401A	350	240	150	200	220	M8	200	480	M12	69	110	30	128	8x25 M10
FTV400A-690	350	240	150	200	220	M8	200	480	M12	69	110	30	128	8x25 M10
FTV630A	350	240	150	200	220	M8	200	480	M12	69	110	30	128	8x25 M10

# BRAKING RESISTORS

When speed of an inverter-controlled AC motor is reduced, the motor acts as a generator, feeding back energy to the frequency inverter. As a result, voltage in the intermediate circuit of the inverter increases. When a specific threshold is exceeded, the energy must flow to an external braking system in order to avoid drive failures. Braking resistors are designed to absorb such energy and to dissipate it into heating. The use of brake resistors allows drives to fulfil the requirements of particularly severe duty cycles, for example those featured by frequent braking, long lasting braking or impulsive braking.

Bonfiglioli offers a wide range of safe and compact braking resistors with IP20 degree of protection: "BR series".

BR series are designed for panel mounting.

Depending on the brake resistors these are equipped with a thermal switch (see selection table for details).

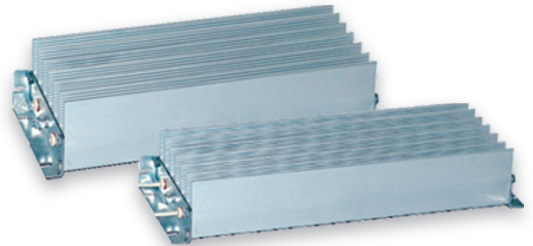

## Connection diagram

$R_B$  = external braking resistor

Bch = brake chopper integrated in standard Active Cube inverter

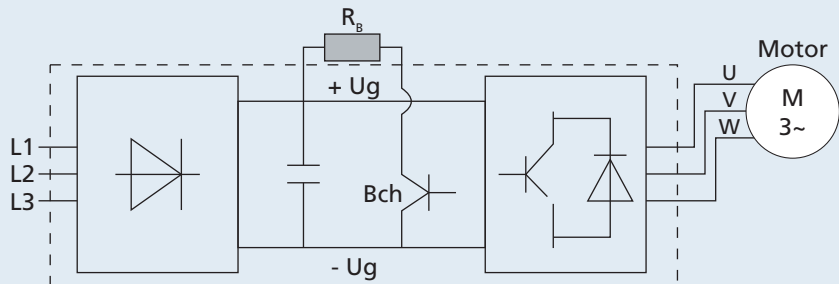

## Connection terminals

The  $R_{b1}$  and  $R_{b2}$  braking resistor terminals on AxiaVert frequency inverters are located on the X2 power output terminal strip. Access to these terminals on sizes 1 to 4 units is made even easier by the use of disconnectable power terminal strips. Refer to the manual provided with your frequency inverter for further details on materials and connection methods.

### Frequency inverter (from 0.25 to 4.0 kW)

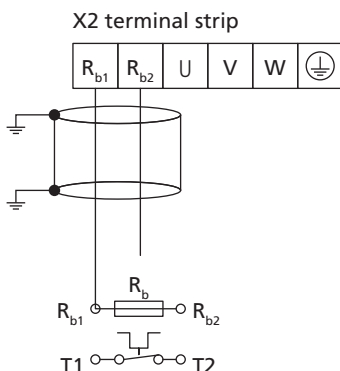

### Frequency inverter (from 5.5 to 132 kW)

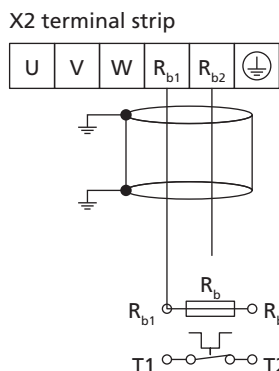

## Active Cube drive combination chart

These charts show recommended combinations for each model in the Active Cube range, and specify the corresponding duty cycles on the basis of rated drive power. Contact your nearest Bonfiglioli Drive Centre for particularly heavy-duty braking applications or if you need to customise a product.

Inverter type	Bonfiglioli braking resistor	Resistance	Continuous rated power	Duty cycle at the drive's rated power	
kW		Ohm	[W]	[%]	
ACU 210-01	0.25	BR 160/100	100	160	64%
ACU 210-03	0.37	BR 160/100	100	160	43%
ACU 210-05	0.55	BR 160/100	100	160	29%
ACU 210-07	0.75	BR 160/100	100	160	21%
ACU 210-09	1.1	BR 160/100	100	160	15%
ACU 210-11	1.5	BR 432/37	37	432	29%
ACU 210-13	2.2	BR 432/37	37	432	20%
ACU 210-15	3	BR 432/37	37	432	14%
ACU 210-18	4	BR 667/24	24	667	17%
ACU 210-19	5.5	BR 667/24	24	667	12%
ACU 210-21	7.5	BR 1333/12	12	1333	18%
ACU 210-22	9.2	BR 1333/12	12	1333	14%
ACU 410-01	0.25	BR 213/300	300	213	85%
ACU 410-03	0.37	BR 213/300	300	213	57%
ACU 410-05	0.55	BR 213/300	300	213	39%
ACU 410-07	0.75	BR 213/300	300	213	28%
ACU 410-09	1.1	BR 213/300	300	213	19%
ACU 410-11	1.5	BR 213/300	300	213	14%
ACU 410-12	1.85	BR 471/136	136	471	25%
ACU 410-13	2.2	BR 471/136	136	471	21%
ACU 410-15	3	BR 471/136	136	471	16%
ACU 410-18	4	BR 696/92	92	696	17%
ACU 410-19	5.5	BR 1330/48	48	1330	24%
ACU 410-21	7.5	BR 1330/48	48	1330	18%
ACU 410-22	9.2	BR 1330/48	48	1330	14%
ACU 410-23	11	BR 2000/32	32	2000	18%
ACU 410-25	15	BR 2000/32	32	2000	13%
ACU 410-27	18.5	BR 4000/16	16	4000	22%
ACU 410-29	22	BR 4000/16	16	4000	18%
ACU 410-31	30	BR 4000/16	16	4000	13%
ACU 410-33	37	BR 8000/7	7.5	8000	22%
ACU 410-35	45	BR 8000/7	7.5	8000	18%
ACU 410-37	55	BR 8000/7	7.5	8000	15%
ACU 410-39	65	BR 8000/7	7.5	8000	12%
ACU 410-43	75	BR8000/7	7.5	8000	11%
ACU 410-45	90	BR8000/7	7.5	8000	9%
ACU 410-47	110	2xBR8000/7	3.75	16000	15%
ACU 410-49	132	2xBR8000/7	3.75	16000	12%

For further information refer to the Bonfiglioli braking resistor catalogue.



# OUR GLOBAL PRESENCE

Thanks to an international network of closely interconnected commercial and production sites, we can guarantee the same high standards of Bonfiglioli quality anywhere at any given time. We know that our direct presence in local markets is the key to long-lasting success, so our family includes 17 production sites, 23 commercial sites and more than 550 distributors around the world.

Our organization is always close by, offering complete and efficient solutions and supporting our customers with dedicated services, co-engineering and after-sales assistance.



**17**  
PRODUCTION SITES



**23**  
COMMERCIAL SITES



**80**  
COUNTRIES



**550**  
DISTRIBUTORS



**~5,000**  
PEOPLE

## AUSTRALIA

### Bonfiglioli Transmission (Aust.) Pty Ltd

2, Cox Place Glendenning NSW 2761  
Locked Bag 1000 Plumpton NSW 2761  
Tel. +61 2 8811 8000



## BRAZIL

### Bonfiglioli Redutores do Brasil Ltda

Av. Osvaldo Fregonezi, 171, cjs 31 e 44  
CEP 09851-015 - São Bernardo do Campo  
São Paulo  
Tel. +55 11 4344 2322



## CHINA

### Bonfiglioli Drives (Shanghai) Co. Ltd.

#68, Hui-Lian Road, QingPu District,  
201707 Shanghai  
Tel. +86 21 6700 2000



### Selcom Electronics (Shanghai) Co., Ltd

A7, No.5399, Waiqingsong Road, QingPu  
District,  
201707 Shanghai  
Tel. +86 21 6010 8100



A24, No.5399, Waiqingsong Road, QingPu  
District,  
201707 Shanghai

Tel. +86 21 6010 8100



## FRANCE

### Bonfiglioli Transmission S.A.S.

14 Rue Eugène Pottier  
Zone Industrielle de Moimont II  
95670 Marly la Ville  
Tel. +33 1 34474510



## GERMANY

### Bonfiglioli Deutschland GmbH

Sperberweg 12 - 41468 Neuss  
Tel. +49 0 2131 2988 0



### Bonfiglioli Deutschland GmbH

Europark Fichtenhain B6 - 47807 Krefeld  
Tel. +49 0 2151 8396 0



### O&K Antriebstechnik GmbH

Ruhrallee 8-12 - 45525 Hattingen  
Tel. +49 0 2324 2050 1



## INDIA

### Bonfiglioli Transmission Ltd.

#### Mobility & Wind Industries

AC 7 - 11, SIDCO Industrial Estate,  
Thirumudivakkam  
Kancheepuram - 600132 - Tamil Nadu  
Tel. +91 844 844 8649



#### Industry & Automation Solutions

Survey No. 528/1, Perambakkam High Road  
Mannur Village, Sriperumbudur Taluk  
Kancheepuram - 602 105 - Tamil Nadu  
Tel. +91 844 844 8649



#### Industry & Automation Solutions

Plot No E-5/2, Badhalwadi  
Talegaon MIDC Phase II,  
Pune - 410 507 - Maharashtra  
Tel. +91 844 844 8649



## ITALY

### Bonfiglioli Riduttori S.p.A.

#### Industry & Automation Solutions

Via Cav. Clementino Bonfiglioli, 1  
40012 Calderara di Reno  
Tel. +39 051 6473111



#### Industry & Automation Solutions

Via Sandro Pertini, lotto 7b  
20080 Carpiano  
Tel. +39 02985081



#### Mobility & Wind Industries

Via Enrico Mattei, 12 Z.I. Villa Selva  
47122 Forlì  
Tel. +39 0543 789111



#### Industry & Automation Solutions

Via Unione, 49 - 38068 Rovereto  
Tel. +39 0464 443435/36



### Selcom Group S.p.A.

Via Achille Grandi, 5  
40013 Castel Maggiore (BO)  
Tel. +39 051 6387111



Via Marino Serenari, 18

40013 Castel Maggiore (BO)  
Tel. +39 051 6387111



Via Cadriano, 19

40057 Cadriano (BO)  
Tel. +39 051 6387111



## NEW ZEALAND

### Bonfiglioli Transmission (Aust.) Pty Ltd

88 Hastie Avenue, Mangere Bridge,  
2022 Auckland  
PO Box 11795, Ellerslie  
Tel. +64 09 634 6441



## SINGAPORE

### Bonfiglioli South East Asia Pte Ltd

8 Boon Lay Way, #04-09,  
8@ Tadehub 21, Singapore 609964  
Tel. +65 6268 9869



## SLOVAKIA

### Bonfiglioli Slovakia s.r.o.

Robotnícka 2129  
Považská Bystrica, 01701 Slovakia  
Tel. +421 42 430 75 64



## SOUTH AFRICA

### Bonfiglioli South Africa Pty Ltd.

55 Galaxy Avenue, Linbro Business Park,  
Sandton, Johannesburg  
2090 South Africa  
Tel. +27 11 608 2030



## SPAIN

### Tecnotrans Bonfiglioli S.A

Avinguda del Ferrocarril, nº 14,  
Polígono Industrial Can Estapé  
08755 Castellbisbal - Barcelona  
Tel. +34 93 447 84 00



## TURKEY

### Bonfiglioli Türkiye Jsc

Atatürk Organize Sanayi Bölgesi,  
10007 Sk. No. 30  
Atatürk Organize Sanayi Bölgesi,  
35620 Çiğli - Izmir  
Tel. +90 0 232 328 22 77



## UNITED KINGDOM

### Bonfiglioli UK Ltd.

Unit 1 Calver Quay, Calver Road, Winwick  
Warrington, Cheshire - WA2 8UD  
Tel. +44 1925 852667



## USA

### Bonfiglioli USA Inc.

3541 Hargrave Drive  
Hebron, Kentucky 41048  
Tel. +1 859 334 3333



## VIETNAM

### Bonfiglioli Vietnam Co. Ltd.

Lot C-9D-CN, My Phuoc 3 Industrial Park,  
Thoi Hoa ward, Ben Cat city, Binh Duong  
province, Vietnam  
Tel. +84 274 3577411





We have a relentless commitment to excellence, innovation & sustainability. Our team creates, distributes and services world-class power transmission & drive solutions to keep the world in motion.

#### HEADQUARTERS

##### Bonfiglioli S.p.A

Via Cav. Clementino Bonfiglioli, 1  
40012 Calderara di Reno - Bologna (Italy)  
Tel. +39 051 6473111

