



AXIAVERT SERIES

Premium drive

 **Bonfiglioli**

CONTENTS

THE HIGHEST LEVEL OF PRECISION, EFFICIENCY AND ENERGY OPTIMIZATION.....	4
A COMPLETE INTEGRATED SOLUTION FOR ALL INDUSTRIAL APPLICATIONS.....	5
BONFIGLIOLI DIGITAL TOOLS.....	6
BONFIGLIOLI FREQUENCY INVERTERS AND SERVO DRIVES.....	7
AXIAVERT SERIES	8
APPLICATIONS.....	9
AXIAVERT SYSTEM RANGE.....	10
AXIAVERT KEY FEATURES AND BENEFITS.....	11
AXIAVERT ORDER & DESIGNATION CODE.....	12
MODULAR SYSTEM (OPTIONS OVERVIEW).....	14
AXIAVERT SPECIFICATIONS (FEATURES ALWAYS ONBOARD).....	15
AXIAVERT FUNCTIONAL SAFETY.....	16
AXIAVERT CONNECTIVITY.....	18
AXIAMANAGER	19
AXIAMANAGER PLC.....	22
COMMUNICATION MODULES.....	23
KEYPAD AND USB CONNECTIONS.....	24
ENCODER MODULES.....	25
GENERAL TECHNICAL DATA.....	27
AXV20 Technical Data (from 0.25 to 3.0 kW).....	28
AXV20 Technical Data (from 4.0 to 9.2 kW).....	29
AXV40 Technical Data (from 0.25 to 1.5 kW).....	30
AXV40 Technical Data (from 1.85 to 4.0 kW).....	31
AXV40 Technical Data (from 5.5 to 15.0 kW).....	32
CONTROL TERMINALS.....	33
FUNCTIONAL SAFETY TERMINALS.....	34
MOUNTING OF STANDARD DEVICES.....	35
Mounting of Frame Size 1.....	36
Mounting of Frame Size 2.....	37
Mounting of Frame Size 3.....	38
Mounting of Frame Size 4.....	39
EMC OVERVIEW.....	40
FERRITE CORE.....	42
LINE CHOKE.....	44
EMI FILTERS.....	48
BACKPLATE EMI FILTERS.....	49
BOOK TYPE EMI FILTERS.....	51
BRAKING RESISTORS.....	53
GLOBAL PRESENCE.....	56

THE HIGHEST LEVEL OF PRECISION, EFFICIENCY AND ENERGY OPTIMIZATION

With more than 20 years of experience in creating tailored and forward-thinking motion control systems, Bonfiglioli has proven to be a reliable partner as **one-stop shop for mechatronic applications** in industrial automation.

Bonfiglioli engineering specialists work side by side with customers to develop dedicated integrated solutions, covering the entire motion drive train according to an **Industry 4.0 approach**.

Thanks to the extensive know-how and the long-term collaboration with key customers, our centers of excellence develop **breakthrough mechatronic innovations**, including low-backlash planetary gearboxes, servomotors, open-loop and closed-loop inverters, servo drives and energy regenerative units.

This, combined with a comprehensive range of **Professional Services**, enables us to respond to customers' requests by:

- providing **user-friendly, plug & play solutions**
- **increasing** applications' **efficiency** and **productivity**
- designing **flexible, modular solutions** targeted to a wide range of applications
- granting access to real-time data for **diagnostic, maintenance** and **predictive analytics**



ASSESSMENT &
RECOMMENDATION



ENGINEERING &
PLANNING



INSTALLATION &
COMMISSIONING



RETROFIT &
UPGRADE



MAINTENANCE &
REPAIR

FULLY COMMITTED TO EFFICIENCY

Bonfiglioli technical sales experts support customers with a proactive, flexible and dedicated approach **throughout the system's entire life cycle**.

- **Assessment and recommendation:** our team provides support starting from the very early stage of the project by assessing the requirements and developing a targeted analysis of the application, guiding customers in the choice of the most suitable components for their drive solution.
- **Engineering and planning:** our experts work with customers to co-engineer their application, offering consultancy in sizing, fine tuning and selecting the optimized drive train, always considering life cycle cost optimization.
- **Installation and commissioning:** we partner with our customers to ensure a quick, cost-effective and successful installation, optimizing the benefits and functions of their drive technology.
- **Retrofit and upgrade:** we update customers' machines with state-of-the-art technology to ensure constant levels of productivity, reliability and performance.
- **Maintenance and repair:** we work side by side with customers to avoid failures, reduce downtimes and ensure the best system operation.

A COMPLETE INTEGRATED SOLUTION FOR ALL INDUSTRIAL APPLICATIONS

Our engineering specialists **work side by side with customers** to create the most effective solution, whether the request is to optimize an existing machine or to develop a new one. Our relationship with customers is based on an **active partnership** with fast decision-making processes to develop individually tailored offers. Our full-range and modular offering provides the necessary products for the development of vertically integrated solutions in **a variety of sectors**, such as material handling, automated storage, textile and packaging. Our team of experts assists customers in designing cost-effective and energy-efficient machines, aligning performance to meet the specific requirements.



A COMPLETE INTEGRATED SOLUTION

- Precision Planetary Gearboxes
- Industrial Gearboxes
- Permanent Magnet Synchronous Motors
- Synchronous Reluctance Motors
- Asynchronous Motors
- Servo Drives
- Frequency Inverters
- Energy Regenerative Inverters
- Motion Control
- Industry 4.0 solutions

INDUSTRY SECTOR EXPERTISE



MATERIAL HANDLING



HOIST & CRANES



FOOD & BEVERAGE



AUTOMATED WAREHOUSE



PACKAGING



TEXTILES



MATERIAL WORKING

BONFIGLIOLI DIGITAL TOOLS

Thanks to a powerful set of **software tools** and **online platforms**, developed through partnerships with the main market leaders, Bonfiglioli enables its customers to **engineer tailored applications** in a smooth and productive way: the components selection and sizing, as well as the design of the whole motion drive train, are made simpler and more reliable.

In addition, thanks to its in-depth knowledge of industrial solutions, **Bonfiglioli engineering team is ready to assist customers** in their selection and design process, providing high quality technical support for specific application developments.



SERVO SOFT DEVELOP OPTIMIZED SOLUTIONS

Bonfiglioli and SERVOsoft® work together to **support customers in sizing complete multi-axis servo systems**, including motors, gearboxes and servodrives with 15 mechanisms and up to 50 axes in a shared bus or standalone configuration.

With the Bonfiglioli products available on SERVOsoft, customers are able to select, dimension and design their customized and high performance applications. In addition, the Bonfiglioli engineering team, uses the high-level servosizing tool SERVOsoft® to provide a **top-level customer support** service by developing **optimized, energy-efficient and tailored engineering solutions** to meet individual needs.



SHOP PRODUCT CONFIGURATION AND ORDER ASSISTANT

Bonfiglioli's **complete e-business system** guides customers, distributors and agents through the process of **selecting the right product** for their specific needs, and provides support for **design activities and order management**, greatly accelerating the selection and ordering process and improving accuracy. Thanks to this web-based technology, customers can get in touch with Bonfiglioli technical service anytime from anywhere around the world.



EPLAN ENHANCE YOUR ELECTRICAL DESIGN

Bonfiglioli and EPLAN work together to **provide efficient engineering solutions**, aimed at reducing the gap between the initial concept and its development, programming and commissioning, thanks to:

- Always up-to-date device data and documentation
- Easy drag-and-drop function to develop optimized electrical drawings.

BONFIGLIOLI FREQUENCY INVERTERS AND SERVO DRIVES

THE RIGHT SOLUTION FOR A WIDE SPECTRUM OF APPLICATIONS

Our wide portfolio of frequency inverters and servo drives provides **unprecedented levels of flexibility** across a variety of sectors:

- compatibility with a wide range of motors types
- scalable control performances from basic to demanding applications
- wide power range (from 0.25 to 1,200 kW)
- extensive input/output connectivity
- support of major fieldbus protocols.

Whether in the textile industry, packaging, material working, automated storage or other sectors, our frequency inverters and servo drives are **optimized for numerous applications**.

Our team of experts constantly works with the aim of providing **innovative and highly performant solutions**, introducing continuous improvements in terms of better control of your processes, lower energy consumption, improved productivity and user experience.

HIGHEST ENERGY EFFICIENCY

Our frequency inverters and servo drives portfolio fulfil the **highest IE2 efficiency class** in compliance with the **EN 61800-9-2 EcoDesign** regulation, for the reduction of energy consumption and the impact on the environment connected to industrial production.

Our drives give a major contribution to **energy consumption optimization and to energy saving** in the entire plant. Several **included functions** are available through parameter setup, allowing to reduce the electrical energy needed to power motors, such as standby mode and automatic flux reduction.

TOP-LEVEL USER EXPERIENCE

All our drives provide **intuitive engineering software** and **user-friendly programming interfaces** for parameter setting, diagnostic and supported commissioning.

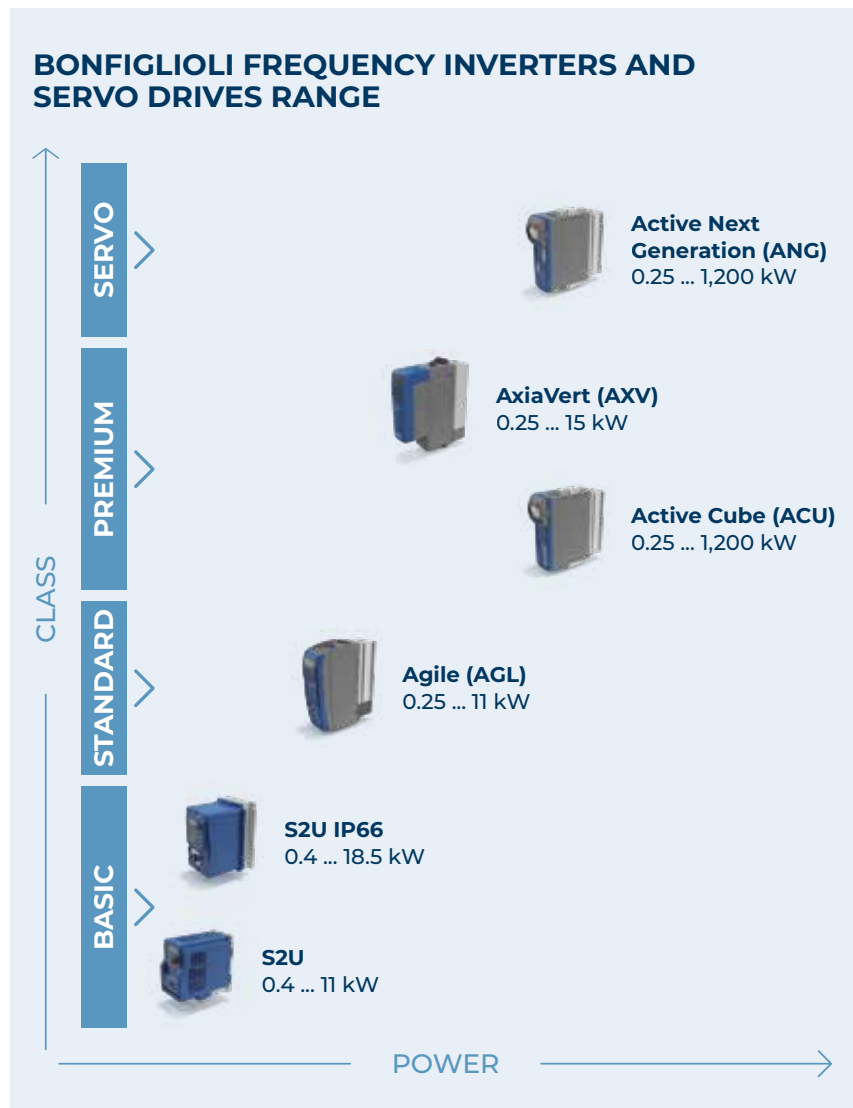

AXIAVERT SERIES

Bonfiglioli AxiaVert (AXV) series is designed to allow **great flexibility** and **top-level performance**, making it suitable for a **wide range of applications**. Thanks to its modular system, the AxiaVert series offers integrated Functional Safety, optional encoder evaluation (including digital encoders like Hiperface DSL and EnDat 2.2) and open communication protocols complying with Industry 4.0 standards and an intuitive GUI for commissioning and monitoring.

The series includes:

- 3 phase 400V mains: 0.25 - 15 kW
- 3 phase 230V mains: 0.25 - 9.2 kW (in preparation)
- 1 phase 230V mains: 0.25 - 3 kW (in preparation)



APPLICATIONS

THE HIGHLY FLEXIBLE AND MODULAR AUTOMATION SYSTEM FOR A WIDE SPECTRUM OF APPLICATIONS

Whether in material working, logistics, automated storage, packaging or textile industries, the frequency inverters of the AxiaVert series are **optimized for numerous applications**.

Thanks to its **modular structure**, the system can be **flexibly adapted** to meet highly diversified requirements. Machine designs allow great freedom in the selection of hardware modules and accessories, together with fully customizable software functionalities.

In addition, the AxiaVert series is characterized by **great process versatility** thanks to high compatibility with a wide range of motors (asynchronous, permanent magnet synchronous, synchronous reluctance) and the possibility to select reliable embedded motion and control features, making the drive optimal for many different applications.

Our offer expands far beyond standard, providing the **right solutions tailored to the most demanding customers' requirements**.

WOODWORKING

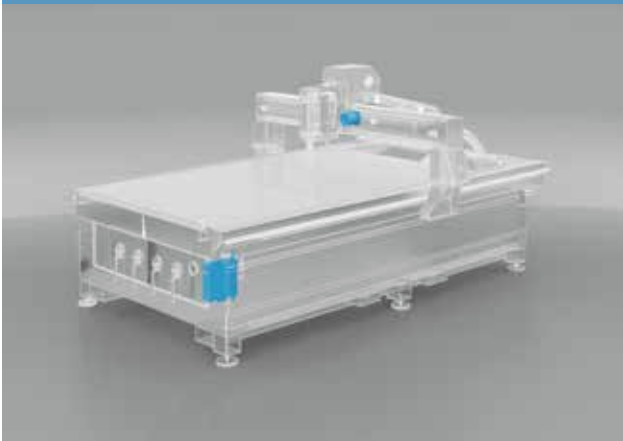

HOISTS AND CRANES



AUTOMATED STORAGE



TEXTILE

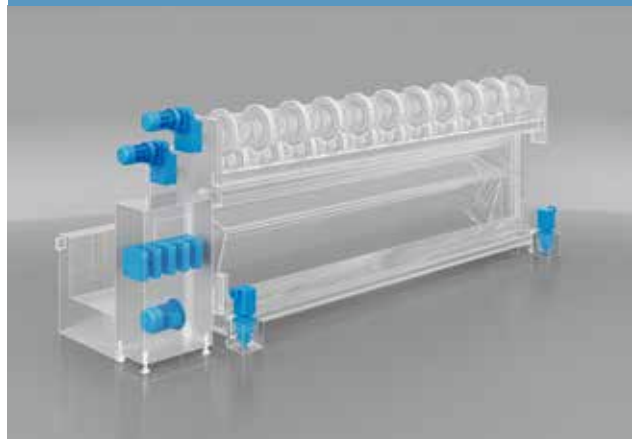

AXIAVERT SYSTEM RANGE

DEVELOP YOUR OPTIMIZED, FULLY INTEGRATED SOLUTION WITH AXIAVERT AND THE COMPLETE PRODUCT RANGE FROM BONFIGLIOLI

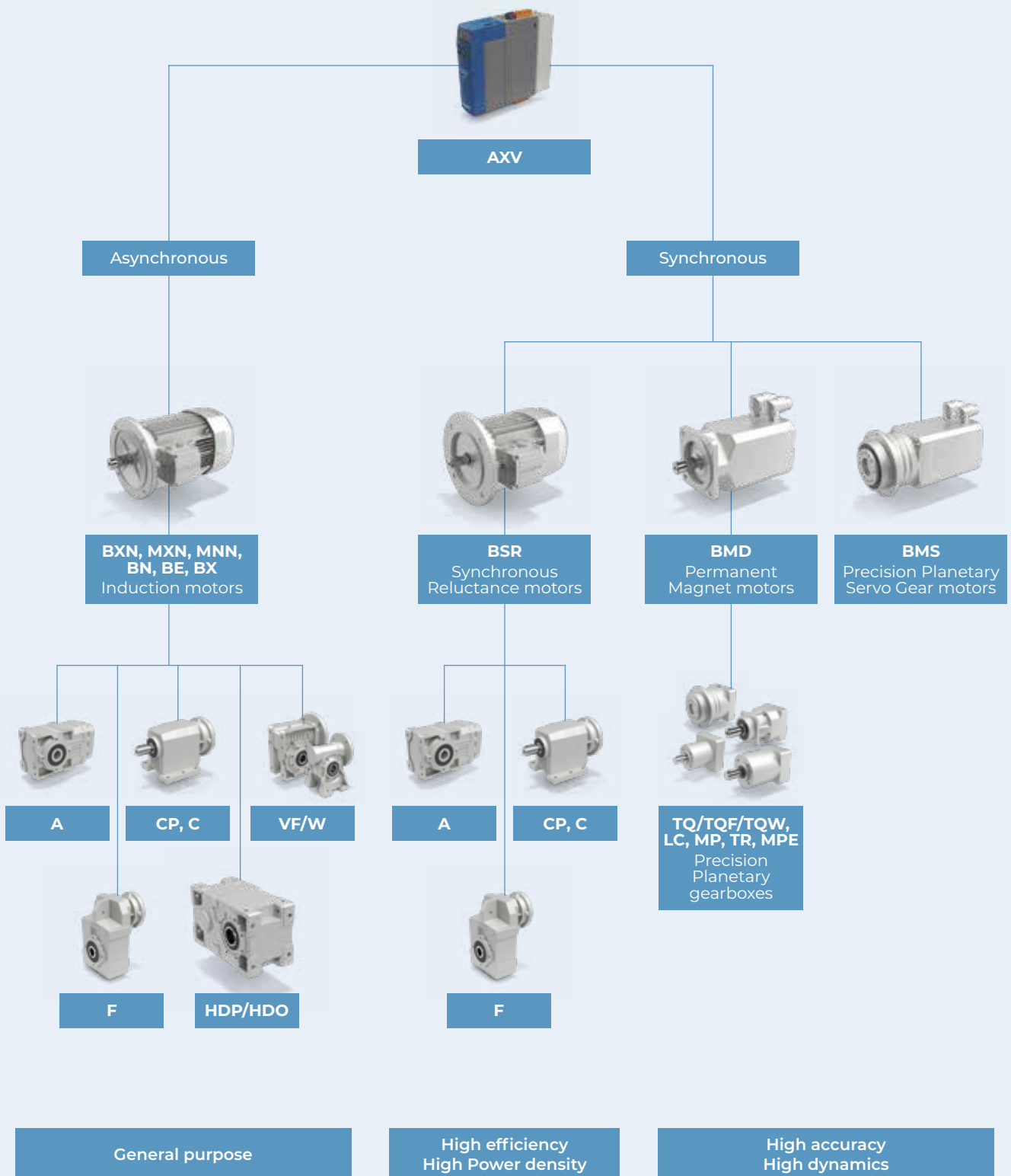

AXIAVERT KEY FEATURES AND BENEFITS

THE TOP-LEVEL FUNCTIONAL SAFETY, HIGH CONTROL PERFORMANCE, IIoT-READY SOLUTION FOR A WIDE SPECTRUM OF APPLICATIONS

In order to be able to respond to the specific requirements of applications across sectors and to different degrees of complexity, the AxiaVert series offers a complete set of modular and flexible features and functionalities:



FLEXIBLE COMMUNICATION PROTOCOLS COMPLYING WITH AUTOMATION AND INDUSTRY 4.0 STANDARDS

Smooth integration into automation networks thanks to the **compatibility with a wide range of fieldbus protocols and machine controllers**.
Dedicated communication and monitoring functions fostering the **optimization of production** and **increasing the efficiency** of the entire applications in accordance with Industry 4.0 standards.



WIDE RANGE OF ADVANCED INTEGRATED FUNCTIONAL SAFETY CAPABILITIES

The **different Functional Safety variants** allow selecting the most suitable variant in terms of costs and performance to match the functions actually needed. This approach **optimizes the configuration**, reduces the need for external safety components and installation space while ensuring a **safe and controlled operation** of all kind of applications, minimizing hazardous states, and hence damage to persons, property and environment.



HIGH ACCURACY IN SPEED, POSITION AND TORQUE CONTROL WITH OR WITHOUT ENCODER FEEDBACK

The smooth and accurate motion control for **open-loop and closed-loop applications** maximizes the machine efficiency and productivity. Therefore, manufacturing capabilities are expanded **for a wide range of motion requirements**, including high speed motors, multi-feedback and multi-motor applications.



WIDE RANGE OF OPTION MODULES, IEC 61131-3 PLC PROGRAMMING

Thanks to its **modular structure**, the system can be flexibly adapted to meet many different application requirements by selecting the suitable hardware modules and accessories, combining the embedded standard software functionalities and **customizing the operational behavior as needed, through user-level PLC software programmability**.



INTEGRATED DEVICE AND APPLICATION MONITORING

Diagnostics, alarm management, predictive maintenance on the motion chain components and at machine level, allowing:

- reduction in maintenance costs
- reduction in machine failures and downtime
- lower stock of spare parts
- longer service life of parts
- increased efficiency and productivity
- improved operator safety



SUPPORTED CONTROL OF WIDE RANGE OF MOTOR TYPES WITH HIGH-VALUE MOTION AND CONTROL FEATURES

Great process versatility thanks to **high compatibility with a wide range of motors** (asynchronous, permanent magnet synchronous, synchronous reluctance) and the possibility to select **reliable embedded motion and control features**, making the drive optimal for many different applications.



GRAPHICAL USER INTERFACE FOR PC AND MOBILE DEVICES, WIRED AND WIRELESS CONNECTIVITY (USB, BLUETOOTH), GRAPHICAL KEYPAD

High-end user experience thanks to user friendly graphic interfaces, allowing the **guided startup, commissioning and tuning** of the inverter, the motion chain components and the application, **in both online and offline mode**, also in wireless and mobile connection. Performance monitoring, optimization and servicing also from remote location. High level of security and simplicity in device management thanks to the availability of different access levels and user profiles.

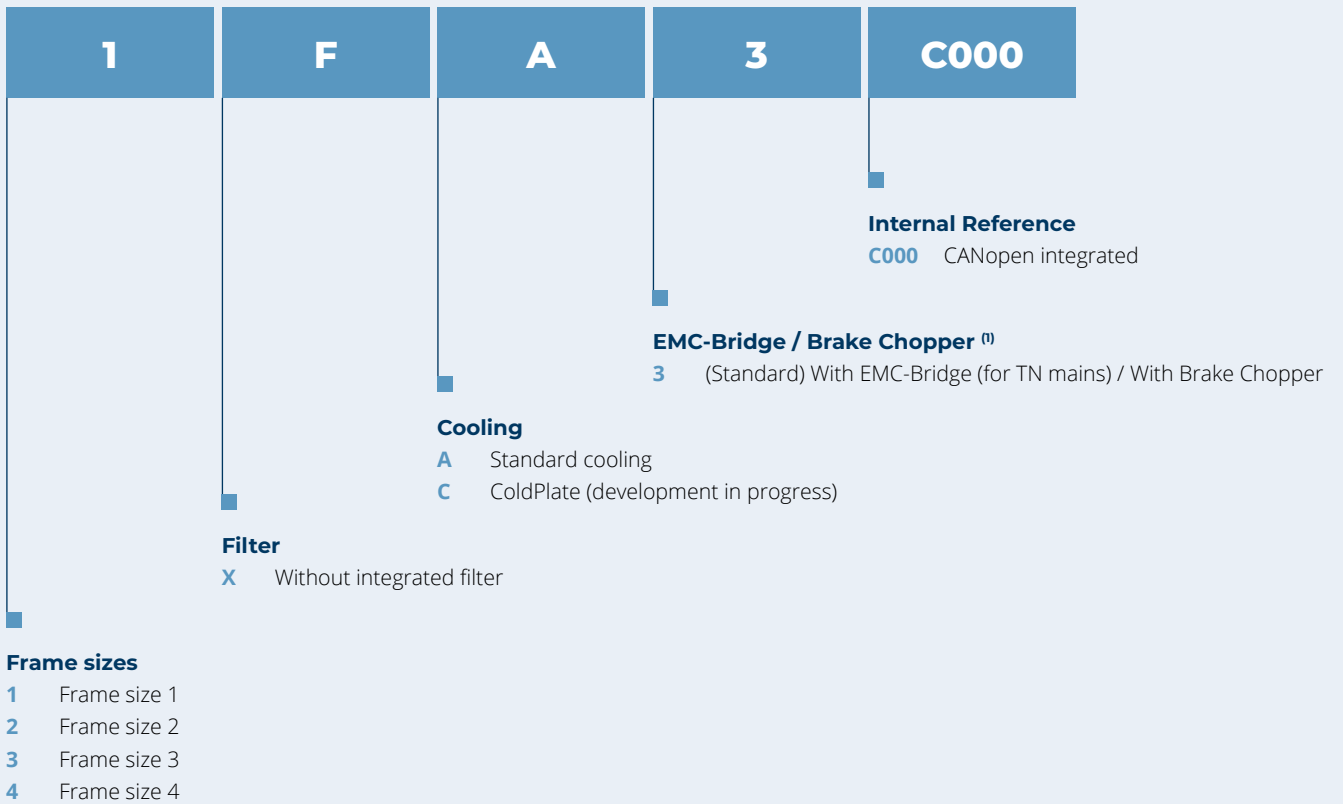

(1) Frame sizes 1...4 have an accessible jumper, which can be used to change from TN mains to IT mains operation.

MODULAR SYSTEM (OPTIONS OVERVIEW)

Great modularity to allow high flexibility for a wide range of applications.

Thanks to its modular structure, the system can be flexibly adapted to meet many different application requirements by selecting among the suitable hardware modules, variants and accessories:

- **Different frame sizes** and **electrical power sizes** for different mains voltages
- **Different mounting variants** and options allow optimum mechanical designs for the electrical cabinet and cooling concepts (Wall mounting with Air Cooling, Feed-Through mounting, ColdPlate and Vibration resilient mounting kit for Air Cooling devices)
- **Different Functional Safety variants** (Basic, Standard or Motion) allow price-fitting and performance-fitting selections
- **Variant with integrated PLC** for freely programmable application adjustments
- **Optional Keypad* Module** with USB-C compatible connector for PC connection
- **Optional Bluetooth* Module** for connection to PC or mobile phone
- **Optional Fieldbus Communication module**
- **Optional First Encoder module**
- **Optional Second Encoder module**
- **Accessories** to select from, such as: mains chokes, filters, brake resistors
- **Optional Cable sets** for connection to BMD motors

(*) Keypad and Bluetooth Module cannot be used at the same time

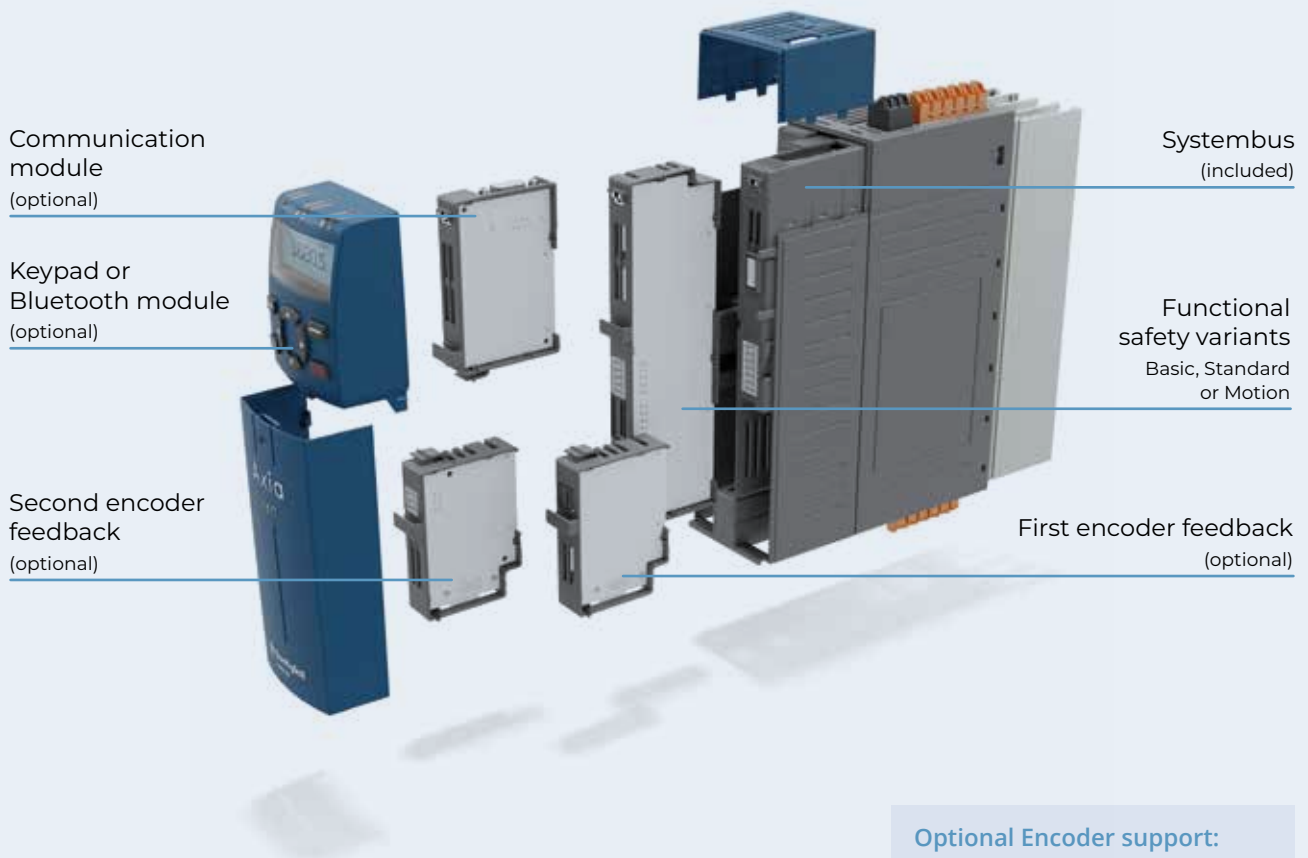

Optional Encoder support:

TTL, Resolver, SinCos, Hiperface, Hiperface DSL, EnDat 2.1, EnDat 2.2, SSI

AXIAVERT SPECIFICATIONS (FEATURES ALWAYS ONBOARD)

The following specifications are always included for each size and power range

MECHANICAL & ELECTRICAL

- **Compact** book-shape **design** for easy integration in electrical cabinets
- **Plug-in control terminals** for easy and fast connection
- **Plug-in power terminals** in frame sizes 1 to 4
- **DC link bus** for “energy sharing” in multidrive system architectures
- Integrated **brake transistor** for **brake resistor connection** on all sizes by default

AUTOMATION

- **Freely programmable** and pre-setup I/Os
- **HTL encoder evaluation** via I/Os
- Freely programmable **Relay output**
- Dedicated **Brake Control** connector
- **External DC 24V supply input** for control board supply from backup systems with easy daisy-chaining connector
- **Deactivation** and **Reactivation of internal EMC** filters (for example for operations in IT mains) with a jumper bridge
- Proprietary **Systembus** for easy integration of electronic gear applications

MOTOR CONTROL

- Vector Control of **asynchronous** motors, **synchronous** motors and **synchronous reluctance** motors (all with or without encoder feedback)
- V/f Control of **asynchronous** motors
- **Preset values** for Bonfiglioli motors to reduce commissioning times
- **Auto-tuning** for advanced motor parameters
- **Auto-tuning** for angle determination (Resolver or absolute encoder) for Synchronous motors
- **Motor thermal evaluation**

MODULARITY

- Up to **2 optional encoder modules** for speed & positioning control
- Optional **Fieldbus communication** (EtherCAT, PROFINET, Ethernet/IP and other)
- Optional **Keypad** or **Bluetooth module**

APPLICATION CONTROL

- **Motor chopper** function to increase braking power without brake resistors
- **4 independent data sets**
- **Flying restart**
- **Spindle control** with tool change positioning
- **Electronic gear** with optional phasing
- **PID control** for example for process controlling
- **Intelligent current limits**
- **Configurable power failure management** for controlled ramping down

MOTION CONTROL INTERFACE

- **Configurable high speed control loops** for position control and speed control
- **Motion control interface** with **CiA402** support for easy integration with external PLC including CSP mode
- **S-ramps** selection with separate adjustable acceleration/deceleration and jerk limitation

MONITORING & DIAGNOSIS

- Up to **6 LEDs** for signaling **device status**, fieldbus status and Functional Safety status
- Adjustable **motor protection** functions
- **Overload protection** and **automatic best switching frequency** adjustment
- **Phase monitoring** (motor and mains)
- **Encoder monitoring**
- **Mean and peak values storage**
- **Fault register** (application and device)

USER INTERFACE

- Optional keypad extension , **PC connection** (wireless, USB-C compatible or Ethernet) or **mobile App** (wireless)
- **User management** (different access levels for parameterization)

SECURE COMMUNICATION

- **Secure Communication** by design with TLS encryption and Authentication management for user interactions via local, remote and IIoT connectivity



AXIAVERT FUNCTIONAL SAFETY

DIFFERENT INTEGRATED FUNCTIONAL SAFETY VARIANTS TO SUIT EVERY APPLICATIONS' REQUIREMENTS

The AxiaVert series offers integrated Functional Safety according to SIL 3 (EN 61508) and PL e (EN 13849-1), organized into **different variants**, which can be selected to best suit the application requirements, **optimizing price and performance** to match the machine functions.

AXIAVERT FUNCTIONAL SAFETY VARIANTS

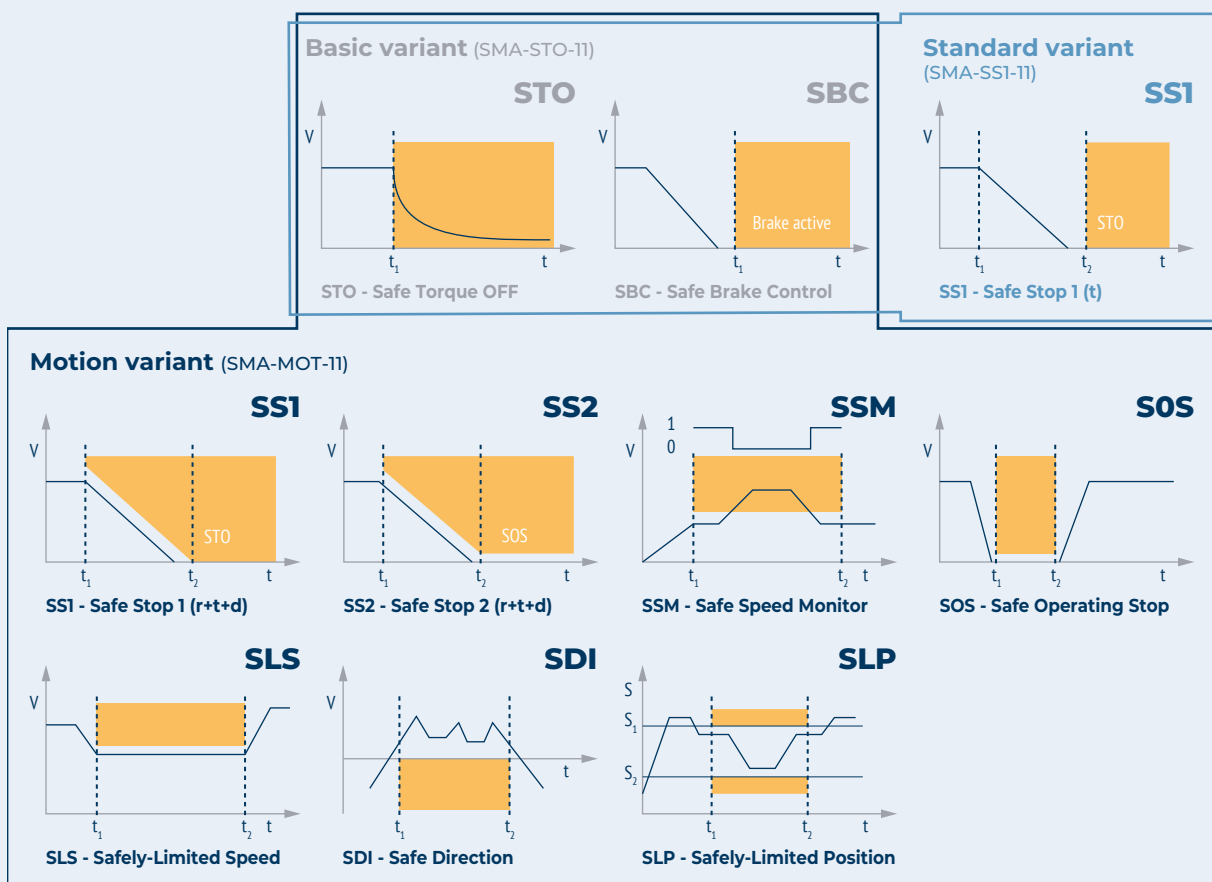

The **Basic variant** (SMA-STO-11) includes Safe Torque Off (STO) and Safe Brake Control (SBC), while the **Standard variant** (SMA-SS1-11) introduces also SS1-t (Safe Stop 1 with time monitoring) reducing the necessity for an external Functional Safety switch.

The **Motion variant** (SMA-MOT-11) adds optional advanced Functional Safety features typically required in motion applications according to ISO13849-1 PLe/Cat.4 and IEC61508 SIL3, product standard 61800-5-2.

Among these, the functions connected with speed SLS, SLS-SL and SSM are available both in sensorless and in closed loop, with the possibility to dynamically set several different safe speed thresholds directly via safety fieldbus. These additional sensorless speed supervision features comply with SIL 2 (EN 61508) and PL d (EN 13849-1). The closed-loop safety functionalities are made available with Hiperface DSL safety encoder.

The FSoE (Fail Safe over EtherCAT) included in the Motion variant, allows, in combination with the EtherCAT communication module, easy integration into Functional Safety communication environments.

The AxiaVert series also offers cost-effective product configurations without any Functional Safety features.



AXIAVERT FUNCTIONAL SAFETY VARIANTS: SUPPORTED FUNCTIONS

Integrated Functional Safety function	Safety level	Basic (SMA-STO-11)	Standard (SMA-SS1-11)	Motion (SMA-MOT-11) ¹⁾	Motion (SMA-MOT-11) & EMA-SABS-xx ²⁾
STO - Safe Torque Off	SIL 3 / PL e / Cat 4	•	•	•	•
SBC - Safe Brake Control	SIL 3 / PL e / Cat 4	•	•	•	•
SS1 - Safe Stop 1 (t)	SIL 2 / PL d / Cat 2		•		
SS1 - Safe Stop 1 (t)	SIL 3 / PL e / Cat 4			•	•
SS1 - Safe Stop 1 (r+ d)	SIL 3 / PL e / Cat 4				•
SS1 - Safe Stop 1 (r+d) (sensorless)	SIL 2 / PL d / Cat 3			•	
SS2 - Safe Stop 2 (r+t+d)	SIL 3 / PL e / Cat 4				•
SOS - Safe Operating Stop	SIL 3 / PL e / Cat 4				•
SLS - Safely Limited Speed	SIL 3 / PL e / Cat 4				•
SLS - Safely Limited Speed (sensorless)	SIL 2 / PL d / Cat 3			•	
SLS-SL - Safely Limited Speed-Sliding Limit	SIL 3 / PL e / Cat 4				•
SLS-SL - Safely Limited Speed-Sliding Limit (sensorless)	SIL 2 / PL d / Cat 3			•	
SDI - Safe Direction	SIL 3 / PL e / Cat 4				•
SSM - Safe Speed Monitor	SIL 3 / PL e / Cat 4				•
SSM - Safe Speed Monitor (sensorless)	SIL 2 / PL d / Cat 3			•	
SLP - Safely Limited Position	SIL 3 / PL e / Cat 4				•
FSoE - Functional Safety over Ethercat				•	•

1) Applies if the combination of encoder and encoder evaluation is not considered to be functionally safe.

2) Hiperface DSL: EMA-SABS-11 module (mounted in expansion slot X412) in combination with fitting Hiperface DSL functional safety encoders.

Note: All speed and Position related functions require a motor encoder with a fitting Functional Safety level for the application. Encoders with lower Functional Safety level or without any Functional Safety level will typically result in a lower overall Functional Safety level.

AXIAVERT CONNECTIVITY

COMMUNICATION AND INDUSTRY 4.0 READINESS

The advanced digital and open communication protocols complying with automation and Industry 4.0 standards allow a **smooth integration into automation networks** thanks to the compatibility with a **wide range of fieldbus protocols** and the possibility to extend the AxiaVert series with the OPC-UA protocol.

Communication encryption is embedded by design in the AxiaVert to ensure **secure communication**.

Thanks to the embedded resources and communication capabilities, it is possible to gather and elaborate data regarding **the device status and energy monitoring** which are subsequently processed through **statistical analysis** for real-time **diagnostics**, alarm management, **predictive maintenance** on the motion chain components and at machine level, allowing to reduce maintenance costs, machine failures and downtime and to increase the safety, efficiency and productivity and improve the spare part handling and the service friendliness.

COMMISSIONING AND MONITORING MADE EASY

The AxiaVert series offers **different options for tuning and diagnostic**:

- a **mobile App**, available for iOS and Android with Bluetooth connection
- a **keypad** with USB-C compatible connection and MMC to store inverter files that can be exchanged with another AxiaVert inverter or a PC
- a **PC GUI** with cable-bound (USB or Ethernet) or Bluetooth connection

The **OPC-UA protocol** allows the exchange of parameter sets between users and inverters and an easy access to cloud-based information about inverters and applications from anywhere via an online connection, useful also for condition monitoring.

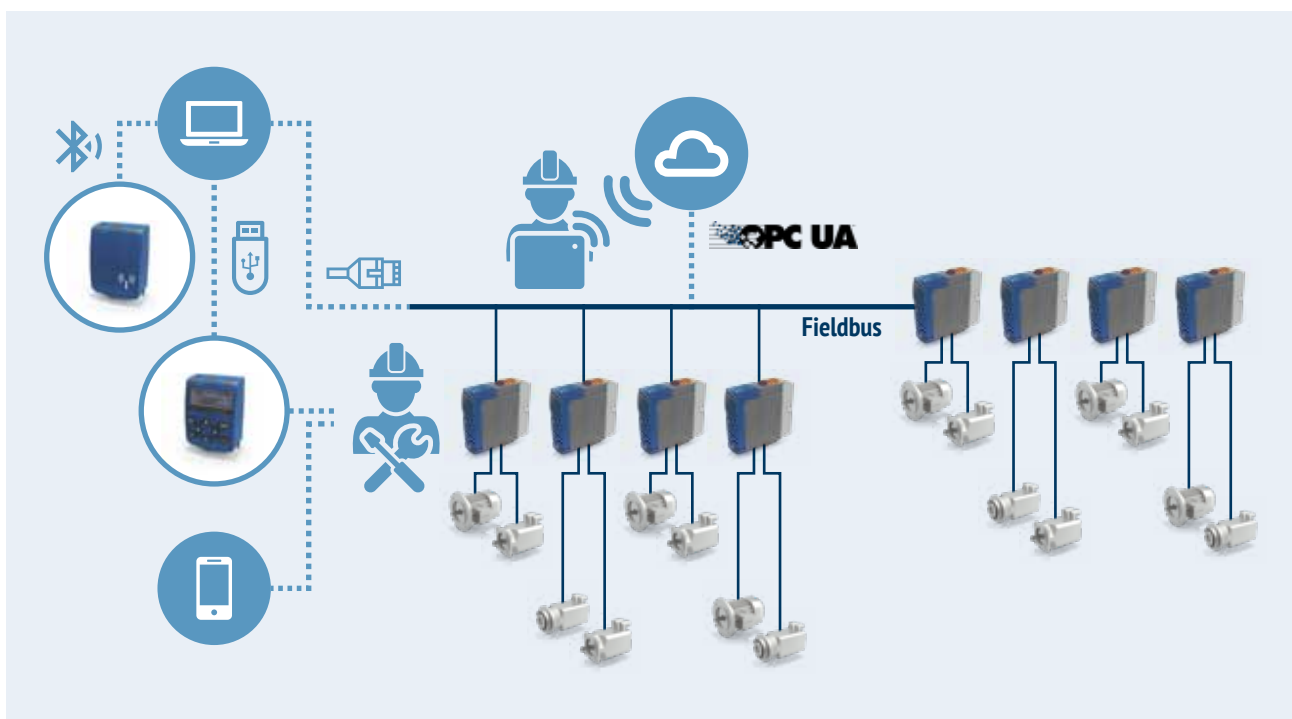

AXIAMANAGER

AxiaManager is the **engineering software** for **the planning, commissioning, operation and monitoring** of the AxiaVert inverters series, providing a range of practical tools to manage the resources of your AxiaVert inverter completely and efficiently.

AxiaManager is available as a **Windows PC GUI** and as a **mobile App** for an instant access to the drive status and configuration with a **simplified user interface**.

Characterized by a **top-level user experience** and available in Simple and Advanced mode, it offers **optimized workflows** for both occasional and professional users, ensuring marked savings in terms of time and costs thanks to **accelerating engineering**. In addition, users can count on the support from a Bonfiglioli expert from commissioning to troubleshooting thanks to the **online remote support** function.

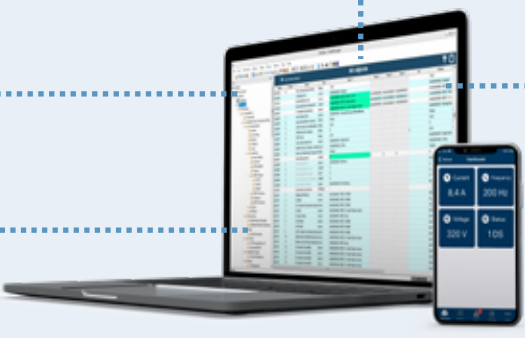

SAVE TIME thanks to the top-level user experience and intuitive navigation for accelerated engineering

GET THE SUPPORT YOU NEED thanks to real-time remote support from a Bonfiglioli expert

INCREASE EFFICIENCY by developing optimized, integrated solutions

REDUCE COMPLEXITY thanks to a unique tool for planning, commissioning, tuning and monitoring your automation projects

AXIAMANAGER FOR PC

AxiaManager is available as a **Windows PC GUI**, where the computer is connected to the inverter through **optional cable** (USB or Ethernet) or **Bluetooth connection**.

PLAN, CONFIGURE AND CONNECT

With AxiaManager for PC it is possible to **commission entire automation systems including multiple inverters** through an **easy guided procedure**, both in **online mode** by choosing the connection interface and its parameters to scan the available inverters, and in **offline mode** by selecting the inverters from the catalogue.

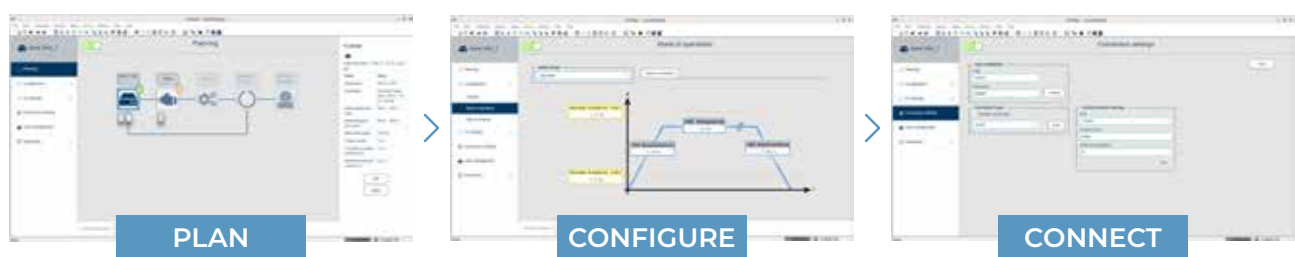

AXIAMANAGER

AXIAMANAGER FOR PC

The **planning section** allows to add, edit and remove components such as:

- Motors
- Gearboxes
- Encoder feedback

The **configuration phase** allows to set both the inverter driving tasks via the control mode (V/f, FOC) and the control source objects (I/O, keypad, etc...), and the inverter mode of operation via interactive graphs.

The **connection settings** page displays prefilled fields, which can optionally be modified in manual mode. By scanning for online inverters, you have an instantaneous field population with actual inverter data values.

TUNING

By switching to the Advanced mode, users can access **the parameter and object view** which allows several functions for a more in-depth analysis and tuning, such as:

- Reading/writing/setting default object values
- Writing only the modified parameters not yet present in the inverter
- Resetting all the default values and objects and to restart the inverter
- Filtering and showing/hiding objects by specific criteria (for example by name, object or description)
- Setting the value of one parameter's dataset in all its other datasets
- Creating recipes with sets of configuration objects for specific applications. These recipes can be saved and later applied to other inverters performing the same operations.



MONITORING

The monitoring functionality in the PC GUI Advanced view is displayed through the **monitor window** and the **graph window**. It is possible to easily drag & drop objects from the tabular view of one or more connected inverters to the related monitoring window and to save the monitored objects in a file for future use.

In the graph window, two different oscilloscope functions are available.

The **free-run oscilloscope** for commissioning and troubleshooting analysis allows collecting **unlimited number of samples** for up to **4 tracks**.

The oscilloscope function is available also in a **real-time** version, offering a high time and trigger resolution and allowing the simultaneous supervision at high frequency sampling of **1,000 samples** for up to **4 variables**, such as commissioning variables, variables to monitor performance levels or to tune the control loops.

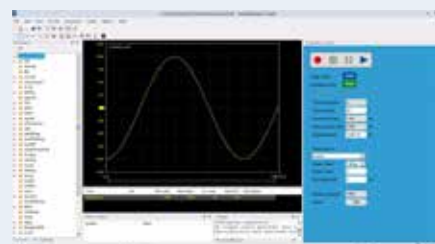

AXIAMANAGER MOBILE APP

The AxiaManager Mobile App provides **easy-to-use parameterization**, **diagnostic dialogs** and an **intuitive graphical user interface**, allowing you to keep the necessary overview of your applications in every situation.

AxiaManager Mobile App for iOS allows connection to the AxiaVert inverters via optional **Bluetooth connection**.

EASY AND FAST ACCESS TO PRODUCT INFORMATION

The AxiaManager Mobile App gives you access to the drive status and configuration with a simplified user guidance. The App displays a list of the main parameters relative to all the devices included in the connected applications. A **user-friendly navigation menu** supports you in all machine adjustments and parameters modifications, allowing a **constant and quick optimization** of your applications.

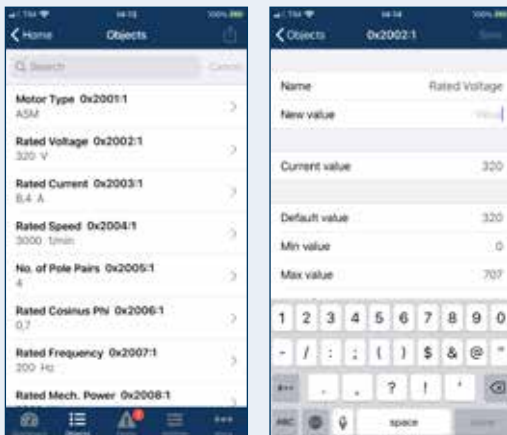

MONITORING AND TROUBLESHOOTING ON THE GO

The App provides **access to your products within the range of the bluetooth connection** in the form of **concise dashboards** for a quick monitoring of the current status of the AxiaVert inverters.



The mobile App displays the **fault history** stored on the connected inverter, showing it in a simple list. From the main list the user can select a particular fault to view the related details or delete all faults.

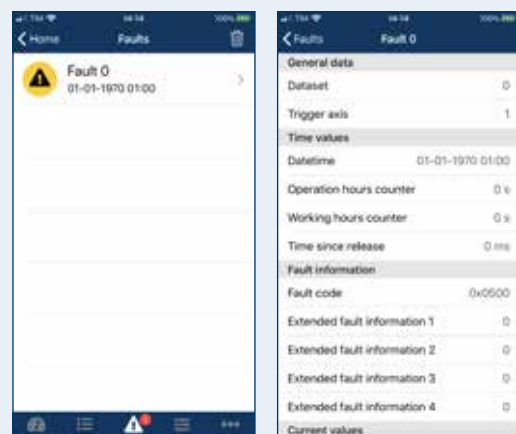

AXIAMANAGER PLC

The standard functions of AxiaVert frequency inverters can be flexibly extended through an **integrated internal PLC**, programmable with a high-end PC software interface to write, compile, download and debug the applications autonomously developed by the user. The AxiaManager PLC allows a **flexible and effective management of automation tasks** characterized by different degrees of complexity through **complete personalization** of the drives and a **user-friendly** and **powerful graphic interface**.

- **IEC61131-3 standard:** AxiaManager PLC supports all the graphical and textual programming languages defined by the IEC 61131-3 standard, including basic data types, structures, arrays and user-defined data types. All the 5 languages (Instruction List, Ladder diagram, Function Block diagram, Sequential Function Chart and Structured Text) according to the IEC 61131-3 standard can be used simultaneously within the same application, so that the most suitable language can be selected for each software module.
- **Top-level user experience:** an intuitive navigation and the drag and drop of parameters directly from the AxiaManager GUI provide a fast and easy design of control sequences.
- **Highest efficiency for the most demanding application:** the generated executable code written according to the IEC 61131-3 standard is translated directly into machine code, thus making the program execution as efficient as possible also for time-critical applications.
- **Development supporting tools:** AxiaManager PLC integrates a series of diagnostic tools supporting the application debugging, its setting and optimization. It allows the display, both numerical and graphical, of all drive and application variables which have been configured through the drag-and drop mode. Through a dedicated window, users can define **triggers** in code locations in order to display the value of selected variables at runtime, without the need of stopping the application. In addition users can insert **breakpoints** and the support for **single-step execution** is also available. AxiaManager PLC supports the **live debug** function, highlighting any programming errors and displaying them in a dedicated window during the compiling process for all the programming languages. The detected error position and cause are displayed with a direct link to the relative program section to be analyzed. The integrated **simulator** allows executing and debugging the whole application on the PC through a digital twin of the system without the need of physical hardware.



COMMUNICATION MODULES

With its high level connectivity, AxiaVert gives users **great freedom in developing communication networks** that are **tailored to their specific requirements**.

The AxiaVert series offers a **wide range of optional communication modules** (see Table), supporting the main, globally established communication protocols, for and **easy and smooth integration into industrial communication networks**, fostering the highest efficiency throughout the entire product life cycle.

The communication modules can easily be mounted as a **plug & work solution**.

Standardized DSUB-9 and RJ45 connectors (depending on the module) are used for the connection with the PLC.

The **CMA-IE-01** is a multi-protocol module in which the protocol can be switched through parameterization.

Fieldbus	Optional module	No. of physical ports
EtherCAT	CMA-IE-01	2
PROFINET	CMA-IE-01	2
POWERLINK (in preparation)	CMA-IE-01	2
Ethernet/IP	CMA-IE-01	2
Ethernet TCP/IP Modbus/TCP	CMA-ETH-01	2
PROFIBUS	CMA-PB-01	1
CANopen	CMA-CAN-01	1
RS485/Modbus	CMA-485-01	1
RS232/Modbus	CMA-232-01	1



CANopen®

PROFI[®]
BUS

EtherCAT[®]

PROFI[®]
NET

ETHERNET
POWERLINK

KEYPAD AND USB CONNECTIONS



The keypads **KPA-DSP-01** and **KPA-DSP-11** are universal tools in the daily operation of the AxiaVert device. A **graphical backlit LCD display** with 4 lines of text display makes the work with the AxiaVert series quick and efficient.

The functions are:

- Access to all relevant device objects for **diagnosis and setup**
- **Fault analysis** with dedicated Fault lists
- **Guided Motor setup, Communication Setup** and **Application Setup**
- **Copy Function** to store and load the device object settings to a file on the module (KPA-DSP-01)
- **MMC slot for memory extensions** for language support and parameter storage (KPA-DSP-01)

The integrated **USB-C compatible connector** enables the communication with a PC (KPA-DSP-01).

BLUETOOTH/WIRELESS MODULE



The Remote Access Module **REA-WL-01** allows a very user-friendly **connection to a PC or a mobile phone via Bluetooth**.

The connection of Bluetooth using the PC and AxiaManager Software offers the same functionality as a USB connection.

Also the **REA-WL-01** extends the functionality of Bluetooth to **connect with the AxiaManager Mobile App** dedicated for iOS and Android smartphones.

ENCODER MODULES



The Encoder modules **EMA** can extend the device with **encoder evaluation**. One or **two encoder modules can be integrated** optionally into the AxiaVert device. This allows, for example, the evaluation of the same encoder or different encoders for Speed control & Position control.

SYSTEM DESCRIPTION GRAPHIC

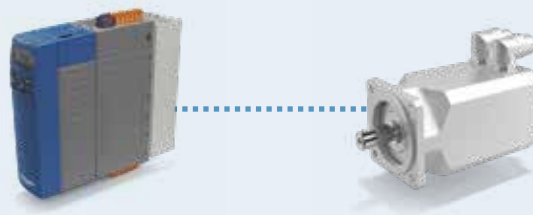

Module name	Supported Encoders
EMA-ABS-01	TTL, SinCos, Hiperface, SSI, EnDat 2.1 with SinCos tracks
EMA-ENC-01	TTL
EMA-RES-01	Resolver
EMA-SABS-11*	Hiperface DSL (fully digital with functional safety*)
EMA-ABS-21	EnDat 2.2 (without SinCos tracks, fully digital)

THE FOLLOWING COMBINATIONS FOR ENCODER MODULES ARE AVAILABLE.

Module name	Encoder Slot X412*	Encoder Slot X432*
EMA-ABS-01	•	•
EMA-ENC-01	•	•
EMA-SABS-11*	•	•
EMA-ABS-21	•	•
EMA-RES-01	•	

Note:

* EMA-SABS-11 supports Functional Safety features when mounted in slot X412 and when SMA-MOT-11 is present. When mounted in slot X432, the module EMA-SABS-11 does not support Functional Safety features.



ENCODER MODULES

ENCODER AND PTC INPUT X412 (FEMALE CONNECTOR HD-DSUB-15 OR DSUB-9)

Contact	EMA-ABS-01					
	Sin/Cos	TTL	Hiperface	EnDat 2.1 with SinCos tracks	SSI	
Housing	PE		PE	PE	PE	
1	D-			Clock-	Clock-	
2	D+			Clock+	Clock+	
3	Cos-	B-	Cos-	B- / Cos-	(optionally B- / Cos-)	
4	Cos+	B+	Cos+	B+ / Cos+	(optionally B+ / Cos+)	
5	TM _{PTC} -	TM _{PTC} -	TM _{PTC} -	TM _{PTC} -	TM _{PTC} -	
6	V _{Enc}	V _{Enc}	V _{Enc}	V _{Enc}	V _{Enc}	
7	R-	R-				
8	C-		Data-	Data-	Data-	
9	Sin-	A-	Sin-	A- / Sin-	(optionally A- / Sin-)	
10	TM _{PTC} +	TM _{PTC} +	TM _{PTC} +	TM _{PTC} +	TM _{PTC} +	
11	V _{Enc, Sense}	V _{Enc, Sense}		V _{Enc, Sense}	V _{Enc, Sense}	
12	R+	R+				
13	C+		Data+	Data+	Data+	
14	Sin+	A+	Sin+	A+ / Sin+	(optionally A+ / Sin+)	
15	GND	GND	GND	GND	GND	

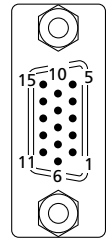

Contact	EMA-ENC-01	EMA-SABS-11	EMA-SABS-21
	TTL	Hiperface DSL	EnDat 2.2 without SinCos tracks
Housing	PE	PE	PE
1			Clock-
2			Clock+
3	B-		
4	B+		
5	TM _{PTC} -		
6	V _{Enc}		V _{Enc}
7	R-		
8			Data-
9	A-	Data P-	
10	TM _{PTC} +		TM _{PTC}
11	V _{Enc, Sense}		V _{Enc, Sense}
12	R+		
13			Data+
14	A+	Data P+	
15	GND		GND

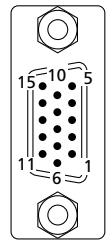

Contact	EMA-RES-01
Housing	PE
1	PE
2	TM _{PTC} +
3	Cos+
4	Sin+
5	Excitation+
6	TM _{PTC} -
7	Cos-
8	Sin-
9	Excitation-

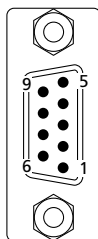

GENERAL TECHNICAL DATA

ENVIRONMENT

Operating conditions

- 0 ... 55°C (50 ... 55°C with derating)
- Pollution Degree 2
- Environment class during operation 3K3 (EN60721-3-3)
- Relative humidity 5% ... 95%, no condensation
- Overvoltage Category III for mains connection
- Overvoltage Category III for relay connector circuit up to 2000 m
- Overvoltage Category II for relay connector circuit above 2000 m

Altitude of installation

- Up to 1000m (up to 4000m with derating)

Protection degree (EN 60529)

- IP20 with correctly mounted covers and connection terminals
- Environmental operation conditions according to DIN EN 60721-3-3:
 - 3Z1 (negligible thermal radiation)
 - 3B1 (no biological impact)
 - 3C1 (chemically active substances, limits as per standard)
 - 3S1 (mechanically active substances, no sand in air, limits as per standard)
 - 3M4 (mechanical vibration and shocks, limits as per standard)

Storage conditions

- According to EN50178

Robustness

- Coated boards to enhance the device resilience
- Vibration robustness according to DIN EN 60068-2-6: Test Fc and DIN EN 60068-2-27: Test Ea

Interference immunity

- According to EN 61800-3 for use in industrial environments

ELECTRICAL

MAINS VOLTAGE OPERATION

- AXV20 in the range AC 1~/3~ 184-0% ... 240 V+10%
- AXV40 in the range AC 3~ 380-15% ... 480 V+10%

Rated mains frequency

- 45 ... 66 Hz

Overload current / Peak current

- 150% Rated current for 60 s
- 200% Rated current for 3 s

Electric protection

- Short-circuit / Earth fault proof

Braking transistor

- Built-in by default

CONFORMITY AND CERTIFICATES

CE conformity:

- 2014/35/EU (Low voltage directive)
- 2014/30/EU (Electromagnetic Compatibility Directive)
- 2011/65/EU + 2015/863/EU (RoHS Directive)
- 2009/125/EC (Ecodesign Directive) & 2019/1781/EU (Ecodesign implementation commission regulation)

UL/CSA approval:

- UL61800-5-1/CSA 22.2-No 274

FUNCTIONAL SAFETY

- EN61800-5-2 (Adjustable speed electrical power drive systems - Safety requirements - Functional)

AXV20 | TECHNICAL DATA (FROM 0.25 TO 3.0 KW)

AXV20xx	k25	k37	k55	k75	1k1	1k5	2k2	3k0	
	Size 1 (FA, FC, XA or XC)					Size 2 (FA, FC, XA or XC)			

Output, motor side⁽¹⁾

Recommended rated motor power	P_n	kW	0.25	0.37	0.55	0.75	1.1	1.5	2.2	3.0
Rated current output	I_n	A	1.6	2.5	3.0	4.0	5.4	7.0	9.5	12.5
Rated voltage output	U_n	V	3 x (from 0 to mains voltage)							
Overload current (60 s)	I_{OL}	A	2.4	3.75	4.5	6.0	8.1	10.5	14.25	18.75
Peak current (3 s)	I_{pk}	A	3.2	5.0	6.0	8.0	10.8	14.0	19.0	25.0
Switching Frequency	f_c	kHz	2, 4, 8 ⁽¹⁾ & 16 ⁽¹⁾ kHz							
Output frequency	f_n	Hz	0...599 Hz (0...2000 Hz for Spindle variants)							

Input, mains side

Rated mains voltage	U	V	230							
Working voltage range	U	V	184...240 + 10 %							
Rated current 3 ph, IEC	I	A	1.1	1.4	2.0	2.6	3.8	5.2	7.4	10.0
Rated current 1 ph/N; 2 ph IEC	I	A	2.4	3.1	4.4	5.8	8.4	11.4	16.1	21.9

Terminals

Connection Signal terminals ⁽¹⁾	A	mm ²	0.25 ... 1.5 (detachable terminals)							
Connection Power terminals ⁽¹⁾	A	mm ²	0.5 ... 2.5 (detachable terminals)							

General

Short circuit/ground fault protection	-	-	Measures against overload and short-circuit integrated in the device								
Mounting position	-	-	Vertical								
Dimensions Standard Device	HxWxD	mm	200 x 60 x 231					250 x 60 x 231			
Dimensions ColdPlate Device	HxWxD	mm	200 x 60 x 193					250 x 60 x 193			
Weight (approx.)	m	kg	1.4					1.8			
Brake chopper	-	-	Internal brake chopper								
UL/CSA approval	-	-	UL61800-5-1 and CSA 22.2-No 274								

Environment

Cooling temperature	T_n	°C	Nominal values from 0 to 50°C / up to 55°C with derating							
Relative air humidity	-	%	From 5 to 95, non-condensing							

Options & accessories

Screen sheet for cable screens	-	-	SCA-SIGT-01 / SCA-SIGB-01 / SCA-PWR1&2-01								
Feed through mounting kit	-	-	MKA-FT1-01					MKA-FT2-01			
Input line choke ⁽²⁾	-	-	External (depending on mains supply)								
EMI filter ⁽²⁾	-	-	For selection of EMI related components, please check the Input filter table in this catalogue								

Notes:

(1) Check the technical data document for additional data

(2) For more details, please check the Input filter table/EMI table in this catalogue

AXV20 | TECHNICAL DATA (FROM 4.0 TO 9.2 KW)

AXV20xx		4k0	5k5	7k5	9k2
		Size 3 (FA, FC, XA or XC)		Size 4 (A or C)	
Output, motor side⁽¹⁾					
Recommended rated motor power	P _n kW	4.0	5.5	7.5	9.2
Rated current output	I _n A	18.0	22.0	32.0	35.0
Rated voltage output	U _n V	3 x (from 0 to mains voltage)			
Overload current (60 s)	I _{OL} A	27.0	33.0	48.0	52.5
Peak current (3 s)	I _{pk} A	36.0	44.0	53.0	70.0
Switching Frequency	f _c kHz	2, 4, 8 ⁽¹⁾ & 16 ⁽¹⁾ kHz			
Output frequency	f _n Hz	0...599 Hz (0...2000 Hz for Spindle variants)			
Input, mains side					
Rated mains voltage	U V	230			
Working voltage range	U V	184...240 + 10 %			
Rated current 3 ph, IEC	I A	13.3	17.8	23.9	29.0
Terminals					
Connection Signal terminals ⁽¹⁾	A mm ²	0.25 ... 1.5 (detachable terminals)			
Connection Power terminals ⁽¹⁾	A mm ²	0.5 ... 10 (detachable terminals)		0.5 ... 16 (detachable terminals)	
General					
Short circuit/ground fault protection	- -	Measures against overload and short-circuit integrated in the device			
Mounting position	- -	Vertical			
Dimensions Standard Device	HxWxD mm	250 x 80 x 245		250 x 125 x 249	
Dimensions ColdPlate Device	HxWxD mm	250 x 80 x 194		250 x 125 x 194	
Weight (approx.)	m kg	2.7		4.0	
Brake chopper	- -	Internal brake chopper			
UL/CSA approval	- -	UL61800-5-1 and CSA 22.2-No 274			
Environment					
Cooling temperature	T _n °C	Nominal values from 0 to 50°C / up to 55°C with derating			
Relative air humidity	- %	From 5 to 95, non-condensing			
Options & accessories					
Screen sheet for cable screens	- -	SCA-SIGT-01 / SCA-SIGB-01 / SCA-PWR3-01		SCA-SIGT-01 / SCA-SIGB-01 / SCA-PWR4-01	
Feed through mounting kit	- -	MKA-FT3-01		MKA-FT4-01	
Input line choke ⁽²⁾	- -	External (depending on mains supply)			
EMI filter ⁽²⁾	- -	For selection of EMI related components, please check the Input filter table in this catalogue			

Notes:

(1) Check the technical data document for additional data

(2) For more details, please check the Input filter table/EMI table in this catalogue



AXV40 | TECHNICAL DATA (FROM 0.25 TO 1.5 KW)

AXV40xx		k25	k37	k55	k75	1k1	1k5	
Size 1 (FA, FC, XA or XC)								
Output, motor side⁽¹⁾								
Recommended rated motor power	P _n	kW	0.25	0.37	0.55	0.75	1.1	1.5
	P _n	HP	0.33	0.5	0.75	1.0	1.5	2.2
Rated current output, 400 V	I _n	A	1.0	1.6	1.9	2.4	3.2	4.2
Rated current output, 480 V	I _n	A	0.8	1.3	1.5	2.0	2.6	3.5
Rated voltage output	U _n	V	3 x (from 0 to mains voltage)					
Overload current (60 s), 400 V	I _{OL}	A	1.5	2.4	2.85	3.6	4.8	6.3
Peak current (3 s), 400 V	I _{pk}	A	2.0	3.2	3.8	4.8	6.4	8.4
Switching Frequency	f _c	kHz	2, 4, 8 ⁽¹⁾ & 16 ⁽¹⁾ kHz					
Output frequency	f _n	Hz	0...599 Hz (0...2000 Hz for Spindle variants)					
Input, mains side								
Rated mains voltage	U	V	400					
Working voltage range	U	V	380-15 % ... 480 + 10 %					
Rated current 3 ph, 400 V	I	A	0.6	0.8	1.2	1.5	2.2	3.0
Rated current 3 ph, 480 V	I	A	0.5	0.7	1.0	1.3	1.8	2.5
Terminals								
Connection Signal terminals ⁽¹⁾	A	mm ²	0.25 ... 1.5 (detachable terminals)					
Connection Power terminals ⁽¹⁾	A	mm ²	0.5 ... 2.5 (detachable terminals)					
General								
Short circuit/ground fault protection	-	-	Measures against overload and short-circuit integrated in the device					
Mounting position	-	-	Vertical					
Dimensions Standard Device	HxWxD	mm	200 x 60 x 231					
Dimensions ColdPlate Device	HxWxD	mm	200 x 60 x 193					
Weight (approx.)	m	kg	1.4					
Brake chopper	-	-	Internal brake chopper					
UL/CSA approval	-	-	UL61800-5-1 and CSA 22.2-No 274					
Environment								
Cooling temperature	T _n	°C	Nominal values from 0 to 50°C / up to 55°C with derating					
Relative air humidity	-	%	From 5 to 95, non-condensing					
Options & accessories								
Screen sheet for cable screens	-	-	SCA-SIGT-01 / SCA-SIGB-01 / SCA-PWR1&2-01					
Feed through mounting kit	-	-	MKA-FT1-01					
Input line choke ⁽²⁾	-	-	External (depending on mains supply)					
EMI filter ⁽²⁾	-	-	For selection of EMI related components, please check the Input filter table in this catalogue					

Notes:

(1) Check the technical data document for additional data

(2) For more details, please check the Input filter table/EMI table in this catalogue



AXV40 | TECHNICAL DATA (FROM 1.85 TO 4.0 KW)

AXV40xx		1k9	2k2	3k0	4k0
Size 2 (FA, FC, XA or XC)					
Output, motor side⁽¹⁾					
Recommended rated motor power	P _n kW	1.85	2.2	3.0	4.0
	P _n HP	2.5	3.0	4.0	5.0
Rated current output, 400 V	I _n A	5.1	5.8	7.8	9.5
Rated current output, 480 V	I _n A	4.2	4.8	6.5	7.9
Rated voltage output	U _n V	3 x (from 0 to mains voltage)			
Overload current (60 s), 400 V	I _{OL} A	7.65	8.4	11.7	14.25
Peak current (3 s), 400 V	I _{pk} A	10.2	11.6	15.6	19.0
Switching Frequency	f _c kHz	2, 4, 8 ⁽¹⁾ & 16 ⁽¹⁾ kHz			
Output frequency	f _n Hz	0...599 Hz (0...2000 Hz for Spindle variants)			
Input, mains side					
Rated mains voltage	U V	400			
Working voltage range	U V	380-15 % ... 480 + 10 %			
Rated current 3 ph, 400 V	I A	3.7	4.3	5.8	7.6
Rated current 3 ph, 480 V	I A	3.1	3.5	4.8	6.4
Terminals					
Connection Signal terminals ⁽¹⁾	A mm ²	0.25 ... 1.5 (detachable terminals)			
Connection Power terminals ⁽¹⁾	A mm ²	0.5 ... 2.5 (detachable terminals)			
General					
Short circuit/ground fault protection	- -	Measures against overload and short-circuit integrated in the device			
Mounting position	- -	Vertical			
Dimensions Standard Device	HxWxD mm	250 x 60 x 231			
Dimensions ColdPlate Device	HxWxD mm	250 x 60 x 193			
Weight (approx.)	m kg	1.8			
Brake chopper	- -	Internal brake chopper			
UL/CSA approval	- -	UL61800-5-1 and CSA 22.2-No 274			
Environment					
Cooling temperature	T _n °C	Nominal values from 0 to 50°C / up to 55°C with derating			
Relative air humidity	- %	From 5 to 95, non-condensing			
Options & accessories					
Screen sheet for cable screens	- -	SCA-SIGT-01 / SCA-SIGB-01 / SCA-PWR1&2-01			
Feed through mounting kit	- -	MKA-FT1-01			
Input line choke ⁽²⁾	- -	External (depending on mains supply)			
EMI filter ⁽²⁾	- -	For selection of EMI related components, please check the Input filter table in this catalogue			

Notes:

(1) Check the technical data document for additional data

(2) For more details, please check the Input filter table/EMI table in this catalogue



AXV40 | TECHNICAL DATA (FROM 5.5 TO 15.0 KW)

AXV40xx		5k5	7k5	9k2	11k	15k
		Size 3 (FA, FC, XA or XC)			Size 4 (A or C)	
Output, motor side⁽¹⁾						
Recommended rated motor power	P _n kW	5.5	7.5	9.2	11.0	15.0
	P _n HP	7.5	10.0	12.5	15.0	20.0
Rated current output, 400 V	I _n A	14.0	19.0	23.0	25.5	32.5
Rated current output, 480 V	I _n A	11.6	15.8	19.1	21.2	27.0
Rated voltage output	U _n V	3 x (from 0 to mains voltage)				
Overload current (60 s), 400 V	I _{OL} A	21.0	28.5	34.5	38.25	48.75
Peak current (3 s), 400 V	I _{pk} A	28.0	38.0	46.0	51.0	65.0
Switching Frequency	f _c kHz	2, 4, 8 ⁽¹⁾ & 16 ⁽¹⁾ kHz				
Output frequency	f _n Hz	0...599 Hz (0...2000 Hz for Spindle variants)				
Input, mains side						
Rated mains voltage	U V	380-15 % ... 480 + 10 %				
Rated current 3 ph, 400 V	I A	10.3	13.8	16.6	19.6	26.8
Rated current 3 ph, 480 V	I A	8.6	11.5	13.8	16.4	22.3
Terminals						
Connection Signal terminals ⁽¹⁾	A mm ²	0.25 ... 1.5 (detachable terminals)				
Connection Power terminals ⁽¹⁾	A mm ²	0.5 ... 10 (detachable terminals)			0.5 ... 16 (detachable terminals)	
General						
Short circuit/ground fault protection	- -	Measures against overload and short-circuit integrated in the device				
Mounting position	- -	Vertical				
Dimensions Standard Device	HxWxD mm	250 x 80 x 245			250 x 125 x 249	
Dimensions ColdPlate Device	HxWxD mm	250 x 80 x 194			250 x 125 x 194	
Weight (approx.)	m kg	2.7			4.0	
Brake chopper	- -	Internal brake chopper				
UL/CSA approval	- -	UL61800-5-1 and CSA 22.2-No 274				
Environment						
Cooling temperature	T _n °C	Nominal values from 0 to 50°C / up to 55°C with derating				
Relative air humidity	- %	From 5 to 95, non-condensing				
Options & accessories						
Screen sheet for cable screens	- -	SCA-SIGT-01 / SCA-SIGB-01 / SCA-PWR3-01			SCA-SIGT-01 / SCA-SIGB-01 / SCA-PWR4-01	
Feed through mounting kit	- -	MKA-FT3-01			MKA-FT4-01	
Input line choke ⁽²⁾	- -	External (depending on mains supply)				
EMI filter ⁽²⁾	- -	For selection of EMI related components, please check the Input filter table in this catalogue				

Notes:

(1) Check the technical data document for additional data

(2) For more details, please check the Input filter table/EMI table in this catalogue

CONTROL TERMINALS

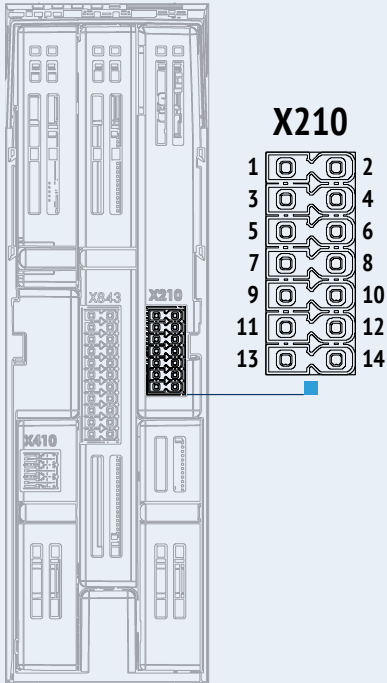

X210

1	DC 24 V Out	2	GND
3	IN1D: Digital Input 1	4	IN4D: Digital Input 4
5	IN2D: Digital Input 2	6	IN5D: Digital Input 5
7	IN3D: Digital Input 3	8	IN6D/OUT6D: Digital Input 6/Digital Output 6
9	MFI2: Analog Multifunction 2 Input (0...+10V, -10...+10V, 0...20 mA, KTY, PT1000, PTC)	10	GND (digital)
11	OUT1A: Analog Output (0... +10V)	12	GND (analog)
13	MFI1A: Multifunction Input1 (0...10 V, 0/4...20 mA)	14	GND (analog)

The digital inputs IN1D...IN5D can be switched to either PNP or NPN logic.
The digital inputs can also be used for the evaluation of an HTL encoder.

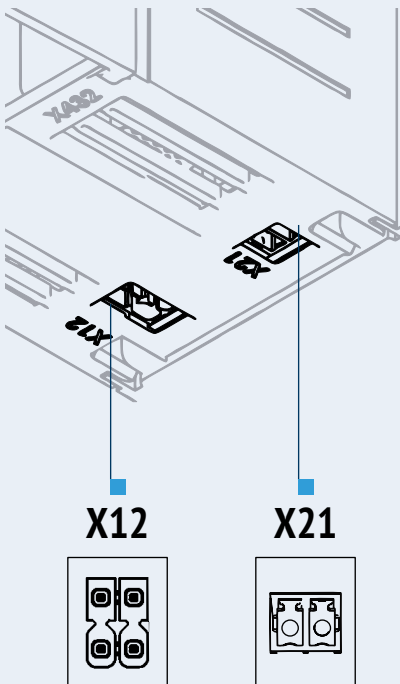

Brake connection output*

2 X 1 PINS TERMINAL [X21]

Left column	Right column	Description
Brake +	Brake -	Brake contact output (DC 24 V / 3A transistor output)

* For Functional Safety variants of AxiaVert the Brake Control output can be used as Safe Brake Control (SBC).

DC 24 V Supply IO

2 X 2 PINS TERMINAL [X12]

Left column	Right column	Description
DC 24 V In	GND	DC 24 V Input / GND
DC 24 V In	GND	DC 24 V Input / GND

FUNCTIONAL SAFETY TERMINALS

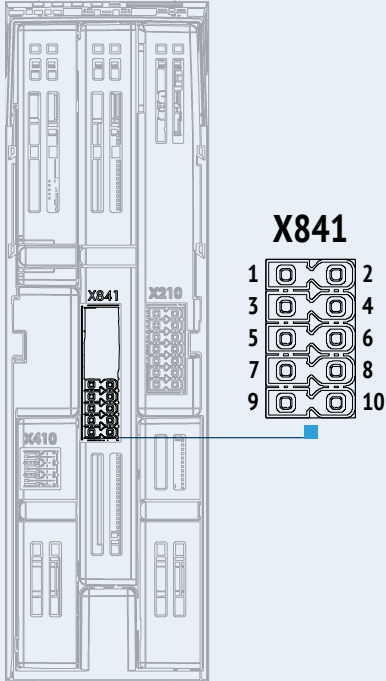

AXIAVERT FUNCTIONAL SAFETY TERMINAL

SMA-STO-11

(Basic Functional Safety variant with STO & SBC)

SMA-SS1-11

(Standard Functional Safety variant with STO, SBC & SS1-t)

2 X 5 PINS TERMINAL

Left terminal	Right terminal	Description
STO-A	STO-B	Safe Torque Off
GND	GND	GND
SBC-A	SBC-B	Safety Brake Control Activation
SS1-t	n.c.	Optional SS1-t Input connection (available in module SMA-SS1-11)
OSSD	OSSD	Optional Output Signal Switching Device or Safe DC 24 V output

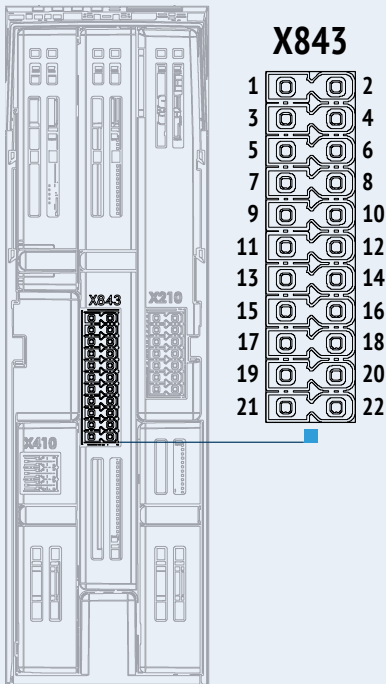

SMA-MOT-11

(Motion Functional Safety variant)

2 X 11 PINS TERMINAL

Left terminal	Right terminal	Description
DI1-A	DI1-B	Digital Input 1 (path A and B), programmable
DI2-A	DI2-B	Digital Input 2 (path A and B), programmable
DI3-A	DI3-B	Digital Input 3 (path A and B), programmable
DI4-A	DI4-B	Digital Input 4 (path A and B), programmable
Acknowledg.	Restart	Error- and Restart Acknowledgement inputs
GND	GND	GND
DO1-A	DO1-B	Digital Output 1 (path A and B), programmable – also programmable as DC 24 V OSSD output
DO2-A	DO2-B	Digital Output 2 (path A and B), programmable – also programmable as DC 24 V OSSD output
GND	GND	GND
Status SBC	n.c.	Diagnostic Status Safe Brake Control
DC 24 V	DC 24 V	DC 24 V Output

MOUNTING OF STANDARD DEVICES

A **wide range of mechanical accessories** is available for AxiaVert series, to make **installation as easy as possible** in all sorts of applications.

In standard mountings, the unit can be **installed directly on the mounting plate or as feed-through unit** with optional mounting equipment.

The range of mounting variants also includes an **optional support with shielded brackets**, so that the right solution for all possible needs can always be found.

TYPES OF MOUNTING KITS MKA

The drive is supplied complete for fixing to an electrical cabinet mounting panel. 3 optional installation kits are additionally available.

MKA-STD (Standard Mounting Kit)

The Standard Mounting Kit is always included for devices for mounting version "A".

MKA-FT

Feedthrough assembly for higher protection classes or enhanced cooling characteristics.

MKA-CP

Mounting kit for Coldplate mounting version "C".

MKA-CPF

Optional thermally conductive foil for Coldplate mounting devices.

MOUNTING OF FRAME SIZE 1

AxiaVert	Mounting	Description
	Standard MKA-STD1&2&3-01	Standard mounting
AXV20xxxxx1xxxxxxx AXV40xxxxx1xxxxxxx	MKA-FT1-01	Feedthrough mounting
	MKA-CP1&2-01	ColdPlate mounting
	MKA-CPF1&2-01	Thermally conductive foil for ColdPlate mounting

MKA-STD1&2&3-01

(Standard mounting)

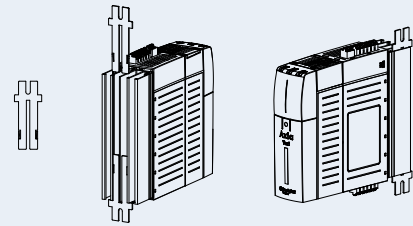

MKA-FT1-01

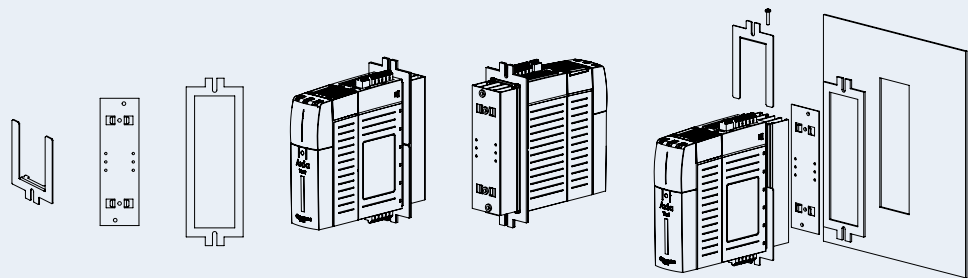

MKA-CP1&2-01

The mounting kit MKA-CP1&2-01 is part of delivery for ColdPlate devices.

The optional thermally conductive foil MKA-CPF1&2-01 is engineered to optimize thermal transition performance between the device's backside and the thermal connection with the application.

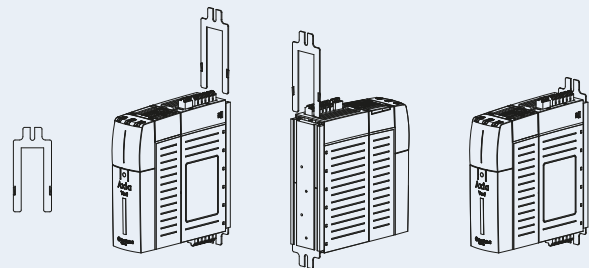

MOUNTING OF FRAME SIZE 2

AxiaVert	Mounting	Description
	Standard MKA-STD1&2&3-01	Standard mounting
AXV20xxxxx2xxxxxxx AXV40xxxxx2xxxxxxx	MKA-FT2-01	Feedthrough mounting
	MKA-CP1&2-01	ColdPlate mounting
	MKA-CPF1&2-01	Thermally conductive foil for ColdPlate mounting

MKA-STD1&2&3-01

(Standard mounting)

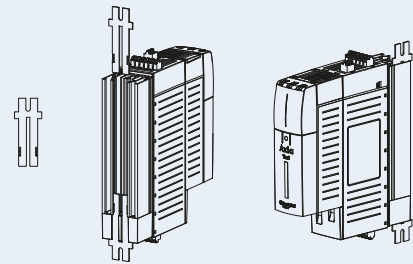

MKA-FT2-01

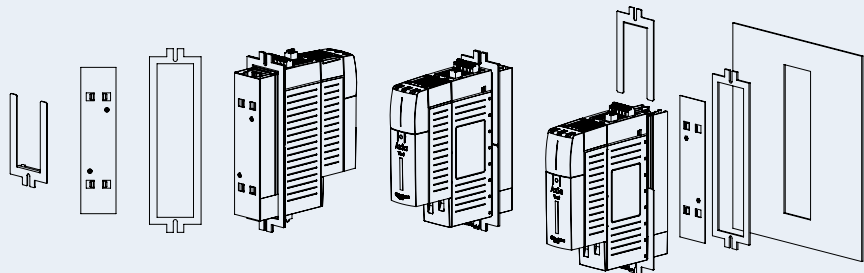

MKA-CP1&2-01

The mounting kit MKA-CP1&2-01 is part of delivery for ColdPlate devices.

The optional thermally conductive foil MKA-CPF1&2-01 is engineered to optimize thermal transition performance between the device's backside and the thermal connection with the application.

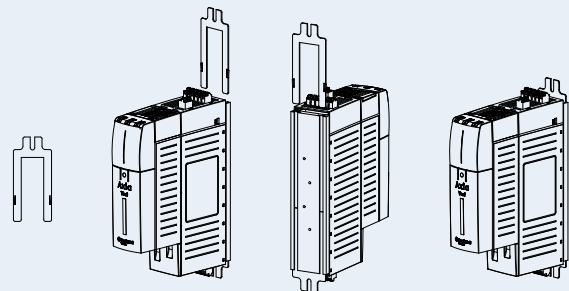

MOUNTING OF FRAME SIZE 3

AxiaVert	Mounting	Description
	Standard MKA-STD1&2&3-01	Standard mounting
AXV20xxxxx3xxxxxxx AXV40xxxxx3xxxxxxx	MKA-FT3-01	Feedthrough mounting
	MKA-CP3-01	ColdPlate mounting
	MKA-CPF3-01	Thermally conductive foil for ColdPlate mounting

MKA-STD1&2&3-01

(Standard mounting)

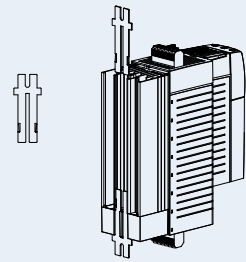

MKA-FT3-01

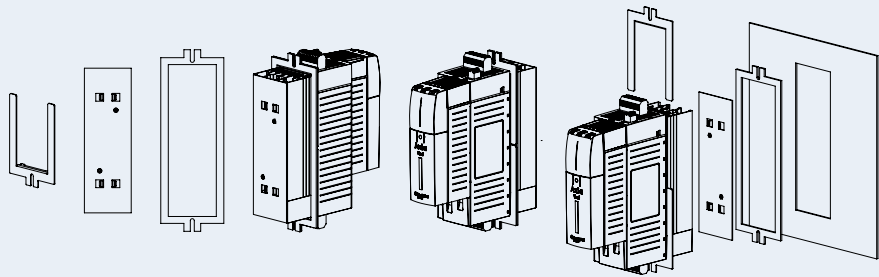

MKA-CP3-01

The mounting kit MKA-CP3-01 is part of delivery for ColdPlate devices.
The optional thermally conductive foil MKA-CPF3-01 is engineered to optimize thermal transition performance between the device's backside and the thermal connection with the application.

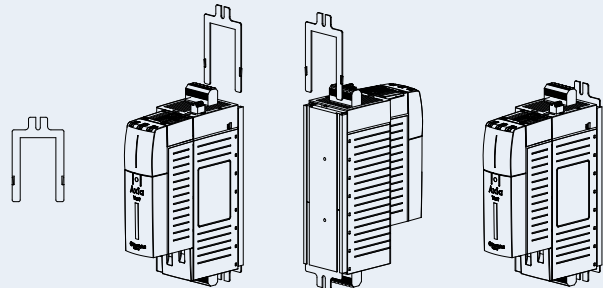

MOUNTING OF FRAME SIZE 4

AxiaVert	Mounting	Description
	Standard MKA-STD4-01	Standard mounting
AXV20xxxxx4xxxxxxx	MKA-FT4-01	Feedthrough mounting
AXV40xxxxx4xxxxxxx	MKA-CP4-01	ColdPlate mounting
	MKA-CPF4-01	Thermally conductive foil for ColdPlate mounting

MKA-STD4-01

(Standard mounting)

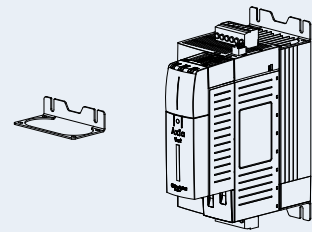

MKA-FT4-01

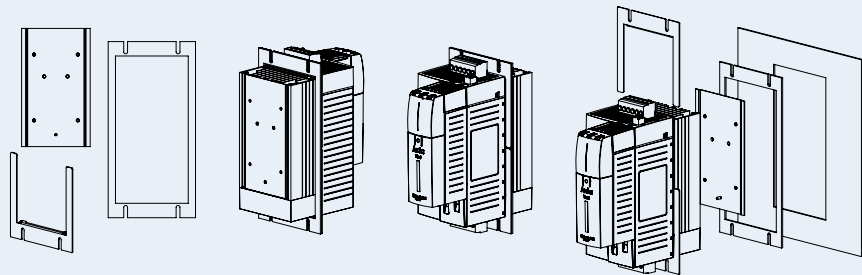

MKA-CP4-01

The mounting kit MKA-CP4-01 is part of delivery for ColdPlate devices. The optional thermally conductive foil MKA-CPF4-01 is engineered to optimize thermal transition performance between the device's backside and the thermal connection with the application.

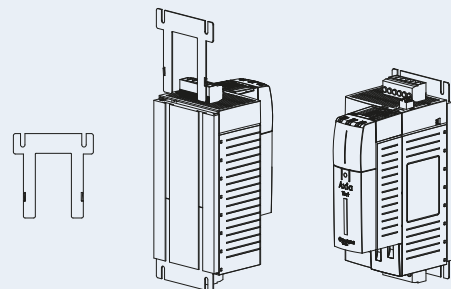

EMC OVERVIEW

EMC COMPLIANCE

AxiaVert devices are developed and designed to be used as components inside machinery installations and systems. **The devices comply with the EMC product standard EN61800-3.** Depending on the environment, where the machine is used (first environment or second environment according to EN61800-3) line chokes or EMI filters can be used to achieve the desired EMC level. The EMC categories of EN61800-3 can always be aligned to a group level of EN55011. Note, that this alignment is valid for the direction from EN61800-3 to EN55011, but that an alignment from EN55011 to EN61800-3 can lead to unclear results and therefore should be avoided.

EMC standards

EMC according to EN61800-3 ⁽¹⁾	Category EN61800-3	Group EN55011
First environment, unrestricted distribution	Category C1	Group 1, Class B
First environment, restricted distribution	Category C2	Group 1, Class A
Second environment, unrestricted distribution	Category C3	Group 2, Class A

BACKGROUND FOR EMI FILTERS AND LINE CHOKES

An Input Filter is an electrical component to be installed up-line from the frequency inverter and down-line from the power feeding contactor.

The AC/DC rectifier at the inverter input generates harmonic disturbance on the absorbed current and emits disturbance generated by switching components towards the mains.

This harmonic current causes voltage distortions on the mains, resulting in electromagnetic interference phenomena.

This harmonic distortion is reduced by means of line chokes, while disturbance is countered with EMI filters (attenuation of EMI voltages) such as those described below.

Note: the use of input filters reduces the inverter input voltage. When line chokes and EMI filters are used, the following schematic installation order should be considered:

1. Mains supply
2. Line choke (usage depending on system requirements)
3. EMI filter (usage depending on system requirements)
4. Inverter

(1) EN61800-3: Adjustable speed electrical power drive systems - Part 3: EMC requirements and specific test methods.



FERRITE CORE

- Installing a Ferrite Core on the line side can effectively reduce EMC emissions and provide a cost-effective solution for improving EMC behavior. It requires minimal installation efforts and does not require additional cabinet space.

LINE CHOKE

- The use of line chokes depends on the system engineer's need to reduce harmonic distortion in the short-circuit point and the need to reinforce the action of the EMI filter. A line choke is normally used if the mains short-circuit power is lower than 1%.
- A line choke is recommended for the AXV20 and AXV40 frequency inverter series in the presence of high continuous input current required by the application, in order to increase the lifetime of the electrolytic capacitors.
- A line choke is always required in single and two-phase operation of the AXV frequency inverters. For three-phase installations please check the markings in the technical data tables.

EMI FILTER

- An EMI filter is useful for achieving higher EMC Classes (such as C1 or C2) that require additional filters for compliance.

EMC COMPLIANCE

- The following table summarizes for the AXV frame sizes the EMC compliance category in combination with components where required.

EN61800-3	Compliance with Category C3		Compliance with Category C2	
Motor cable length	< 10 m	< max*	< 10 m	< max*
AXV size 1	Ferrite core or External filter	External filter	External filter	External filter
AXV size 2	Ferrite core or External filter	External filter	External filter	External filter
AXV size 3	External filter	External filter	External filter	External filter
AXV size 4	External filter	External filter	External filter	External filter

FERRITE CORE



A cost-effective solution for improving EMC behavior is the installation of a Ferrite Core on the mains side. This approach reduces EMC emissions, leading to enhanced performance with minimal installation effort and no need for additional cabinet space. Ferrite cores serve to suppress common mode disturbances on power and motor lines, resulting in a reduction of emitted interferences.

TECHNICAL DATA

Operating temperature

- -40 °C up to +125 °C

Storage conditions

- <40 °C; < 75 % RH

COMPATIBILITY

Ferrite Core FC10 – AC mains (L1,L2,L3):

- Frame size 1
- Frame size 2

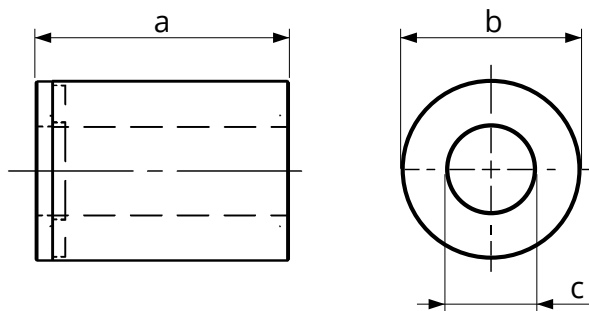

TECHNICAL ASSEMBLY DATA

Ferrite Core	Dimensions			Cable diameter max.	Weight
	a	b	c		
	[mm]	[mm]	[mm]	[mm]	[kg]
FC10	30	21.3	10.5	10.2	0.03

LINE CHOKE

The simplest way to reduce high harmonic components and hence reactive power is connecting a choke in series on the mains side of the inverter. Depending on the system, reactive power consumption can be reduced by approximately 20% of the figure without line choke.

The line choke increases inductance towards the mains. Mains feed line choke can be regarded as sufficient if short-circuit power is from 20 to 40 times higher than the inverter nominal output.

The inverter is suitable for connection to public or industrial mains supplies in compliance with technical data. If the supply mains transformer output is ≤ 500 kVA, the optional mains choke is needed only if specified in the inverter technical data. The other inverters are suitable for the connection to the mains without a mains choke with relative impedance $\geq 1\%$. If it is desired to connect more than one inverter, use the sum of the nominal outputs as a basis. Since experience has shown that the nominal short-circuit power on the inverter connection point is often unknown, Bonfiglioli recommends using mains chokes with 4% relative short-circuit voltage.

The relative short-circuit voltage equivalent to a 4% voltage drop represents the percentage of the nominal voltage at which a current equal to rated current flows in the case of a short-circuit.

TECHNICAL DATA

Nominal voltages

- AC 1 x 230V +/- 10%
- AC 3 x 230V +/- 10%
- AC 3 x 400V +/- 10%

Frequencies

- 50/60 Hz
- u_k (a IN / 50 Hz) 4%

Insulating material class

- T40/F

Ambient temperature

- 40°C

Protection degree (EN 60529)

- IP00

Connection type

- Contact-protected terminals

The line choke must be installed between the mains connection point and the EMI filter. Both the line choke and inverter should be installed on a common metal baseplate and each should be connected to the metal mounting plate and earthed by means of a large contact area copper braid.

LCVS006 ... LCVS018

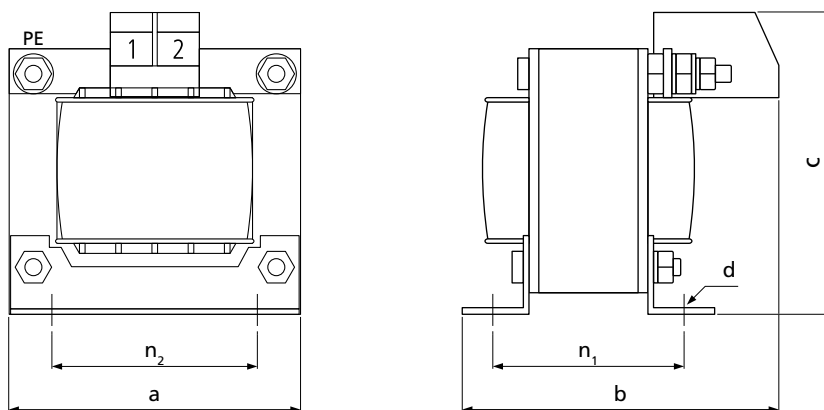

TECHNICAL DATA

AxiaVert frequency inverter - Line choke combination, 1x230V~

Inverter type	Line choke	Nominal current [A]	Power dissipation [W]
AXV20xxk25	LCVS006	6	8.0
AXV20xxk37			
AXV20xxk55			
AXV20xxk75	LCVS008	8	8.0
AXV20xx1k1	LCVS010	10	10.0
AXV20xx1k5	LCVS015	15	12.0
AXV20xx2k2	LCVS018	18	15.0

TECHNICAL ASSEMBLY DATA

Line choke	Dimensions			Assembly			Weight [kg]	Connection terminal		
	a [mm]	b [mm]	c [mm]	n ₂ [mm]	n ₂ [mm]	d [mm]		[mm]	[Nm]	[PE]
LCVS006	60	62	75	44	38	3.6	0.5	0.75-2.5	1.0-1.2	2.5 mm ²
LCVS008	60	67	75	44	43	3.6	0.6	0.75-2.5	1.0-1.2	2.5 mm ²
LCVS010	66	80	70	50	51	4.8	0.8	0.75-2.5	1.0-1.2	M4
LCVS015	78	78	80	56	49	4.8	1.1	0.75-4.0	1.5-1.8	M4
LCVS018	85	85	95	64	50	4.8	1.8	0.75-4.0	1.5-1.8	M4

LINE CHOKE

LCVT004 ... LCVT025

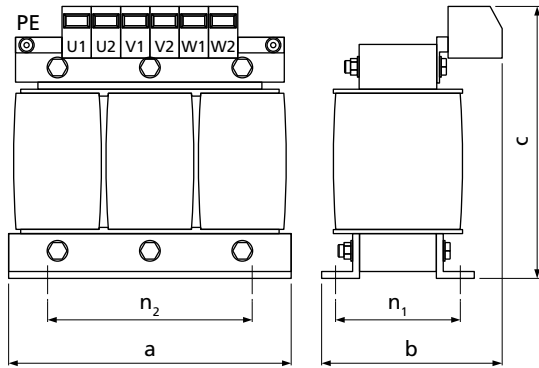

LCVT034 ... LCVT250

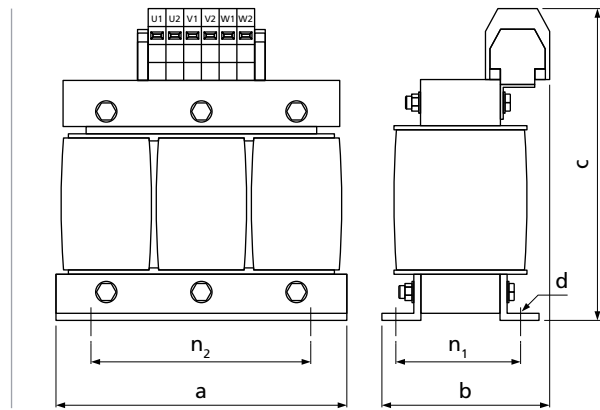

LCVT280AL-xxx ... LCVT690AL-xxx

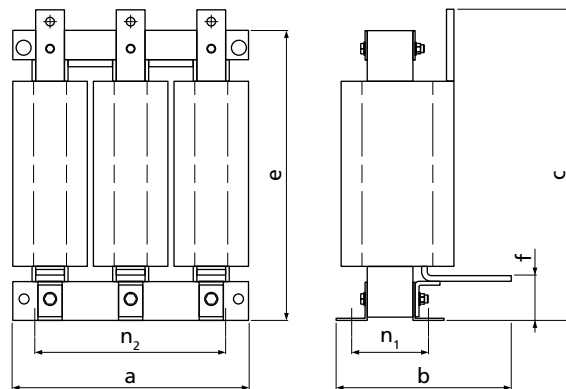

TECHNICAL DATA

AxiaVert frequency inverter – Line choke combination, 3x230V~

Inverter type	Line choke	Nominal current	Choke	Power dissipation
		[A]	[mH]	[W]
AXV20xxk25	LCVT004	4	7.32	20
AXV20xxk37				
AXV20xxk55				
AXV20xxk75				
AXV20xx1k1	LCVT006	6	4.88	25
AXV20xx1k5	LCVT008	8	3.66	30
AXV20xx2k2	LCVT010	10	2.93	30
AXV20xx3k0	LCVT015	15	1.95	45
AXV20xx4k0	LCVT018	18	1.63	70
AXV20xx5k5	LCVT025	25	1.17	70
AXV20xx7k5	LCVT034	34	0.86	85
AXV20xx9k2				

TECHNICAL DATA

AxiaVert frequency inverter – Line choke combination, 3x400V~

Inverter type	Line choke	Nominal current	Choke	Power dissipation
		[A]	[mH]	[W]
AXV40xxk25	LCVT004	4	7.32	20
AXV40xxk37				
AXV40xxk55				
AXV40xxk75				
AXV40xx1k1				
AXV40xx1k5				
AXV40xx1k9	LCVT006	6	4.88	25
AXV40xx2k2	LCVT008	8	3.66	30
AXV40xx4k0	LCVT010	10	2.93	30
AXV40xx5k5	LCVT015	15	1.95	45
AXV40xx7k5	LCVT018	18	1.63	70
AXV40xx9k2	LCVT025	25	1.17	70
AXV40xx11k	LCVT025	25	1.17	70
AXV40xx15k	LCVT034	34	0.86	85

TECHNICAL ASSEMBLY DATA

Line choke	Dimensions			Assembly			Weight	Connection terminal		
	a	b	c	n2	n1	d		[mm]	[Nm]	[PE]
	[mm]	[mm]	[mm]	[mm]	[mm]	[mm]	[kg]	[mm]	[Nm]	[PE]
LCVT004	80	65	95	55	37	4	0.8	0.75-2.5	1.0-1.2	4 mm ²
LCVT006	100	65	115	60	39	4	1.0	0.75-2.5	1.0-1.2	4 mm ²
LCVT008	100	75	115	60	48	4	1.5	0.75-2.5	1.0-1.2	4 mm ²
LCVT010	100	75	115	60	48	4	1.5	0.75-2.5	1.0-1.2	4 mm ²
LCVT015	125	85	135	100	55	5	3.0	0.75-4.0	1.5-1.8	4 mm ²
LCVT018	155	90	135	130	57	8	4.0	0.75-4.0	1.5-1.8	4 mm ²
LCVT025	155	100	160	130	57	8	4.0	0.75-10	4.0-4.5	4 mm ²
LCVT034	155	100	190	130	57	8	4.5	2.5-16	2.0-4.0	M5
LCVT050	155	115	190	130	72	8	4.5	2.5-16	2.0-4.0	M5
LCVT060	190	110	220	170	58	8	9.0	2.5-35	2.5-5.0	M5
LCVT075	190	120	250	170	68	8	12	25-50	3.0-6.0	M6
LCVT090	190	130	250	170	78	8	12	25-50	3.0-6.0	M6
LCVT115	210	140	270	180	82	8	14	25-50	3.0-6.0	M6
LCVT135	240	160	300	190	100	11	20	16-70	6.0-7.0	M8
LCVT160	240	160	310	190	100	11	20	50-95	6.0-12.0	M8
LCVT180	240	175	320	190	106	11	22	50-95	6.0-12.0	M8
LCVT210	240	200	335	190	121	11	26	95-150	10.0-20.0	M8
LCVT250	240	210	350	190	126	11	28	95-150	10.0-20.0	M8



EMI FILTERS



Because of their intrinsic characteristics, all frequency inverters often generate undesired high-frequency voltages generally referred to as “interference”. Mains filters are installed to reduce this interference.

The reference standard EN 61800-3 defines the thresholds for electromagnetic interference for different classes of equipment.

AxiaVert series frequency inverters **up to size 9.2 kW** can be ordered with a **built-in EMI filter** conforming to the requirements of the standard for “class A – group 2” environments corresponding to **EMC category C3**.

Two series of external interference filters are available for larger size AxiaVert frequency inverters and for installations where conformity to the stricter **requirements of class B / category C1** is necessary. The two series differ both in construction and power range.

The first set of filters are “**backplate filters or foot print**”. They are available in sizes from 7 to 40 A (suitable for AxiaVert frequency inverters up to size 4), and allow the frequency inverter to be installed on board of the filter itself. The second series of filters are “**book filters**”. They cover all other AxiaVert sizes and are designed for installation on the same mounting panel alongside the drive.

Mains filters with very low dispersion currents are available upon request for specific applications.

BASIC CIRCUIT DIAGRAM

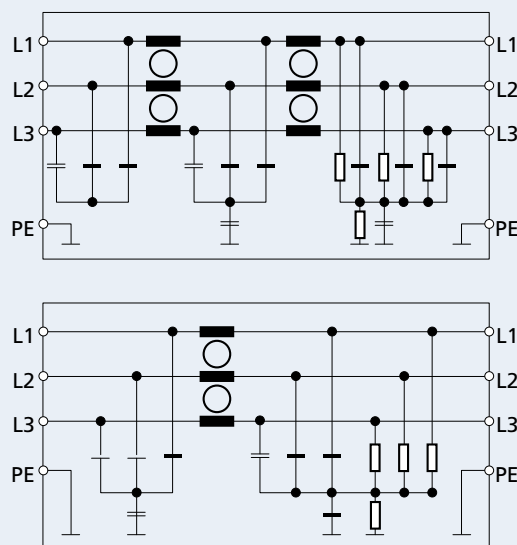

BACKPLATE EMI FILTERS

Mains voltage

- AC 3 x 480 V~ maximum +10%

Nominal current

- 8A ... 40A

Frequency

- 50/60 Hz

Operating and storage temperature

- -25 °C ... +100 °C (climate class acc. to EN60721-3-3)

Ambient temperature

- +40°C maximum

Protection degree (EN 60529)

- IP00

Connection type

- Contact-protected terminals
- Strand connection on load side (up to AXV40xx4k0)
- Metal fasteners are included in the supply

Note

These mains filters are installed between the line choke and the frequency inverter. The frequency inverter installed on the EMI filter must be connected to the metal baseplate with a short, large section earth connection.

Overload capacity is 1.5 times rated current for 1 minute, every 30 minutes.

Inverter type		EMI filter	Rated current	Leakage current	Power dissipation	Weight
Size	Type		[A]	[mA]	[W]	[kg]
3	AXV40xx5k5	FTV018B	18	1.5	20	3.5
	AXV40xx7k5					
4	AXV40xx11k	FTV040B	40	1.2	35	3.5
	AXV40xx15k					

BACKPLATE EMI FILTERS

DIMENSIONS FTV018B - FTV040B

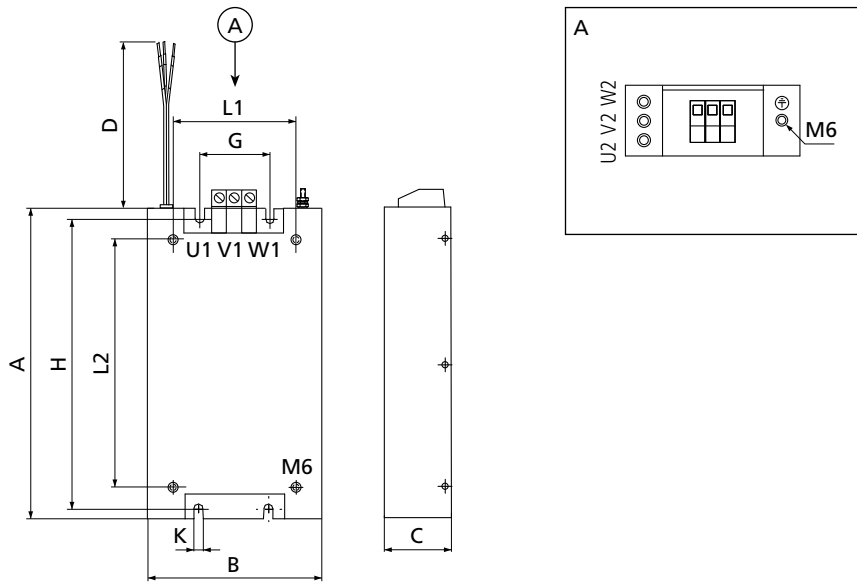

EMI filter	A	B	C	D	G	H	K	L1	L2
	[mm]								
FTV018B	315	100	65	300	35	300	6.3	76	270
FTV040B	315	125	65	300	60	300	6.3	125	270

BOOK TYPE EMI FILTERS

Mains voltage

- AC 3 x 480 V

Rated current

- 7 A ... 55 A

Frequency

- up to 60 Hz

Operating and storage temperature

- -25 °C ... +80 °C (climate class acc. to EN60721-3-3)

Protection degree (EN 60529)

- IP20

Maximum length of motor cables:

- AXV40xxk25 to AXV40xx3k0: 25 m class B
- AXV40xx4k0 to AXV40xx15k: 50 m class B

Note

Overload capacity is 4 times rated current at switch-on; 1.5 times rated current for 1 minute, once per hour.

Inverter type		EMI filter	Rated current	Leakage current	Power dissipation	Weight
Size	Type		[A]	[mA]	[W]	[kg]
1	AXV20xxk25	HLD 110-500/8	8	20	6	0.8
	AXV20xxk37					
	AXV20xxk55					
	AXV20xxk75					
	AXV20xx1k1					
	AXV40xxk25					
	AXV40xxk37					
	AXV40xxk55					
	AXV40xxk75					
	AXV40xx1k1					
	AXV40xx1k5					
2	AXV20xx1k5	HLD 110-500/16	16	21	12	1.2
	AXV40xx1k9					
	AXV40xx2k2					
	AXV40xx3k0					
	AXV20xx2k2					
3	AXV20xx4k0	HLD 110-500/30	30	29	15	1.6
	AXV20xx5k5					
	AXV40xx9k2					
	AXV20xx7k5					
4	AXV40xx11k	HLD 110-500/55	55	30	30	2.6
	AXV40xx15k					
	AXV20xx9k2					

BOOK TYPE EMI FILTERS

DIMENSIONS HLD 110-500/8 ... HLD 110-500/55

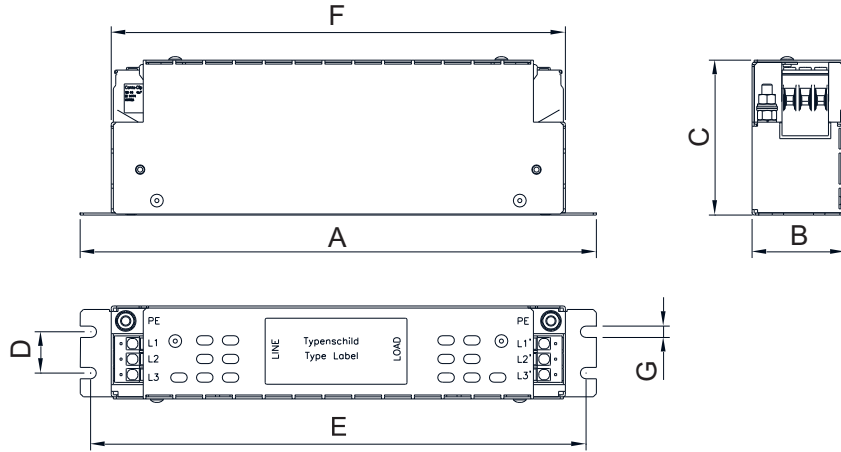

EMI filter	A	B	C	D	E	F	G
	[mm]						
HLD 110-500/8	190	45	75	20	180	166	M5
HLD 110-500/16	250	45	75	20	240	220	M5
HLD 110-500/30	270	55	95	30	255	240	M5
HLD 110-500/55	250	85	95	60	235	255	M5

BRAKING RESISTORS

When speed of an inverter-controlled AC motor is reduced, the motor acts as a generator, feeding back energy to the frequency inverter. As a result, voltage in the DC circuit of the inverter increases. When a specific threshold is exceeded, the energy must flow to an external braking system in order to avoid drive failures. Braking resistors are designed to absorb such energy and to dissipate it into heating. The use of brake resistors allows drives to fulfil the requirements of particularly severe duty cycles, for example those featured by frequent braking, long lasting braking or impulsive braking.

Bonfiglioli offers a wide range of safe and compact braking resistors with IP20 degree of protection: "BR series".

BR series are designed for panel mounting.

Depending on the brake resistors these are equipped with a thermal switch (see selection table for details).



CONNECTION DIAGRAM

R_b = external braking resistor

Bch = brake chopper integrated in standard AxiaVert inverter

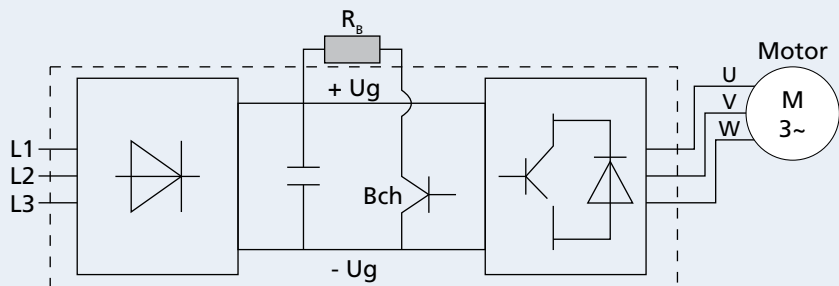

CONNECTION TERMINALS

The R_{b1} and R_{b2} braking resistor terminals on AxiaVert frequency inverters are located on the X2 power output terminal strip. Access to these terminals on sizes 1 to 4 units is made even easier by the use of disconnectable power terminal strips. Refer to the manual provided with your frequency inverter for further details on materials and connection methods.

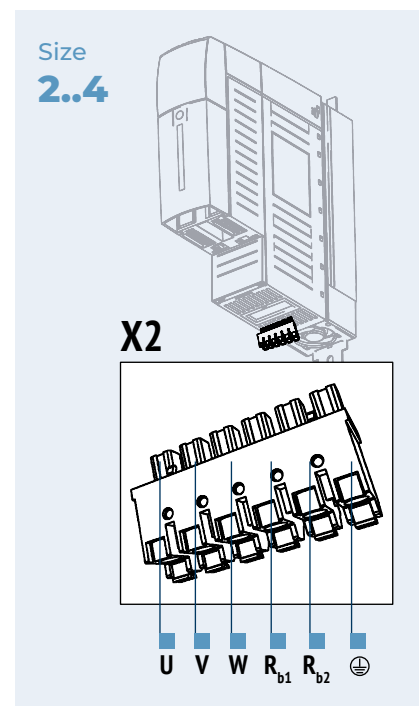
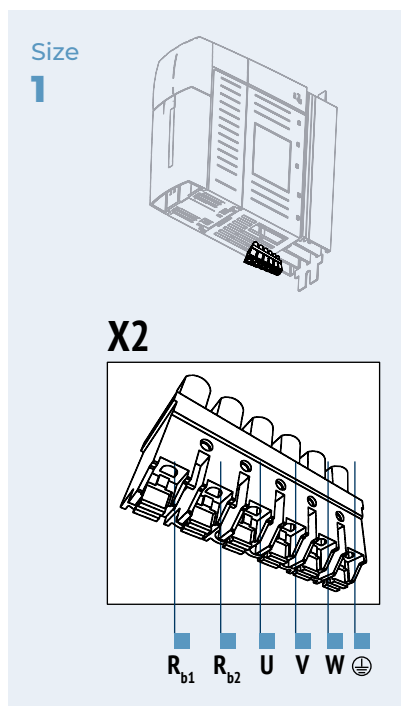

BRAKING RESISTORS

AXIAVERT DRIVE COMBINATION CHART

These charts show recommended combinations for each model in the AxiaVert range, and specify the corresponding duty cycles based on the rated drive power. Contact your nearest Bonfiglioli Support Centre for particularly heavy-duty braking applications or if you need to customize a product.

Inverter type	Braking resistor	Resistance	Continuous rated power	Duty cycle at the drive's rated power	
kW		Ohm	[W]	[%]	
AXV20xxk25	0.25	BR 160/100 ⁽¹⁾	100	160	64%
AXV20xxk37	0.37	BR 160/100 ⁽¹⁾	100	160	43%
AXV20xxk55	0.55	BR 160/100 ⁽¹⁾	100	160	29%
AXV20xxk75	0.75	BR 160/100 ⁽¹⁾	100	160	21%
AXV20xx1k1	1.1	BR 160/100 ⁽¹⁾	100	160	15%
AXV20xx1k5	1.5	BR 432/37 ⁽¹⁾	37	432	29%
AXV20xx2k2	2.2	BR 432/37 ⁽¹⁾	37	432	20%
AXV20xx3k0	3	BR 432/37 ⁽¹⁾	37	432	14%
AXV20xx4k0	4	BR 667/24 ⁽²⁾	24	667	17%
AXV20xx5k5	5.5	BR 667/24 ⁽²⁾	24	667	12%
AXV20xx7k5	7.5	BR 1333/12 ⁽²⁾	12	1333	18%
AXV20xx9k2	9.2	BR 1333/12 ⁽²⁾	12	1333	14%
AXV40xxk25	0.25	BR 213/300 ⁽¹⁾	300	213	85%
AXV40xxk37	0.37	BR 213/300 ⁽¹⁾	300	213	57%
AXV40xxk55	0.55	BR 213/300 ⁽¹⁾	300	213	39%
AXV40xxk75	0.75	BR 213/300 ⁽¹⁾	300	213	28%
AXV40xx1k1	1.1	BR 213/300 ⁽¹⁾	300	213	19%
AXV40xx1k5	1.5	BR 213/300 ⁽¹⁾	300	213	14%
AXV40xx1k9	1.85	BR 471/136 ⁽¹⁾	136	471	25%
AXV40xx2k2	2.2	BR 471/136 ⁽¹⁾	136	471	21%
AXV40xx3k0	3	BR 471/136 ⁽¹⁾	136	471	16%
AXV40xx4k0	4	BR 696/92 ⁽²⁾	92	696	17%
AXV40xx5k5	5.5	BR 1330/48 ⁽²⁾	48	1330	24%
AXV40xx7k5	7.5	BR 1330/48 ⁽²⁾	48	1330	18%
AXV40xx9k2	9.2	BR 1330/48 ⁽²⁾	48	1330	14%
AXV40xx11k	11	BR 2000/32 ⁽²⁾	32	2000	18%
AXV40xx15k	15	BR 2000/32 ⁽²⁾	32	2000	13%

(1) Brake resistor is not equipped with a Thermal switch. A thermal switch variant is available.

(2) Brake resistor is equipped with a Thermal switch.

For further information refer to the Bonfiglioli braking resistor catalogue.



OUR GLOBAL PRESENCE

Thanks to an international network of closely interconnected commercial and production sites, we can guarantee the same high standards of Bonfiglioli quality anywhere at any given time. We know that our direct presence in local markets is the key to long-lasting success, so our family includes 17 production sites, 23 commercial sites and more than 550 distributors around the world.

Our organization is always close by, offering complete and efficient solutions and supporting our customers with dedicated services, co-engineering and after-sales assistance.



17

PRODUCTION SITES



23

COMMERCIAL SITES



80

COUNTRIES



550

DISTRIBUTORS



~5,000

PEOPLE

AUSTRALIA

Bonfiglioli Transmission (Aust.) Pty Ltd

2, Cox Place Glendenning NSW 2761
Locked Bag 1000 Plumpton NSW 2761
Tel. +61 2 8811 8000



BRAZIL

Bonfiglioli Redutores do Brasil Ltda

Av. Osvaldo Fregonezi, 171, cjs 31 e 44
CEP 09851-015 - São Bernardo do Campo
São Paulo
Tel. +55 11 4344 2322



CHINA

Bonfiglioli Drives (Shanghai) Co. Ltd.

#68, Hui-Lian Road, QingPu District,
201707 Shanghai
Tel. +86 21 6700 2000



Selcom Electronics (Shanghai) Co., Ltd

A7, No.5399, Waiqingsong Road, QingPu
District,
201707 Shanghai
Tel. +86 21 6010 8100



A24, No.5399, Waiqingsong Road, QingPu
District,

201707 Shanghai
Tel. +86 21 6010 8100



FRANCE

Bonfiglioli Transmission S.A.S.

14 Rue Eugène Pottier
Zone Industrielle de Moimont II
95670 Marly la Ville
Tel. +33 1 34474510



GERMANY

Bonfiglioli Deutschland GmbH

Sperberweg 12 - 41468 Neuss
Tel. +49 0 2131 2988 0



Bonfiglioli Deutschland GmbH

Europark Fichtenhain B6 - 47807 Krefeld
Tel. +49 0 2151 8396 0



O&K Antriebstechnik GmbH

Ruhrallee 8-12 - 45525 Hattingen
Tel. +49 0 2324 2050 1



INDIA

Bonfiglioli Transmission Ltd.

Mobility & Wind Industries

AC 7 - 11, SIDCO Industrial Estate,
Thirumudivakkam
Kancheepuram - 600132 - Tamil Nadu
Tel. +91 844 844 8649



Industry & Automation Solutions

Survey No. 528/1, Perambakkam High Road
Mannur Village, Sriperumbudur Taluk
Kancheepuram - 602 105 - Tamil Nadu
Tel. +91 844 844 8649



Industry & Automation Solutions

Plot No E-5/2, Badhalwadi
Talegaon MIDC Phase II,
Pune - 410 507 - Maharashtra
Tel. +91 844 844 8649



ITALY

Bonfiglioli Riduttori S.p.A.

Industry & Automation Solutions

Via Cav. Clementino Bonfiglioli, 1
40012 Calderara di Reno
Tel. +39 051 6473111



Industry & Automation Solutions

Via Sandro Pertini, lotto 7b
20080 Carpiano
Tel. +39 02985081



Mobility & Wind Industries

Via Enrico Mattei, 12 Z.I. Villa Selva
47122 Forlì
Tel. +39 0543 789111



Industry & Automation Solutions

Via Unione, 49 - 38068 Rovereto
Tel. +39 0464 443435/36



Selcom Group S.p.A.

Via Achille Grandi, 5
40013 Castel Maggiore (BO)
Tel. +39 051 6387111



Via Marino Serenari, 18
40013 Castel Maggiore (BO)
Tel. +39 051 6387111



Via Cadriano, 19
40057 Cadriano (BO)
Tel. +39 051 6387111



NEW ZEALAND

Bonfiglioli Transmission (Aust.) Pty Ltd

88 Hastie Avenue, Mangere Bridge,
2022 Auckland
PO Box 11795, Ellerslie
Tel. +64 09 634 6441



SINGAPORE

Bonfiglioli South East Asia Pte Ltd

8 Boon Lay Way, #04-09,
8@ Tadehub 21, Singapore 609964
Tel. +65 6268 9869



SLOVAKIA

Bonfiglioli Slovakia s.r.o.

Robotnícka 2129
Považská Bystrica, 01701 Slovakia
Tel. +421 42 430 75 64



SOUTH AFRICA

Bonfiglioli South Africa Pty Ltd.

55 Galaxy Avenue, Linbro Business Park,
Sandton, Johannesburg
2090 South Africa
Tel. +27 11 608 2030



SPAIN

Tecnotrans Bonfiglioli S.A

Avinguda del Ferrocarril, nº 14,
Polígono Industrial Can Estapé
08755 Castellbisbal - Barcelona
Tel. +34 93 447 84 00



TURKEY

Bonfiglioli Türkiye Jsc

Atatürk Organize Sanayi Bölgesi,
10007 Sk. No. 30
Atatürk Organize Sanayi Bölgesi,
35620 Çiğli - Izmir
Tel. +90 0 232 328 22 77



UNITED KINGDOM

Bonfiglioli UK Ltd.

Unit 1 Calver Quay, Calver Road, Winwick
Warrington, Cheshire - WA2 8UD
Tel. +44 1925 852667



USA

Bonfiglioli USA Inc.

3541 Hargrave Drive
Hebron, Kentucky 41048
Tel. +1 859 334 3333



VIETNAM

Bonfiglioli Vietnam Co. Ltd.

Lot C-9D-CN, My Phuoc 3 Industrial Park,
Thoi Hoa ward, Ben Cat city, Binh Duong
province, Vietnam
Tel. +84 274 3577411





We have a relentless commitment to excellence, innovation & sustainability. Our team creates, distributes and services world-class power transmission & drive solutions to keep the world in motion.

HEADQUARTERS

Bonfiglioli S.p.A

Via Cav. Clementino Bonfiglioli, 1
40012 Calderara di Reno - Bologna (Italy)
Tel. +39 051 6473111

