



3/H Series

HEAVY DUTY MODULAR GEAR UNITS





We engineer dreams



INDEX

GENERAL INFORMATION	4		
1. SYMBOLS AND UNITS OF MEASUREMENT	5		
2. GENERAL DESIGN FEATURES	6		
3. INSTALLATION	7		
4. LUBRICATION	8		
4.1. Selection of the optimal oil viscosity (data refers to Shell oils)	8	16.1.3 Auxiliary cooling with autonomous cooling unit	28
4.2. Lubrication for 3/H gear units	9	16.1.4 Forced motor pump lubrication	32
5. STORAGE	10	16.1.5 Heaters – he option	33
6. CONDITIONS OF SUPPLY	10	16.2 Drain valve	34
7. PAINT COATING	10	16.3 Backstop device	35
8. SERVICE FACTOR	11	16.4 Primary brand bearings	38
9. SIZING	12	16.5 Seals and gaskets	38
10. VERIFICATION	14	16.6 Vent filter with drying salts	38
10.1 Motor availability	14	16.7 Sensors	38
10.2 Backstop device	14	16.8 Fixing elements	39
10.3 Radial load bearing capacity check	14	16.9 Surface protection	40
10.4 Radial and axial loads on input shaft	16	16.10 Paint coating	40
10.5 Thermal power	16	16.11 Long-term storage	41
		16.12 Certificates	42
		TECHNICAL DATA	44
		17. PERFORMANCE AND THERMAL POWER	45
		18. MOMENT OF INERTIA	76
3/H SERIES GEAR UNIT	18	DIMENSIONS AND WEIGHTS	78
11. DESIGN FEATURES	19	19. DIMENSIONS AND WEIGHTS	79
12. PRODUCT CONFIGURATIONS	20	20. MOTOR ADAPTER DIMENSIONS WITH BELL HOUSING AND IEC FLEXIBLE COUPLING [mm]	104
12.1 Basic variants	20	21. MOTOR ADAPTER DIMENSIONS WITH BELL HOUSING AND NEMA FLEXIBLE COUPLING [inch]	104
12.2 Optional variants	21	22. MOTOR MAXIMUM STATIC LOAD VALUES	106
12.3 Mounting position	22	23. CUSTOMER SHAFT	107
13. INPUT AND OUTPUT CONFIGURATION	22	24. CUSTOMER SHAFT	108
13.1 Output shaft configuration	22		
13.2 Input shaft configuration	22		
14. OUTPUT SHAFT ARRANGEMENT	23		
15. MOTOR ADAPTER	23		
16. OPTIONAL VARIANTS	26		
16.1 Auxiliary thermal devices	26		
16.1.1 Forced ventilation	26		
16.1.2 Heat dissipation through cooling coil	27		



General information





1. SYMBOLS AND UNITS OF MEASUREMENT

Symbol	Unit of measurement	Description
$An_{1,2}$	[kN]	Permissible axial force
f_s	-	Service factor
i	-	Gear ratio
l	-	Cyclic duration factor
J	[Kgm ₂]	Moment of inertia
$M_{1,2}$	[Nm]	Torque
$Mc_{1,2}$	[Nm]	Calculated torque
$Mn_{1,2}$	[Nm]	Rated torque
$Mr_{1,2}$	[Nm]	Torque demand
Mn_{2max}	[Nm]	Maximum transmissible torque
M_{2max}	[Nm]	Maximum static torque
Mfs	[Nm]	Static bending moment

Symbol	Unit of measurement	Description
$n_{1,2}$	[min ⁻¹]	Speed
$P_{1,2}$	[kW]	Power
PTB	[kW]	Base thermal power
PT_{FAN}	[kW]	Thermal power with FAN
$Pn_{1,2}$	[kW]	Rated power
$Pr_{1,2}$	[kW]	Power demand
P_T	[kW]	Thermal power
$Rc_{1,2}$	[kN]	Calculated radial force
$Rn_{1,2}$	[kN]	Permissible overhung load
t_a	[°C]	Ambient temperature
t_s	[°C]	Surface temperature
t_o	[°C]	Oil temperature
η	-	Efficiency

₁ value referring to the input shaft

₂ value referring to the output shaft



2. GENERAL DESIGN FEATURES

The 3/H solution combines the technological, performance and efficiency advantages of the planetary gear unit series with the robustness, quality and reliability of the helical bevel gear unit series.

The combined planetary/helical bevel gear units combine the advantages of the high torque transmission achievable with the 300 series with the optimal power transmission achievable with the HDO series, allowing them to be used in applications requiring high power density and medium to low output speeds.

The product range has a transmission capacity (Mn_2) of up to 1,200 kNm, available in 15 sizes included in the catalogue, with customised combinations available on request.

The wide range of ratios and, above all, the availability of several intermediate sizes make the 3/H solution the most complete for the different requirements of the reference applications.

Compared to traditional technologies, the flexibility and synergy of the 3/H combined gear units mainly offer the following benefits:

- Torque extension
- Thermal power
- Compactness
- Low noise
- Versatile solutions and available accessories.



3. INSTALLATION

It is very important to respect the following rules when installing the gear unit:

- Ensure that the gear unit is securely fastened to prevent any vibration. Install hydraulic couplings, clutches, torque limiters, etc. (if impacts, prolonged overloads or possible blockages are expected).
- Before paint coating, protect the machined surfaces and the outer edge of the oil seals to prevent the paint from drying out the rubber, which could compromise the seal.
- We recommend machining the parts to be fitted on the gear unit output shafts with ISO H7 tolerance to avoid overly tight couplings which, during assembly, could irreparably damage the gear unit itself.

The customer is responsible for checking the coupling on the output shaft, defining suitable tolerances according to the torque to be transmitted.

- The mating surfaces must be clean and treated with suitable protective agents before assembly to prevent oxidation and consequent jamming of the parts.
- Before putting the gear unit into service, make sure that the machine incorporating it complies with the provisions of Machinery Directive 2006/42/EC and subsequent updates.
- Before starting the machine, make sure that the lubricant level is correct for the gear unit mounting position and that the viscosity is suitable for the type of application.
- If installed outdoors, provide adequate protection and/or carter to prevent direct exposure to atmospheric agents and solar radiation.



4. LUBRICATION

Please refer to the User and Maintenance Manual available at www.bonfiglioli.com for instructions on periodic oil level checks and change.

Avoid mixing mineral-based oils with synthetic oils and/or different brands.

It is good practice to check the level once a month for intermittent operation, or more frequently for continuous operation, and add oil if necessary.

4.1. SELECTION OF THE OPTIMAL OIL VISCOSITY (DATA REFERS TO SHELL OILS)

		Operating ambient temperature [C°]																				
		-40	-35	-30	-25	-20	-15	-10	-5	0	+5	+10	+15	+20	+25	+30	+35	+40	+45	+50		
		suitability seals check				standard seals provided in the catalog																
Splash lubrication	Mineral oil	150 VG							*													
		220 VG	⊖			Ⓢ			*													Ⓢ
		320 VG								*												
		460 VG									*											
Synthetic oil	150 VG				*																Ⓢ	
	220 VG	⊖			Ⓢ	*																
	320 VG					*																
Synthetic oil (PAO)	150 VG				*																Ⓢ	
	220 VG	⊖			Ⓢ	*																
	320 VG					*																
Oil	150 VG									*												
	220 VG	⊖								*											Ⓢ	
	320 VG									*												
	460 VG										*											
Synthetic oil (PAG)	150 VG							*	*												Ⓢ	
	220 VG	⊖			Ⓢ			*	*													
	320 VG							*	*													
Synthetic oil (PAO)	150 VG							*	*												Ⓢ	
	220 VG	⊖			Ⓢ			*	*													
	320 VG							*	*													

■ Recommended operating limits.

⋯ Allowed operating limits.

⊖ Forbidden operating limits.

Ⓢ If necessary, and in case of impulse loads, contact **Bonfiglioli's Technical Service**.

* = Gradual starting and higher motor absorption are recommended. If necessary and/or in the case of impulse loads, contact **Bonfiglioli's Technical Service**





4.2. LUBRICATION FOR 3/H GEAR UNITS

The internal parts of the 3/H gear unit are lubricated with an oil immersion and splash system. For output speeds below 1 rpm or input speeds above 1800 rpm consult Bonfiglioli's Technical Sales Service in advance. In the **AB6** mounting position the upper bearings are lubricated by a forced lubrication system via motor pump (MOP option), unless **Bonfiglioli's Technical Service** is consulted during selection to request a different type of lubrication.

The gear units are supplied without lubricant and it is the customer's responsibility to fill in the appropriate amount of oil before commissioning.



5. STORAGE

Correct storage of the products requires the following activities to be respected:

- Do not store outdoors, in areas exposed to the weather or with excessive humidity.
- Always place wooden or other platforms between the floor and the products to prevent direct contact with the ground.
- For long storage periods and stops, the surfaces involved in couplings such as flanges, shafts and couplings must be protected with a suitable antioxidant product (Tectile 506 EH or equivalent).

In this case, the gear units must be positioned with the vent plug in the highest position filled entirely with oil.

The correct quantity and type of lubricant must be restored to the gear units before they are put into service.

- In cases of long-term storage defined in the order with optional SLM or SLP (see specific chapter for cases and timing), the appropriate technical prescriptions can be found in the "User Manual" available at www.bonfiglioli.com. To guarantee times, conditions and extensions, contact the Bonfiglioli Service Centre available on the company website.

6. CONDITIONS OF SUPPLY

The gear units are supplied as follows:

- already prepared to be installed in the mounting position as defined in the order;
- tested according to Bonfiglioli specifications;
- with unpainted coupling surfaces;
- fitted with bolts for motor fringing (if IEC standard is specified).

7. PAINT COATING

3/H units are spray-painted with an epoxy primer coat both internally and externally, followed by external paint coating when the gear unit is finished. They meet protection class C3 (UNI EN ISO 129442) as a minimum requirement. Colour: grey, RAL 7042*.



8. SERVICE FACTOR

This is a factor that associates a numerical value with the heaviness of the application. The parameter takes into account, with some unavoidable approximations, the variability of the load under which the gear unit operates, the type of service and the duration of operation. The table provides an indication for determining the required service factor depending on the application.

Application rating in UMH (uniform, medium and high)

Required service factor f_s depending on application						
Type of load	No. of start-ups / hour Z	Total operating time (h)				
		≤ 5000	10000	15000	25000	50000
		Type of load				
		$h < 4$	$4 < h < 8$	$8 < h < 12$	$12 < h < 16$	$16 < h < 24$
Uniform	$Z < 10$	0.90	1.00	1.15	1.30	1.60
	$10 < Z < 30$	0.95	1.15	1.30	1.50	1.80
	$30 < Z < 100$	1.00	1.25	1.45	1.60	2.00
Variable with moderate shocks	$Z < 10$	1.00	1.25	1.45	1.60	2.00
	$10 < Z < 30$	1.10	1.40	1.60	1.80	2.20
	$30 < Z < 100$	1.20	1.50	1.70	2.00	2.40
Variable with strong shocks	$Z < 10$	1.20	1.50	1.70	2.00	2.40
	$10 < Z < 30$	1.30	1.60	1.80	2.10	2.60
	$30 < Z < 100$	1.40	1.75	2.00	2.30	2.80



9. SIZING

1. Determine the gear ratio:

$$i = \frac{n_1}{n_2}$$

2. Calculate the power demand P_{r1} at the gear unit's input shaft:

$$P_{r1} = \frac{M_{r2} \times n_2}{9550 \times \eta}$$

$$\eta$$

0.90

3. Determine the required service factor f_s (see paragraph 8)

$$P_{n1} \geq P_{r1} \times f_s$$

4. By referring to the technical data tables, select the gear unit with the closest gear ratio to the calculated one and characterised by a rated power P_{n1} such that:



the sizing method is valid for applications using an electric motor.

If the gear unit is to be driven by other types of motor, contact **Bonfiglioli's Technical Service**.



GEAR UNIT SELECTION

General Data

Company / Customer:	Order quantity:
Contact:	Delivery time:
Branch / Distributor:	Type of application:

Gearbox Data

Gearbox configuration:	
i Gear ratio:	Rotation of the output shaft: CW CCW
n ₂ Output speed: [min ⁻¹]	L _{10H} Bearings lifetime: [h]
Mr ₂ Output torque demand: [Nm]	Gears lifetime: [h]
Mp ₂ Output peak torque demand: [Nm]	SF _{min} Safety for tooth root stress: [ISO preferred]
Sf Service factor demand:	SH _{min} Safety for flank pressure: [ISO preferred]

Electric Motor

Motor Type:	
P _{n1} Rated motor Power: [kW]	Pole number
P _{r1} Motor power demand: [kW]	Motor mounting: B3 B5 B14
n ₁ Input speed [min ⁻¹]	Motor weight: [Kg]

Additional Loads

R _{c1} Radial load on input shaft: [N]	A Radial load on input shaft [mm]
P _{r1} Load app. distance from shaft shoulder [mm]	C Load app. distance from shaft shoulder [mm]
A _{n1} Thrust load on input shaft (+ / -) [N]	

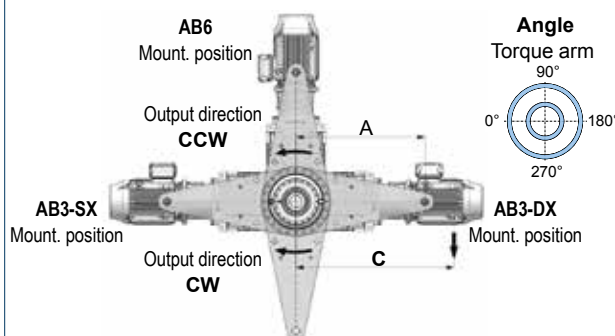
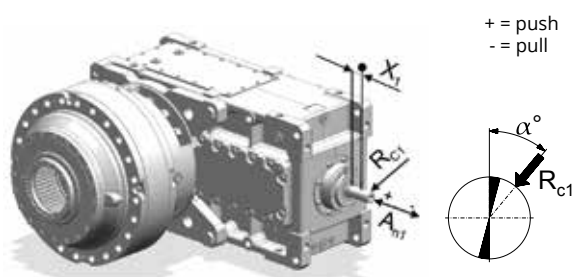

Mounting position:	Output Direction:	Angle:°
--------------------------	-------------------------	---------------

Application

Duty cycle	Time phase %	Time phase hours	Gb. output torque [Nm]	Gb. output speed [min ⁻¹]

Ambient temperature range	S1:	S2:	S3:	S4-S8:
---------------------------	-----------	-----------	-----------	--------------

V _A Ambient air velocity ≤ 0.5 > 0.5 ≤ 1.4 > 1.4 [m/s]	Altitude a.s.l [m]
---	--------------------

T _{AMB} Ambient temperature range [°C]	Rating according FEM class T- L- M-
---	---

Options or additional requests

Lubrication:	Paint coating:
Supplementary cooling systems:	To specific requests for testing:

Note and Utility

Notes and additional Customer requirements

The following form is designed to support product sizing. For the best results, we strongly recommend relying on the experience and specialized expertise of **Bonfiglioli's Technical Service**. The ideal transmission solution can only be identified with a complete understanding of both the functional and environmental conditions of the application.





10. VERIFICATION

10.1 MOTOR AVAILABILITY

For the selected gear unit, check the availability of the relevant coupling flange in section 15.

The typical standardisation of electric motors may lead to selecting a motor with a power rating even much higher than the rated power Pn1 of the gear unit you have sized. Check that the maximum power that can be delivered by the electric motor is not reached under any conditions during the work cycle. In the event of uncertain calculation data or doubts about the actual load diagram of the application, it is advisable to install a torque limiting device.

10.2 BACKSTOP DEVICE

If the gear unit is provided with a backstop device, check its load capacity in the relevant sections 16.3 of this catalogue and ensure that the maximum input torque value of the M1MAX gear unit is never exceeded during its operation.

10.3 RADIAL LOAD BEARING CAPACITY CHECK

Transmission components keyed onto the gear unit input shafts generate forces, the resultant of which acts radially on the shaft itself.

The magnitude of these loads must be compatible with the bearing capacity of the shaft-bearing system of the gear unit. In particular, the absolute value of the applied load (Rc for the input shaft) must be lower than the nominal value (Rx for the input shaft) shown in the technical data tables.

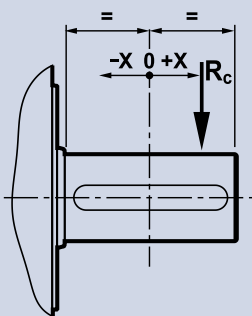

$$R_x = R_n \times K$$
$$R_c \leq R_x$$

$$R_c = \frac{2000 \times M \times K_r}{d}$$

$K_r = 1$		M [Nm]	
$K_r = 1.25$		d [mm]	
$K_r = 1.5 - 2.0$			

The $R_{n_{max}}$ values provided in this table are the maximum admissible radial loads; they may be subject to limitations depending on the application conditions.

For a precise calculation please contact **Bonfiglioli's Technical Service**.





	i =	R _{n max} [kN]	K ₁												
			x [mm] =												
			-100	-75	-50	-25	0	25	50	75	100	150	200	250	300
3/H 11L2	30.3 ... 65.0	17.9	—	—	2.37	1.41	1.00	0.78	0.64	0.54	0.46	—	—	—	—
3/H 11L2	76.0 ... 270.3	11.6	—	—	2.17	1.37	1.00	0.79	0.65	0.52	0.43	—	—	—	—
3/H 11L2	355.4...1099	5.9	—	—	—	1.54	1.00	0.75	0.53	0.42	0.34	—	—	—	—
3/H 13L2	30.6 ... 65.8	17.9	—	—	2.37	1.41	1.00	0.78	0.64	0.54	0.46	—	—	—	—
3/H 13L2	77.0 ... 273.7	11.6	—	—	2.17	1.37	1.00	0.79	0.65	0.52	0.43	—	—	—	—
3/H 13L2	339.5...1113	5.9	—	—	—	1.54	1.00	0.75	0.53	0.42	0.34	—	—	—	—
3/H 15L2	93.5 ... 1039	10.8	—	—	2.23	1.38	1.00	0.78	0.63	0.51	0.43	0.32	—	—	—
3/H 15L2	329.0...517.2	7.2	—	—	—	1.56	1.00	0.72	0.52	0.40	0.33	—	—	—	—
3/H 15L2	582.7...1039	4.8	—	—	—	1.56	1.00	0.74	0.58	0.46	0.38	—	—	—	—
3/H 15L3	128.8...354.6	17.9	—	—	2.37	1.41	1.00	0.78	0.64	0.54	0.46	—	—	—	—
3/H 15L3	414.8 ...1160	11.6	—	—	2.17	1.37	1.00	0.75	0.53	0.42	0.34	—	—	—	—
3/H 16L2	111,4	18.7	—	—	2.23	1.38	1.00	0.78	0.64	0.54	0.45	0.34	—	—	—
3/H 16L2	117.3...413.1	10.8	—	—	2.23	1.38	1.00	0.78	0.63	0.51	0.43	0.32	—	—	—
3/H 16L2	456.8...648.7	7.2	—	—	—	1.56	1.00	0.72	0.52	0.40	0.33	—	—	—	—
3/H 16L2	730.7...1150	4.8	—	—	—	1.56	1.00	0.74	0.58	0.46	0.38	—	—	—	—
3/H 16L3	128.8...354.6	17.9	—	—	2.37	1.41	1.00	0.78	0.64	0.54	0.46	—	—	—	—
3/H 16L3	414.8 ...1160	11.6	—	—	2.17	1.37	1.00	0.75	0.53	0.42	0.34	—	—	—	—
3/H 17L2	102.4...129.2	18.7	—	—	2.23	1.38	1.00	0.78	0.64	0.54	0.45	0.34	—	—	—
3/H 17L2	148.6...412.7	10.8	—	—	2.23	1.38	1.00	0.78	0.63	0.51	0.43	0.32	—	—	—
3/H 17L2	456.8...851.6	7.2	—	—	—	1.56	1.00	0.72	0.52	0.40	0.33	—	—	—	—
3/H 17L2	943.4	4.8	—	—	—	1.56	1.00	0.74	0.58	0.46	0.38	—	—	—	—
3/H 17L3	125.6...268.0	17.9	—	—	2.37	1.41	1.00	0.78	0.64	0.54	0.46	—	—	—	—
3/H 17L3	314.1...921.1	11.6	—	—	2.17	1.37	1.00	0.75	0.53	0.42	0.34	—	—	—	—
3/H 18L2	99.4...295.2	22.6	—	—	1.82	1.29	1.00	0.78	0.62	0.51	0.44	0.34	0.28	—	—
3/H 18L2	314.6...964.0	10.9	—	—	2.25	1.38	1.00	0.78	0.63	0.50	0.42	0.32	—	—	—
3/H 18L3	119.7...364.3	19.4	—	—	1.88	1.30	1.00	0.81	0.68	0.59	0.51	0.40	0.32	—	—
3/H 18L3	444.2...578.1	18.7	—	—	2.23	1.38	1.00	0.78	0.64	0.54	0.45	0.34	—	—	—
3/H 18L3	639.2...1128	10.8	—	—	2.23	1.38	1.00	0.78	0.63	0.51	0.43	0.32	—	—	—
3/H 19L2	105.6...387.2	22.6	—	—	1.82	1.29	1.00	0.78	0.62	0.51	0.44	0.34	0.28	—	—
3/H 19L2	412.6...1098	10.9	—	—	2.25	1.38	1.00	0.78	0.63	0.50	0.42	0.32	—	—	—
3/H 19L3	132.5...320.9	19.4	—	—	1.88	1.30	1.00	0.81	0.68	0.59	0.51	0.40	0.32	—	—
3/H 19L3	391.2...432.6	18.7	—	—	2.23	1.38	1.00	0.78	0.64	0.54	0.45	0.34	—	—	—
3/H 19L3	455.4...993.6	10.8	—	—	2.23	1.38	1.00	0.78	0.63	0.51	0.43	0.32	—	—	—
3/H 21L3	120.1...361.2	22.6	—	—	1.82	1.29	1.00	0.78	0.62	0.51	0.44	0.34	0.28	—	—
3/H 21L3	403.1...573.2	18.7	—	—	2.23	1.38	1.00	0.78	0.64	0.54	0.45	0.34	—	—	—
3/H 21L3	659.4...960.0	10.8	—	—	2.23	1.38	1.00	0.78	0.63	0.51	0.43	0.32	—	—	—
3/H 23L3	121.5...266.6	35.8	—	2.21	1.57	1.22	1.00	0.85	0.73	0.62	0.54	0.42	0.35	0.30	—
3/H 23L3	297.9...936.9	22.6	—	—	1.82	1.29	1.00	0.78	0.62	0.51	0.44	0.34	0.28	—	—
3/H 25L3	127.7...304.6	35.8	—	2.21	1.57	1.22	1.00	0.85	0.73	0.62	0.54	0.42	0.35	0.30	—
3/H 25L3	340.5...1071	22.6	—	—	1.82	1.29	1.00	0.78	0.62	0.51	0.44	0.34	0.28	—	—



10.4 RADIAL AND AXIAL LOADS ON INPUT SHAFT

To check radial load bearing capacity refer to the diagram in paragraph 10.3 and compare the **Rc** radial force acting on the shaft with the admissible **Rx** load corresponding to the distance of application of the force itself from the midpoint of the shaft. The **Rx₁** admissible load for the input shaft is obtained by multiplying the **Rn₁** nominal value, which can be found in the technical data tables, by the **K₁** displacement coefficient. The **Rn** permissible overhung loads relate to the most unfavourable calculation conditions based on the direction of rotation and angle of force application, and therefore represent a conservative value.

For a precise calculation please consult **Bonfiglioli's Technical Service**. In addition to the radial load, an axial load **An₁**, $\leq 0.2 \times Rn1$ is applicable.

10.5 THERMAL POWER

Thermal power is the maximum power that can be mechanically transmitted by the gear unit, in continuous operation, without the internal temperature reaching a value that could damage the gear unit components.

The **PTB** and **PT_{FAN}** are calculated considering the following operating conditions:

- Input speed of 1800/1500 rpm
- Ambient temperature 20/40°C
- Horizontal mounting position AB3
- Installation in large open spaces (air velocity > 1.4 m/s)
- Continuous operation
- Maximum installation altitude 1000 m
- ISO VG 220 oil

Performance data valid for a specific size and gear ratio.

Contact **Bonfiglioli's Technical Service** for information regarding other operating conditions.

The basic thermal capacity must be greater than (or equal to) input power consumption (**Pr1**).

$$P_{TB} \geq Pr_1$$

In cases where the **PTB < Pr1**, the gear units can be equipped with auxiliary cooling systems. The basic **PTB** and the **FAN** thermal capacities are given in chapter 17, while for the selection of the **MCRW** or **MCRA** thermal auxiliary device, refer to chapter 16.1.3.

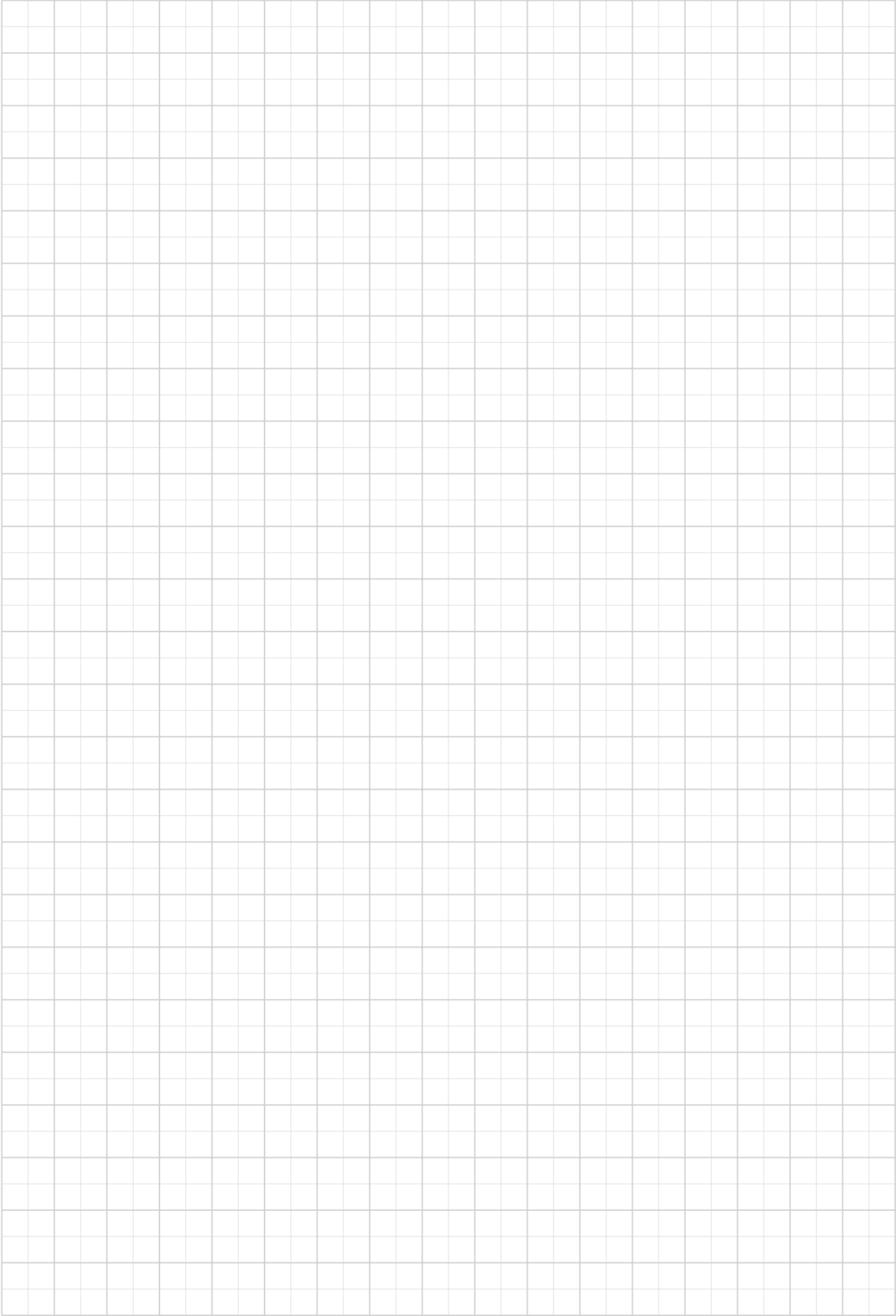

3/H series gear unit



11. DESIGN FEATURES

The main design features of the 3/H series are:

- 10 sizes: 11, 13, 15, 16, 17, 18, 19, 21, 23, 25
- Rated torque values with favourable distribution over the entire ratio range.
- Alloy steel bevel and cylindrical gears, case-hardened, hardened and ground, with profile correction to:
 - reduce noise and promote smooth transmission of fast gears;
 - maximise transmissible torque of final drives.
- Generally case-hardened and ground input shafts.
- Input shaft ends according to UNI/ISO 77588. Motor adapter by means of connection bell and flexible coupling.
- Several possibilities for customising the gear unit via options on request, including:
 - backstop device;
 - seals and gaskets of different types and materials;
 - sensors;
 - fixing elements;
 - auxiliary thermal cooling/heating devices;
 - forced lubrication systems.

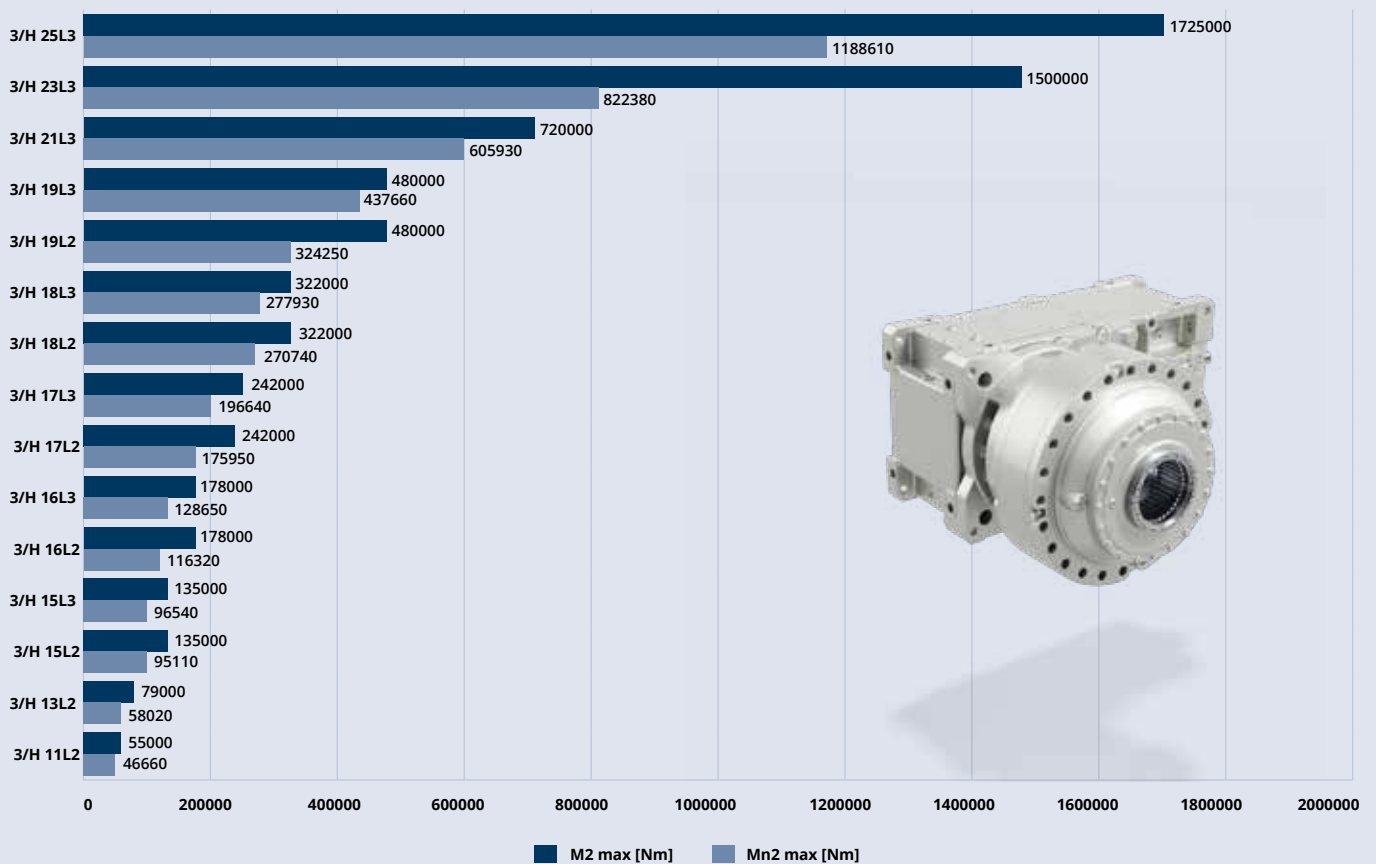

M_{n2max} = maximum continuously transmissible torque

M_{2max} = torque that can be borne by the gear unit under static or quasi-static conditions. The value may vary depending on the output configuration



12. PRODUCT CONFIGURATIONS

12.1 BASIC VARIANTS

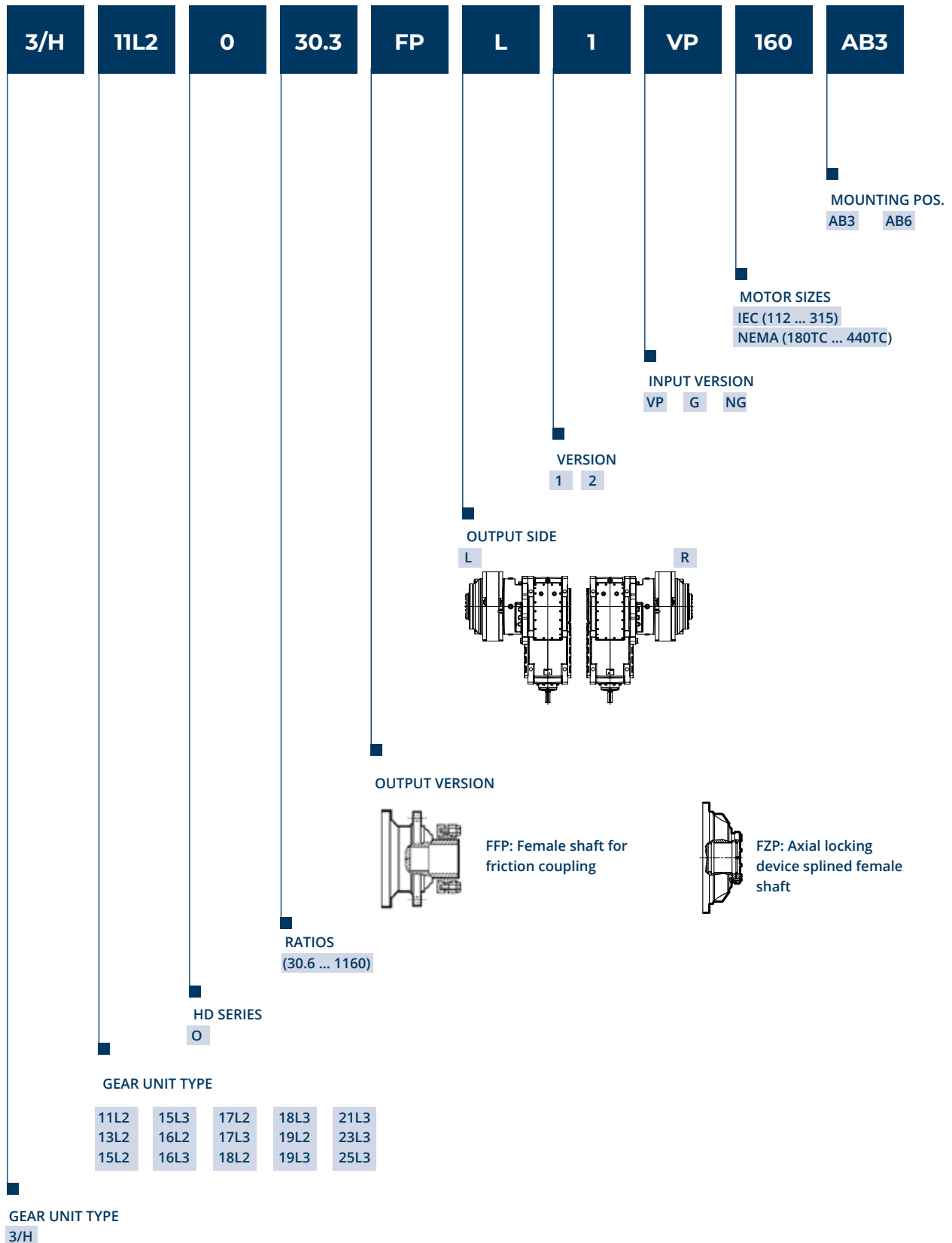

12.3 MOUNTING POSITION



NOTE: Gear units in AB6 mounting position are always supplied with forced lubrication system (MOP, MCRW, MCRA). For overall dimensions refer to paragraph 16.1.

13. INPUT AND OUTPUT CONFIGURATION

13.1 OUTPUT SHAFT CONFIGURATION

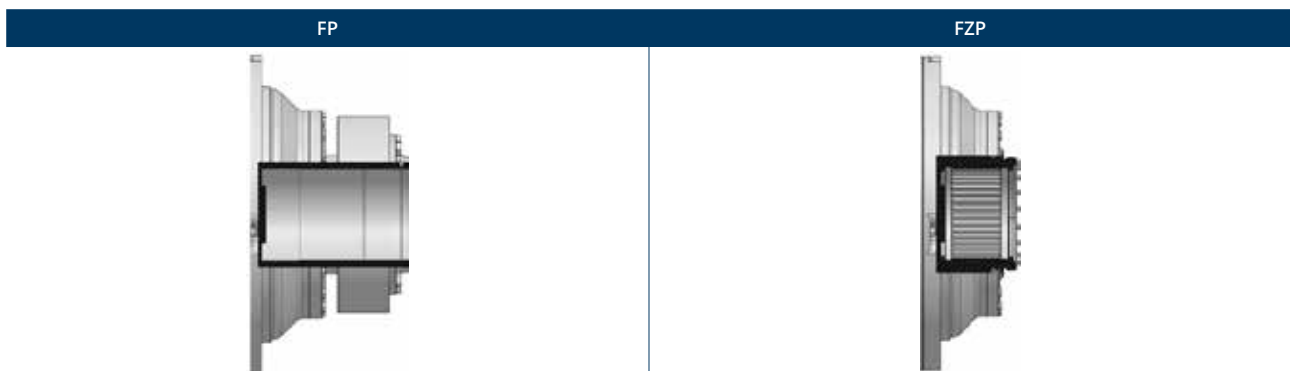

FP: Female shaft with friction joint always supplied

FZP: Axial locking device splined female shaft

13.2 INPUT SHAFT CONFIGURATION

Possible input configurations are:

- Cylindrical shaft with VP variant
- IEC motor flange with G variant
- NEMA motor flange with NG variant

G and NG variants include provision of the flexible coupling

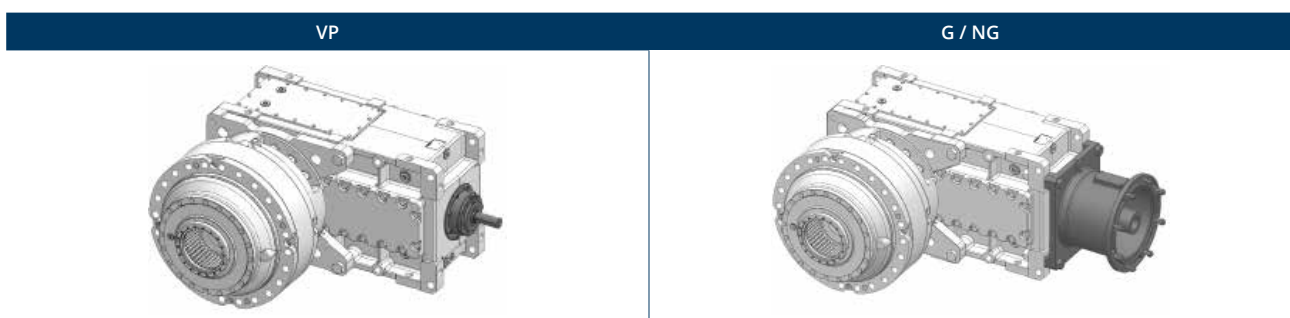

14. OUTPUT SHAFT ARRANGEMENT

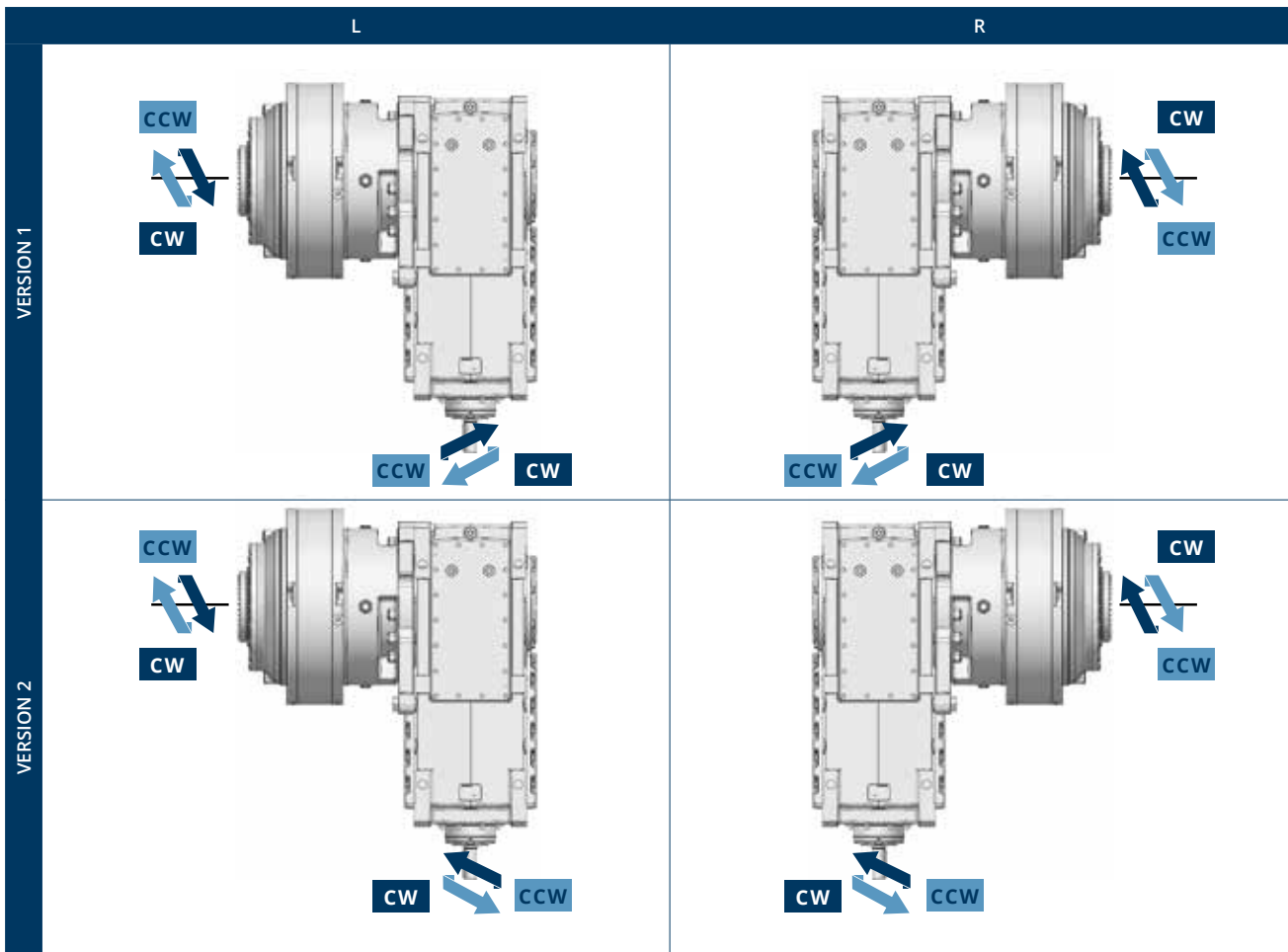

15. MOTOR ADAPTER

The following tables show the possible motor/gear unit availability.

The motor adapter is defined in the configuration with the nomenclature G coupling by means of flexible coupling and IEC motor housing, NG coupling by means of a flexible coupling and NEMA motor housing.



If the motor power output exceeds the Pn1 rated power of the gear unit during selection, we recommend installing a torque limiter or contacting **Bonfiglioli's Technical Service**.



	Fast configuration								
	G								
	112	132	160	180	200	225	250	280	315
3/H 11L2	651.5 1099	335.4 1099	150.9 1099	98.6 560.7	65.0 335.4	36.8 248.3	30.3 164.4	30.3 125.2	-
3/H 13L2	838.4 1113	339.5 1113	166.4 1113	120.5 659.5	77.0 394.5	42.6 273.7	37.3 177.6	30.6 152.8	-
3/H 15L2	-	657.5 1039	329.0 1039	204.0 1039	145.8 517.2	93.5 517.2	93.5 286.9	93.5 259.3	93.5 185.3
3/H 15L3	-	-	414.8 1160	414.8 956.7	156.6 537.4	128.8 537.4	128.8 325.6	128.8 217.5	-
3/H 16L2	-	824.6 1150	359.8 1150	232.4 1150	164.7 648.7	131.1 648.7	131.1 413.1	111.4 283.0	111.4 182.8
3/H 16L3	-	-	414.8 1160	414.8 1160	200.1 956.7	144.4 682.4	128.8 501.8	128.8 354.6	-
3/H 17L2	-	-	456.8 943.4	456.8 943.4	236.3 851.6	148.6 851.6	148.6 412.7	102.4 412.7	102.4 283.5
3/H 17L3	-	-	678.9 921.1	492.6 921.1	314.1 921.1	173.8 921.1	152.2 725.1	125.6 516.6	-
3/H 18L2	-	-	964.0	621.7 964.0	388.1 964.0	314.6 964.0	192.7 964.0	124.5 766.9	99.4 295.2
3/H 18L3	-	-	923.6 1128	578.1 1128	517.0 1128	517.0 1128	517.0 1128	130.9 806.1	119.7 491.2
3/H 19L2	-	-	1098	700.5 1098	508.9 1098	412.6 1098	252.7 1098	142.5 890.3	105.6 387.2
3/H 19L3	-	-	-	993.6	710.0 993.6	455.4 993.6	455.4 993.6	144.9 993.6	132.5 710.0
3/H 21L3	-	-	-	-	-	659.4 960.0	659.4 960.0	403.1 960.0	120.1 960.0
3/H 23L3	-	-	-	-	-	-	750.7 936.9	484.1 936.9	172.5 936.9
3/H 25L3	-	-	-	-	-	-	981.1 1071	633.9 1071	197.1 1071





	Fast configuration							
	NG							
	N180TC	N210TC	N250TC	N280TC	N320TC	N360TC	N400TC	N440TC
3/H 11L2	828.2 1099	373.4 1099	164.4 921.9	119.0 560.7	59.7 335.4	33.9 175.5	30.3 125.2	-
3/H 13L2	933.2 1113	488.9 1113	215.3 1113	152.8 659.5	77.0 394.5	42.6 251.3	30.6 152.8	-
3/H 15L2	-	827.5 1039	411.0 1039	259.3 1039	131.3 657.5	93.5 462.8	93.5 259.3	-
3/H 15L3	-	-	414.8 1160	414.8 896.5	128.8 537.4	128.8 354.6	128.8 217.5	-
3/H 16L2	-	929.0 1150	413.1 1150	283.0 1150	164.7 824.6	111.4 515.4	111.4 283.0	-
3/H 16L3	-	-	501.8 1160	414.8 1160	200.1 956.7	128.8 537.4	128.8 354.6	-
3/H 17L2	-	-	540.8 943.4	456.8 943.4	236.3 943.4	129.2 718.7	102.4 412.7	102.4 283.5
3/H 17L3	-	-	878.6 921.1	623.9 921.1	314.1 921.1	173.8 921.1	125.6 516.6	-
3/H 18L2	-	-	-	678.9 964.0	388.1 964.0	237.6 964.0	168.5 766.9	99.4 295.2
3/H 18L3	-	-	1128	726.2 1128	444.2 1128	444.2 1128	187.0 806.1	-
3/H 19L2	-	-	-	890.3 1098	450.6 1098	311.6 1098	221.0 890.3	105.6 387.2
3/H 19L3	-	-	-	993.6	509.2 993.6	391.2 993.6	207.0 993.6	-
3/H 21L3	-	-	-	-	960.0	507.9 960.0	403.1 960.0	131.0 960.0
3/H 23L3	-	-	-	-	-	936.9	684.0 936.9	297.9 936.9
3/H 25L3	-	-	-	-	-	981.1 1071	781.8 1071	304.6 1071

16 OPTIONAL VARIANTS

16.1 AUXILIARY THERMAL DEVICES

16.1.1 FORCED VENTILATION

Increased heat dissipation capacity can be achieved using a cooling fan splined to the gear unit's input shaft. It is possible to specify the provision of a fan on the coplanar shaft using the FAN option. For sizes 3/H 11L2, 13L2, 15L3, 16L3, 17L3 the FAN option of forced ventilation is not compatible with the TK option of sealing with Taconite at the gear unit input.

The forced ventilation efficiency is greatly reduced for intermittent operation and drive speeds below $n_1 = 900 \text{ min}^{-1}$. In this case, it is advisable to use other auxiliary cooling systems to increase the thermal power of the gear unit.

FAN

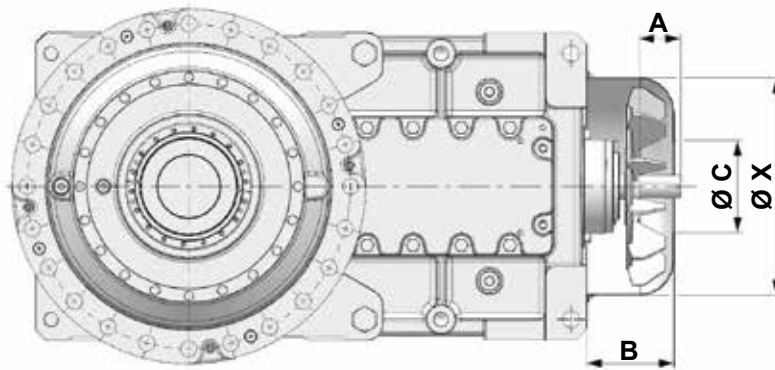

	i =	A [mm]	B [mm]	C [mm]	X [mm]
3/H 11L2	30.3 - 65.0	82	210	140	425
3/H 11L2	76.0 - 270.3	82	210	140	425
3/H 11L2	355.4 - 1099	58	210	140	425
3/H 13L2	30.6 - 65.8	82	210	140	425
3/H 13L2	77.0 - 273.7	82	210	140	425
3/H 13L2	339.5 - 1113	58	210	140	425
3/H 15L2	93.5 - 1039	82	207	180	425
3/H 15L2	329.0 - 1039	58	207	180	425
3/H 15L3	128.8 - 354.6	82	210	140	425
3/H 15L3	414.8 - 1160	82	210	140	425
3/H 16L2	111.4 - 413.1	82	207	180	425
3/H 16L2	456.8 - 1150	58	207	180	425
3/H 16L3	128.8 - 354.6	82	210	140	425
3/H 16L3	414.8 - 1160	82	210	140	425
3/H 17L2	102.4 - 412.7	82	172	180	425
3/H 17L2	456.8 - 943.4	58	172	180	425

	i =	AB3	A [mm]	B [mm]	C [mm]
3/H 17L3	125.6 - 268.0	82	210	140	425
3/H 17L3	314.1 - 921.1	82	210	140	425
3/H 18L2	99.4 - 295.2	105	222	230	534
3/H 18L2	314.6 - 964.0	82	287.5	230	425
3/H 18L3	119.7 - 364.3	105	207	180	425
3/H 18L3	444.2 - 1128	82	207	180	425
3/H 19L2	105.6 - 387.2	105	222	230	534
3/H 19L2	412.6 - 1098	82	287.5	230	425
3/H 19L3	132.5 - 320.9	105	207	180	425
3/H 19L3	391.2 - 993.6	82	207	180	425
3/H 21L3	120.1 - 361.2	105	232	180	425
3/H 21L3	403.1 - 960.0	82	172	180	425
3/H 23L3	121.5 - 266.6	140	327.5	230	534
3/H 23L3	297.9 - 936.9	105	222	230	534
3/H 25L3	127.7 - 304.6	140	327.5	230	534
3/H 25L3	340.5 - 1071	105	222	230	534

16.1.2 HEAT DISSIPATION THROUGH COOLING COIL

The exchange coil – SR option – is designed to be integrated in a cooling circuit, the construction of which is the responsibility of the installer and is only available for mounting position AB3, see paragraph 12.3.

For optimum performance, the supply circuit must meet the following specifications:

- max. pressure 8 bar
- min. flow rate 5 l/min for 3/H 11L2, 13L2, 15L3, 16L3, 17L3
- min. flow rate 10 l/min for 3/H 15L2, 16L2, 18L2, 19L3, 17L2, 21L3, 18L3, 19L2, 23L3, 25L3
- max. water temperature 20°C

SR

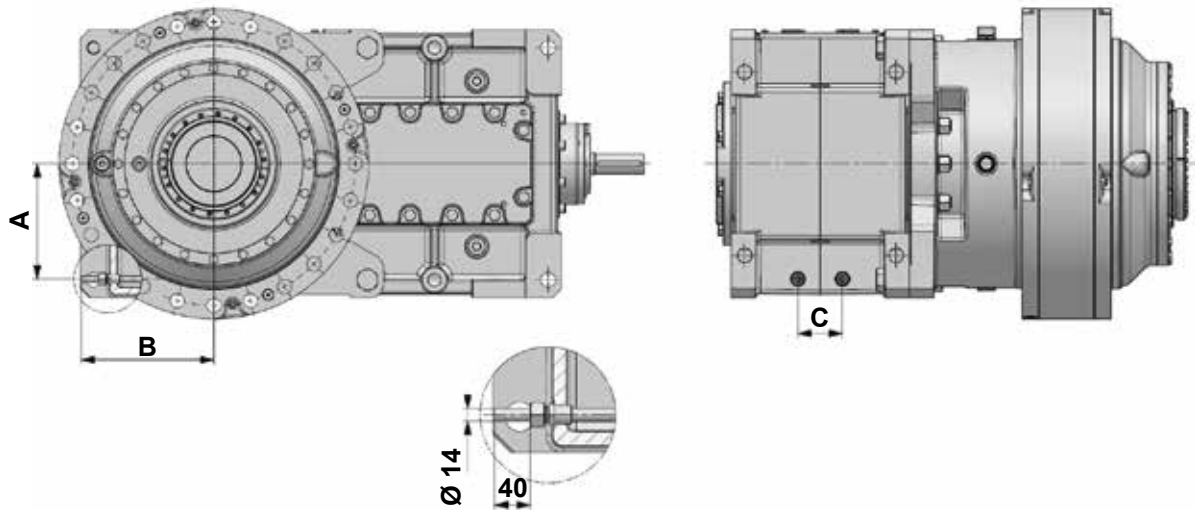

AB3	A [mm]	B [mm]	C [mm]
3/H 11L2	190	210	60
3/H 13L2			
3/H 15L3			
3/H 16L3			
3/H 17L3			

AB3	A [mm]	B [mm]	C [mm]
3/H 17L2	258	305	100
3/H 21L3			

AB3	A [mm]	B [mm]	C [mm]
3/H 15L2	230	270	100
3/H 16L2			
3/H 18L3			
3/H 19L3			

AB3	A [mm]	B [mm]	C [mm]
3/H 18L2	325	340	100
3/H 19L2			
3/H 23L3			
3/H 25L3			

16.1.3 AUXILIARY COOLING WITH AUTONOMOUS COOLING UNIT

Two types of control units are offered as options, each in several sizes corresponding to different cooling capacities, using a different oil cooling medium,

MCRW... – with water/oil cooler and **MCRA...** – with air/oil cooler.

When using an autonomous cooling unit, subject to verification by the Bonfiglioli Technical Service, it is not necessary to specify an additional forced lubrication device, see paragraph 16.1.

The availability of the device is shown in the table below for each gear unit size depending on the mounting position since for position AB6, see paragraph 12.3, the exchanger is supplied with a fixed size.

To estimate the excess P_s power use the following formula:

$$P_s = \alpha_T \times (P_{r1} - P_T)$$

The α_T coefficient depending on the size and ratio is given in the table below

AB3	i =	α_T	MCRW MCRA 5	MCRW MCRA 9	MCRW MCRA 21	MCRW MCRA 34
3/H 11L2	30.3 65.0	0.03	✓	✓	–	–
3/H 11L2	76.0 270.3	0.05	✓	✓	–	–
3/H 11L2	355.4 1099	0.08	✓	✓	–	–
3/H 13L2	30.6 65.8	0.03	✓	✓	–	–
3/H 13L2	77.0 273.7	0.05	✓	✓	–	–
3/H 13L2	339.5 1113	0.08	✓	✓	–	–
3/H 15L2	93.5 1039	0.05	✓	✓	–	–
3/H 15L2	329.0 1039	0.08	✓	✓	–	–
3/H 15L3	128.8 354.6	0.03	✓	✓	–	–
3/H 15L3	414.8 1160	0.05	✓	✓	–	–
3/H 16L2	111.4 413.1	0.05	✓	✓	–	–
3/H 16L2	456.8 1150	0.08	✓	✓	–	–
3/H 16L3	128.8 354.6	0.03	✓	✓	–	–
3/H 16L3	414.8 1160	0.05	✓	✓	–	–
3/H 17L2	102.4 412.7	0.05	✓	✓	✓	–
3/H 17L2	456.8 943.4	0.08	✓	✓	✓	–

AB3	i =	α_T	MCRW MCRA 5	MCRW MCRA 9	MCRW MCRA 21	MCRW MCRA 34
3/H 17L3	125.6 268.0	0.03	✓	✓	–	–
3/H 17L3	314.1 921.1	0.05	✓	✓	–	–
3/H 18L2	99.4 295.2	0.05	✓	✓	✓	✓
3/H 18L2	314.6 964.0	0.08	✓	✓	✓	✓
3/H 18L3	119.7 364.3	0.03	✓	✓	–	–
3/H 18L3	444.2 1128	0.05	✓	✓	–	–
3/H 19L2	105.6 387.2	0.05	✓	✓	✓	✓
3/H 19L2	412.6 1098	0.08	✓	✓	✓	✓
3/H 19L3	132.5 320.9	0.03	✓	✓	–	–
3/H 19L3	391.2 993.6	0.05	✓	✓	–	–
3/H 21L3	120.1 361.2	0.03	✓	✓	–	–
3/H 21L3	403.1 960.0	0.05	✓	✓	✓	–
3/H 23L3	121.5 266.6	0.03	✓	✓	✓	–
3/H 23L3	297.9 936.9	0.05	✓	✓	✓	✓
3/H 25L3	127.7 304.6	0.03	✓	✓	✓	–
3/H 25L3	340.5 1071	0.05	✓	✓	✓	✓

For the availability of exchangers of different sizes, contact **Bonfiglioli's Technical Service**.

The following table shows the exchange power values of MCRW control units with water at 20°C.

P_{S_MCRW} [kW]

MCRW 5	MCRW 9	MCRW 21	MCRW 34
3.5	8.1	14.1	19.6

The following table shows the exchange power values of MCRA control units based on the ambient temperature.

P_{S_MCRA} [kW]

T_{amb} [°C]	MCRA 5	MCRA 9	MCRA 21	MCRA 34
20	5.6	7.5	16	21.6
40	3.4	4.5	9.6	13

Application cases

Example 1

3/H 15 L3 179.2

Application data:

$n_1 = 1500$ rpm

Mounting position = AB3 Ambient temperature = 40°C $P_{n1} = 76$ Kw

Thermal power verification $PT = 57$ kW < $P_{n1} = 76$ kW



FAN option



$PT_{FAN} = 108$ kW > $P_{n1} = 76$ kW

Example 2

3/H 21 L3 258.6

Application data:

$n_1 = 1500$ rpm

Mounting position = AB3 Ambient temperature = 40°C $P_{n1} = 275$ Kw

Thermal power verification

$PT = 130$ kW < $P_{n1} = 275$ kW



FAN option



$PT_{FAN} = 220$ kW < $P_{n1} = 275$ kW

MCRW / MCRA option - αT coefficient

$\alpha T = 0.03$

Power to be dissipated

$P_s = 0.03 \times (275 - 130) \cong 4.3$ kW

Suitable cooling device MCRW 9 - MCRA 9



Control unit main components: MCRW...

1) Motor pump with motor by-pass circuit (230/400-50, 230/265/460-60)

2) Filter with visual clogging indicator

3) Water/oil heat exchanger

4) Minimum pressure switch

(only present in case of forced lubrication)

5) Maximum temperature thermostat

6) Insertion thermostat

7) Solenoid valve

Power supply (230-50, 240-60)

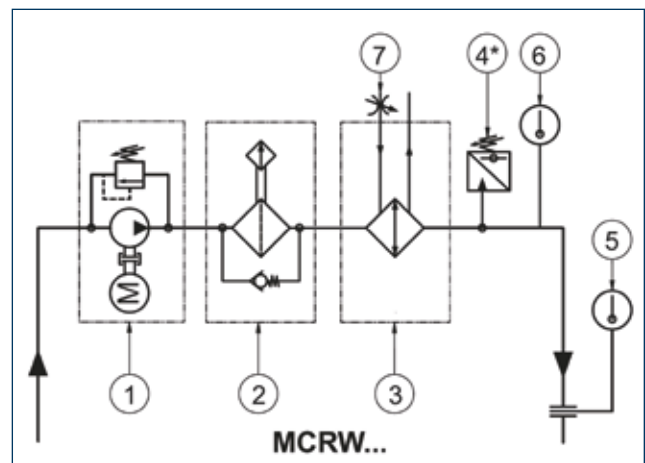

MCRA...

- 1) Motor pump with motor by-pass circuit (230/400-50, 230/265/460-60)
- 2) Filter with visual clogging indicator
- 3) Air/oil heat exchanger with thermostat
- 4) Minimum pressure switch (only present in case of forced lubrication)
- 5) Maximum temperature thermostat

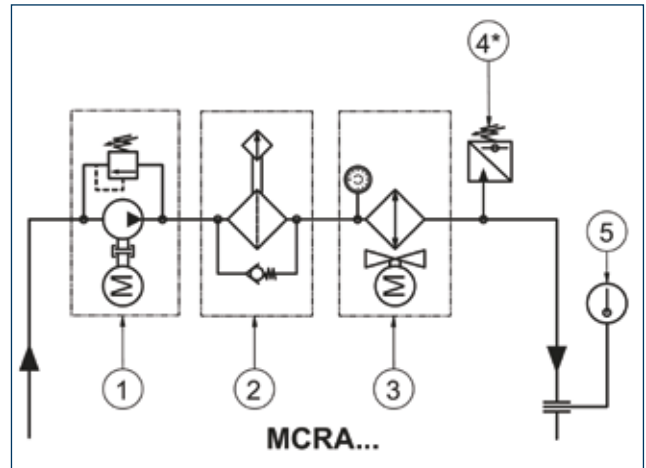

For different supply voltages please contact **Bonfiglioli's Technical Service**.

General warnings:

MCRW... : provide a water supply circuit that meets the following specifications:

- max. pressure 10 bar
- max. flow temperature 20°C
- minimum flow rate Q H₂O according to table:

	MCRW 5	MCRW 9	MCRW 21	MCRW 34
Q _{H₂O} [l/min]	3.5	8.1	14.1	19.6

MCRW

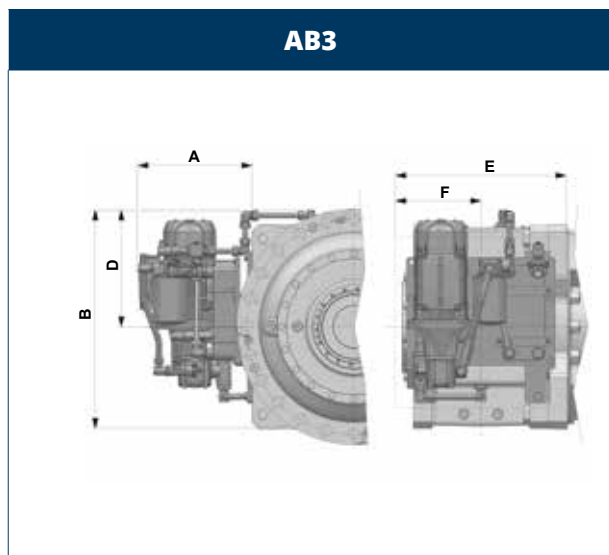

MCRW 5	A [mm]	B [mm]	D [mm]	E [mm]	F [mm]
	360	480	255	480	240

MCRW 9	A [mm]	B [mm]	D [mm]	E [mm]	F [mm]
	360	540	300	480	240

MCRW 21	A [mm]	B [mm]	D [mm]	E [mm]	F [mm]
	380	600	300	460	230

MCRW 34	A [mm]	B [mm]	D [mm]	E [mm]	F [mm]
	430	650	465	1000	500



The maximum overall dimensions A, B, C, D, E and F are approximate.



AB6

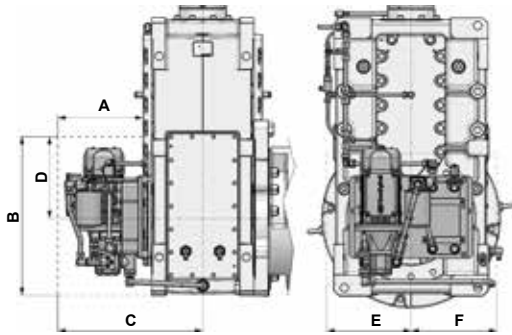

MCRW 5	A [mm]	B [mm]	C [mm]	D [mm]	E [mm]	F [mm]
3/H 11L2						
3/H 13L2						
3/H 15L3	340	430	520	190	275	225
3/H 16L3						
3/H 17L3						

MCRW 9	A [mm]	B [mm]	C [mm]	D [mm]	E [mm]	F [mm]
3/H 17L2	360	540	620	300	240	240
3/H 21L3						

MCRW 9	A [mm]	B [mm]	C [mm]	D [mm]	E [mm]	F [mm]
3/H 15L2						
3/H 16L2	445	660	630	405	340	315
3/H 18L3						
3/H 19L3						

MCRW 21	A [mm]	B [mm]	C [mm]	D [mm]	E [mm]	F [mm]
3/H 18L2						
3/H 19L2	445	600	730	245	360	360
3/H 23L3						
3/H 25L3						

MCRA

AB3

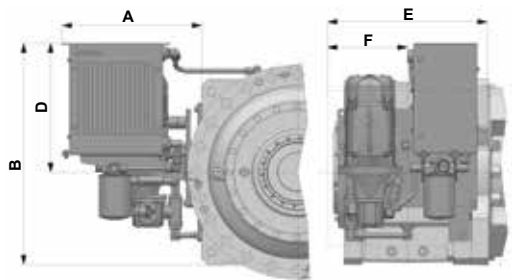

MCRA 5	A [mm]	B [mm]	D [mm]	E [mm]	F [mm]
	365	575	330	380	190

MCRA 9	A [mm]	B [mm]	D [mm]	E [mm]	F [mm]
	420	630	370	480	240

MCRA 21	A [mm]	B [mm]	D [mm]	E [mm]	F [mm]
	715	760	380	720	360

MCRA 34	A [mm]	B [mm]	D [mm]	E [mm]	F [mm]
	500	920	735	840	420

AB6

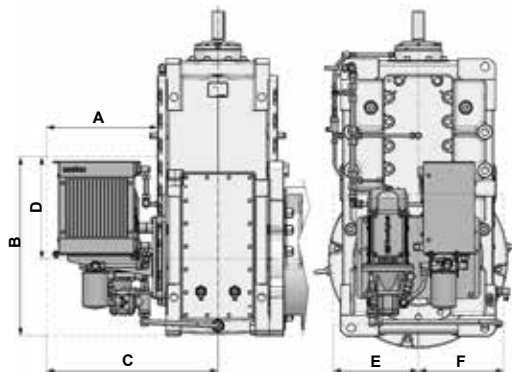

MCRA 5	A [mm]	B [mm]	C [mm]	D [mm]	E [mm]	F [mm]
3/H 11L2						
3/H 13L2						
3/H 15L3	365	575	605	330	275	310
3/H 16L3						
3/H 17L3						

MCRA 9	A [mm]	B [mm]	C [mm]	D [mm]	E [mm]	F [mm]
3/H 17L2	420	630	720	280	480	280
3/H 21L3						

MCRA 9	A [mm]	B [mm]	C [mm]	D [mm]	E [mm]	F [mm]
3/H 15L2						
3/H 16L2	365	575	580	330	275	310
3/H 18L3						
3/H 19L3						

MCRA 21	A [mm]	B [mm]	C [mm]	D [mm]	E [mm]	F [mm]
3/H 18L2						
3/H 19L2	720	715	1005	380	360	360
3/H 23L3						
3/H 25L3						



The maximum overall dimensions A, B, C, D, E and F are approximate.



16.1.4 FORCED MOTOR PUMP LUBRICATION

3/H gear units in mounting position AB6 are supplied with the bearings not immersed in oil lubricated via an independently powered forced lubrication circuit - MOP option. The forced lubrication devices can be replaced by the MCR autonomous cooling units...

MOP

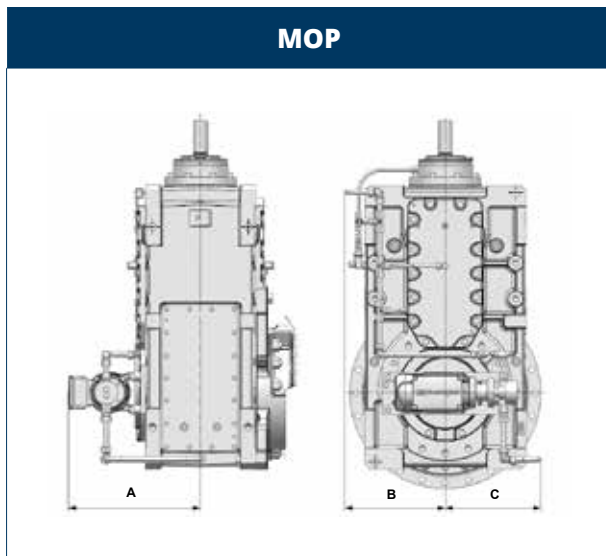

	A (min) [mm]	B (min) [mm]	C (min) [mm]
3/H 11L2	400	225	275
3/H 13L2			
3/H 15L3			
3/H 16L3			
3/H 17L3			
3/H 15L2	445	335	320
3/H 16L2			
3/H 18L3			
3/H 19L3			
3/H 17L2	460	365	330
3/H 21L3			
3/H 18L2	510	435	410
3/H 19L2			
3/H 23L3			
3/H 25L3			



The minimum overall dimensions A, B are approximate

MOP...

- Motor pump
- Y-filter 60 micron
- Minimum pressure

The motor pump arrangements shown above are approximate in the event that their position may vary due to the simultaneous presence of other optional devices.

For overall dimensions in the above case, please contact **Bonfiglioli's Technical Service**.

16.1.5 HEATERS – HE OPTION

Low ambient temperatures cause lubrication problems in the transmission due to the inability of the lubricant to reach all components.

The oil high viscosity can produce high starting torques resulting from the resistance of the components in contact with the lubricant bath. Furthermore, cooling units are not suitable for operating viscosities above 1500 cSt, viscosities normally reached at low temperatures.

In these cases, the HE option is offered, which consists of installing an electric heater and temperature sensor in the gear unit to raise the oil temperature to a condition useful for starting.

The gear unit is supplied with a 25°C thermostat with which to control the switching on and off of the heating element. Alternatively, if a different control is required, a PT100 probe can be connected to a PLC system with which to measure the temperature and control the switching on and off of the heating element as required.

Please refer to the “User Manual” available at www.bonfiglioli.com for more details.

All electrical connections are the responsibility of the customer and must be made before starting up the gear unit.



The HE option may be in conflict with other options, please contact **Bonfiglioli's Technical Service**.

HE

HE OPTION TABLE

	Q,tà	AB3	AB6		Q,tà	AB3	AB6		Q,tà	AB3	AB6		Q,tà	AB3	AB6
3/H 11L2	2	2 W/cm ² 220 V AC	2 W/cm ² 220 V AC	3/H 15L2	2	1.5 W/cm ² 220 V AC	2 W/cm ² 220 V AC	3/H 17L2	2	1.5 W/cm ² 220 V AC	2 W/cm ² 220 V AC	3/H 18L2	2	1.5 W/cm ² 220 V AC	2 W/cm ² 220 V AC
3/H 13L2				3/H 16L2				3/H 19L2							
3/H 15L3				3/H 18L3				3/H 21L3							
3/H 16L3				3/H 19L3				3/H 23L3							
3/H 17L3				3/H 25L3											

16.2 DRAIN VALVE

To facilitate oil draining during scheduled maintenance, 3/H gear units can be supplied with two drain valves (OD option)

KIT 1....

- Two-way valve
- T-fitting
- Straight fitting x 2
- Adapter
- Closed plugs x 2

KIT 2....

- Two-way valve
- 90° fitting
- Straight fitting
- Closed plug

The mounting positions of the drain valves are shown in the diagram

For positions other than the diagram below, please consult **Bonfiglioli's Technical Service**.

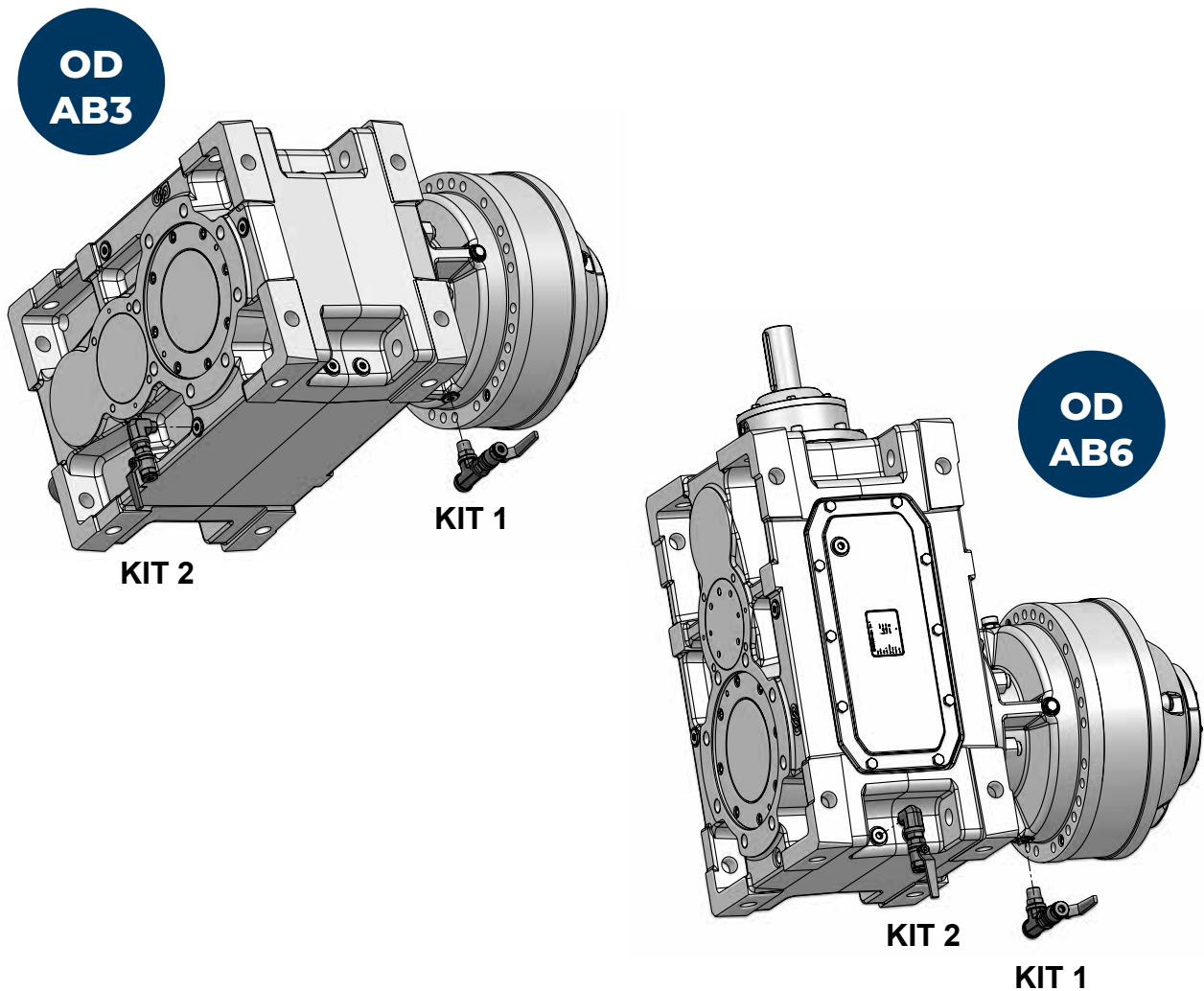

16.3 BACKSTOP DEVICE

The backstop ensures unidirectional operation of the gear unit and prevents rearward motion due to the load connected to the output shaft. Ensure that the torque demand required by the application is verified in compliance with this condition:

$$\frac{M_2}{\eta \times i} \leq M_{1 \max}$$

The specification of the relevant option, designated with letter A, must be completed by the indication of the direction of free rotation of the output shaft (**CW** or **CCW**).

If particular conditions of use so require, the direction of rotation of the backstop can be varied by the user by accessing the housing containing it, and reversing the direction of installation of the freewheel. If such an operation is required, contact **Bonfiglioli's Technical Service** for instructions. The particular type of backstop, consisting of contact bodies with centrifugal separation, does not require any kind of periodic maintenance.

The option is not available together with other configurations involving the same shaft end.

	i	L1	L2	R1	R2
3/H 11L2	30.3 - 65.0	DX	⊖	⊖	SX
3/H 11L2	76.0 - 270.3	SX	DX	SX	DX
3/H 11L2	355.4 - 1099	DX	SX	DX	SX
3/H 13L2	30.6 - 65.8	DX	⊖	⊖	SX
3/H 13L2	77.0 - 273.7	SX	DX	SX	DX
3/H 13L2	339.5 - 1113	DX	SX	DX	SX
3/H 15L2	93.5 - 1039	SX	DX	SX	DX
3/H 15L2	329.0 - 1039	DX	SX	DX	SX
3/H 15L3	128.8 - 354.6	SX	DX	SX	DX
3/H 15L3	414.8 - 1160	DX	SX	DX	SX
3/H 16L2	111.4 - 413.1	SX	DX	SX	DX
3/H 16L2	456.8 - 1150	DX	SX	DX	SX
3/H 16L3	128.8 - 354.6	SX	DX	SX	DX
3/H 16L3	414.8 - 1160	DX	SX	DX	SX
3/H 17L2	102.4 - 412.7	SX	DX	SX	DX
3/H 17L2	456.8 - 943.4	DX	SX	DX	SX
3/H 17L3	125.6 - 268.0	SX	DX	SX	DX
3/H 17L3	314.1 - 921.1	DX	SX	DX	SX
3/H 18L2	99.4 - 295.2	SX	DX	SX	DX
3/H 18L2	314.6 - 964.0	DX	SX	DX	SX
3/H 18L3	119.7 - 364.3	DX	⊖	⊖	SX
3/H 18L3	444.2 - 1128	SX	DX	SX	DX
3/H 19L2	105.6 - 387.2	SX	DX	SX	DX
3/H 19L2	412.6 - 1098	DX	SX	DX	SX
3/H 19L3	132.5 - 320.9	DX	⊖	⊖	SX
3/H 19L3	391.2 - 993.6	SX	DX	SX	DX
3/H 21L3	120.1 - 361.2	DX	⊖	⊖	SX
3/H 21L3	403.1 - 960.0	SX	DX	SX	DX
3/H 23L3	121.5 - 266.6	DX	⊖	⊖	SX
3/H 23L3	297.9 - 936.9	SX	DX	SX	DX
3/H 25L3	127.7 - 304.6	DX	⊖	⊖	SX
3/H 25L3	340.5 - 1071	SX	DX	SX	DX

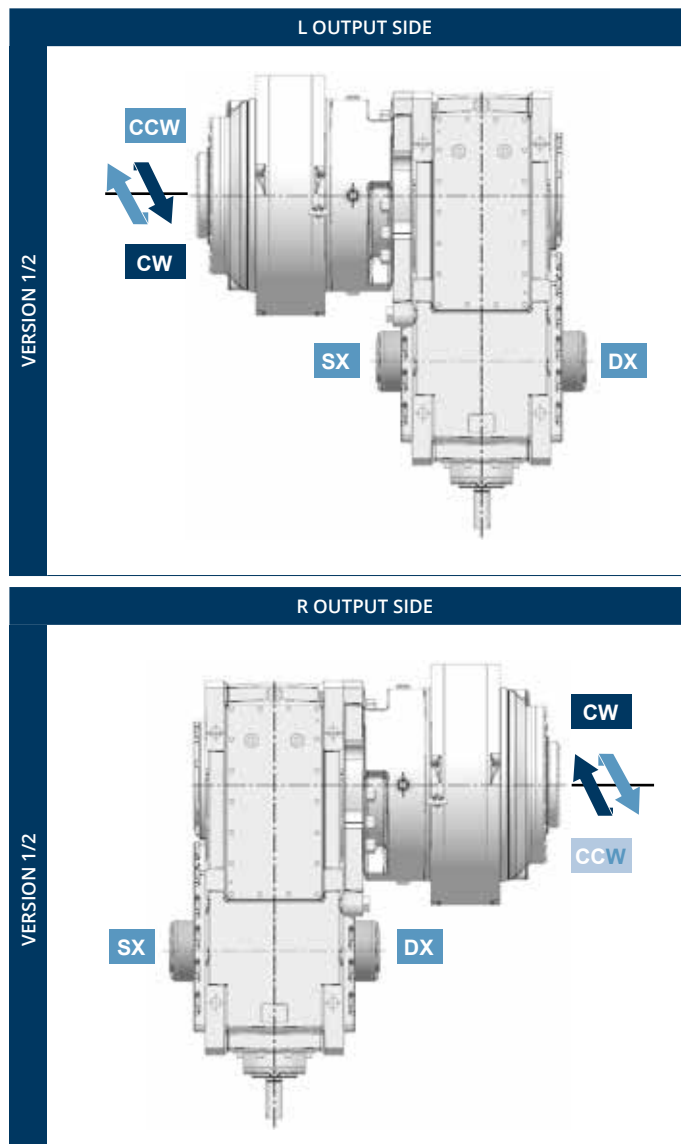

	i =	A [mm]	B [mm]	M _{1max} [Nm]	n _{1min} [Nm]
3/H 11L2	30.3 - 36.8			1310	935
3/H 11L2	42.1 - 51.1	175	279	175	1290
3/H 11L2	59.7 - 65.0			740	1640
3/H 11L2	76.0 - 125.2			610	930
3/H 11L2	150.9 - 270.3	130	259	340	1660
3/H 11L2	335.4 - 921.9			270	1455
3/H 11L2	1048 - 1099	110	250	130	(*)
3/H 13L2	30.6 - 37.3			1310	935
3/H 13L2	42.6 - 51.8	175	279	940	1290
3/H 13L2	60.4 - 65.8			175	1640
3/H 13L2	77.0 - 126.7			610	930
3/H 13L2	152.8 - 273.7	130	259	340	1660
3/H 13L2	339.5 - 933.2			270	1455
3/H 13L2	1061 - 1113	110	250	130	(*)
3/H 15L2	93.5 - 185.3			1190	1020
3/H 15L2	204.0 - 286.9	175	285	770	1585
3/H 15L2	329.0 - 517.2			400	1260
3/H 15L2	582.7 - 1039	125	278	250	(*)
3/H 15L3	128.8 - 156.6			1310	935
3/H 15L3	179.2 - 217.5	175	279	940	1290
3/H 15L3	254.0 - 354.6			740	1640
3/H 15L3	414.8 - 682.4			610	930
3/H 15L3	822.9 - 1160	130	259	340	1660

	i =	A [mm]	B [mm]	M _{1max} [Nm]	n _{1min} [Nm]
3/H 16L2	111.4			1550	785
3/H 16L2	117.3 - 232.4	175	285	1190	1020
3/H 16L2	255.8 - 413.1			770	1585
3/H 16L2	456.8 - 648.7			400	1260
3/H 16L2	730.7 - 1150	125	278	250	(*)
3/H 16L3	128.8 - 156.6			1310	935
3/H 16L3	179.2 - 217.5	175	279	940	1290
3/H 16L3	254.0 - 354.6			740	1640
3/H 16L3	414.8 - 682.4			610	930
3/H 16L3	822.9 - 1160	130	259	340	1660
3/H 17L2	102.4 - 129.2			1550	785
3/H 17L2	148.6 - 236.3	175	305	1190	1020
3/H 17L2	259.9 - 412.7			770	1585
3/H 17L2	456.8 - 851.6			400	1260
3/H 17L2	943.4	125	279	250	(*)
3/H 17L3	125.6 - 152.2			1310	935
3/H 17L3	173.8 - 210.6	175	279	940	1290
3/H 17L3	246.3 - 268.0			740	1640
3/H 17L3	314.1 - 516.6			610	930
3/H 17L3	623.9 - 921.1	130	259	340	1660

(*) Contact **Bonfiglioli's Technical Service**.

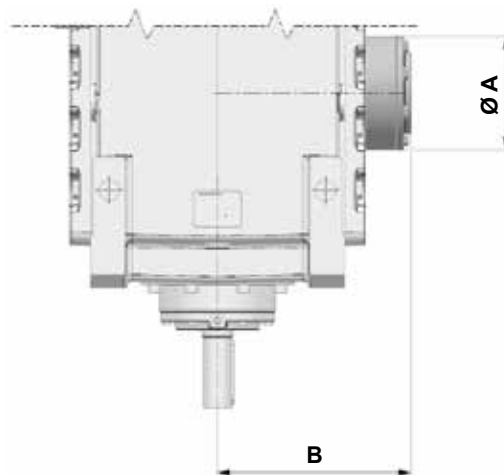

In permanent operation, it is advisable to maintain an idle (overdrive) rotation speed n_{1min} higher than that indicated in the table, in order to guarantee the centrifugal separation of all bodies, preserving them from wear.

For further information, please contact **Bonfiglioli's Technical Service**.

	i =	A [mm]	B [mm]	M _{1max} [Nm]	n _{1min} [Nm]
3/H 18L2	99.4 - 153.6			2290	880
3/H 18L2	168.5 - 295.2	210	402	1480	1365
3/H 18L2	314.6 - 837.3			1190	1020
3/H 18L2	964.0	175	366	770	1585
3/H 18L3	119.7 - 151.5			740	715
3/H 18L3	162.7 - 187.0			610	880
3/H 18L3	203.8 - 233.8	210	335	340	1100
3/H 18L3	252.5 - 364.3			270	1365
3/H 18L3	444.2 - 491.2			1550	785
3/H 18L3	517.0 - 1025	175	285	1190	1020
3/H 18L3	1128			770	1585
3/H 19L2	105.6 - 114.8			2840	715
3/H 19L2	130.4 - 201.4	210	402	2290	880
3/H 19L2	221.0 - 387.2			1480	1365
3/H 19L2	412.6 - 1098	175	366	1190	1020
3/H 19L3	132.5 - 167.7			740	715
3/H 19L3	180.1 - 207.0			610	880
3/H 19L3	225.6 - 258.8	210	335	340	1100
3/H 19L3	279.5 - 320.9			270	1365
3/H 19L3	391.2 - 432.6			1550	785
3/H 19L3	455.4 - 902.5	175	285	1190	1020
3/H 19L3	993.6			770	1585

	i =	A [mm]	B [mm]	M _{1max} [Nm]	n _{1min} [Nm]
3/H 21L3	120.1 - 188.7			3530	665
3/H 21L3	207.4 - 233.0			2850	820
3/H 21L3	258.6 - 291.3	230	336	2280	1025
3/H 21L3	319.2 - 361.2			1840	1275
3/H 21L3	403.1 - 573.2			1550	785
3/H 21L3	659.4 - 960.0	175	305	1190	1020
3/H 23L3	121.5 - 139.2			6630	575
3/H 23L3	150.9 - 172.5			5350	710
3/H 23L3	188.2 - 215.6	290	437	4280	890
3/H 23L3	235.2 - 266.6			3450	1105
3/H 23L3	297.9 - 390.0			2840	715
3/H 23L3	443.0 - 684.0	175	285	2290	880
3/H 23L3	750.7 - 936.9			1480	1365
3/H 25L3	127.7 - 159.0			6630	575
3/H 25L3	172.5 - 197.1			5350	710
3/H 25L3	215.0 - 246.4	290	437	4280	890
3/H 25L3	268.8 - 304.6			3450	1105
3/H 25L3	340.5 - 445.8			2840	715
3/H 25L3	506.2 - 781.8	175	285	2290	880
3/H 25L3	857.9 - 1071			1480	1365

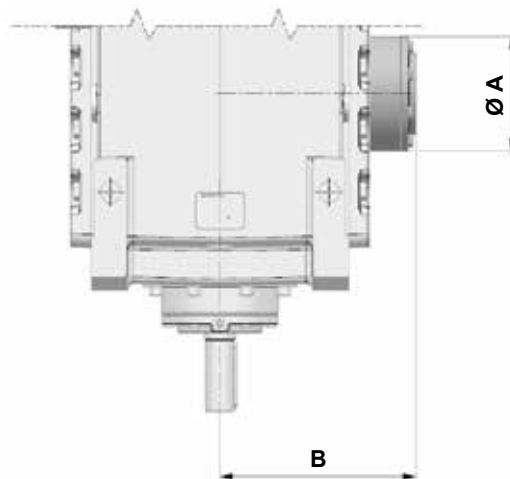

In permanent operation, it is advisable to maintain an idle (overdrive) rotation speed n_{1min} higher than that indicated in the table, in order to guarantee the centrifugal separation of all bodies, preserving them from wear.

For further information, please contact **Bonfiglioli's Technical Service**.

16.4 PRIMARY BRAND BEARINGS

This **PBB** option provides for the assembly of primary brand bearings for the helical bevel gear unit. Performance remains unchanged.

16.5 SEALS AND GASKETS

On request, the gear units can be fitted with different sealing systems, in particular:

TK – In environments characterised by the presence of abrasive dust, Taconite type seals consisting of a combination of oil seals, labyrinth seals and grease chamber are recommended.

The presence of grease must be guaranteed through periodic maintenance. For sizes 3/H 11L2 and 3/H 13L2 the option is not available; for sizes 3/H 15L3, 3/H 16L3 and 3/H 17L3 the Taconite seals are only provided on the output shaft.

VS – Equipped with fluoro elastomer oil seals.

16.6 VENT FILTER WITH DRYING SALTS

The **DBF** option includes a vent with a filter to protect the gear unit from external environment contamination such as moisture that can cause rusting of internal components and degradation of the oil's lubricating capacity, and fine particulate matter that induces premature wear of gears, bearings and seals.

The change of colour of the gel contained inside the filter indicates that the solution adopted is working correctly and efficiently. The control valve in the device ensures that no overpressure is created inside the gear unit (opening at 0.017 bar).

For installing the device, please refer to the "User Manual" available at www.bonfiglioli.com.

16.7 SENSORS

Bimetallic thermostat - A bimetallic thermostatic probe is supplied as part of the TG option to detect when the oil temperature exceeds $90^{\circ}\text{C} \pm 5^{\circ}\text{C}$. The device is supplied and installation and the relevant electrical wiring are the responsibility of the installer.

PT100 Probe - When the PT100 option is specified, an analogue temperature probe is supplied to detect the oil temperature.

For temperature values for gear unit operation, please refer to the "User Manual" available at www.bonfiglioli.com.

16.8 FIXING ELEMENTS

For the shaft mounting of 3/H gear units, a suitably shaped steel arm can be supplied to fix the gear unit to the support structure. The kit also includes screws and nuts for fixing to the gear unit and the joint for fixing to the machine. It will be the customer's responsibility to install the complete kit on their own system by consulting the "User Manual" available at www.bonfiglioli.com.

For positions other than the diagram below, please consult **Bonfiglioli's Technical Service**.

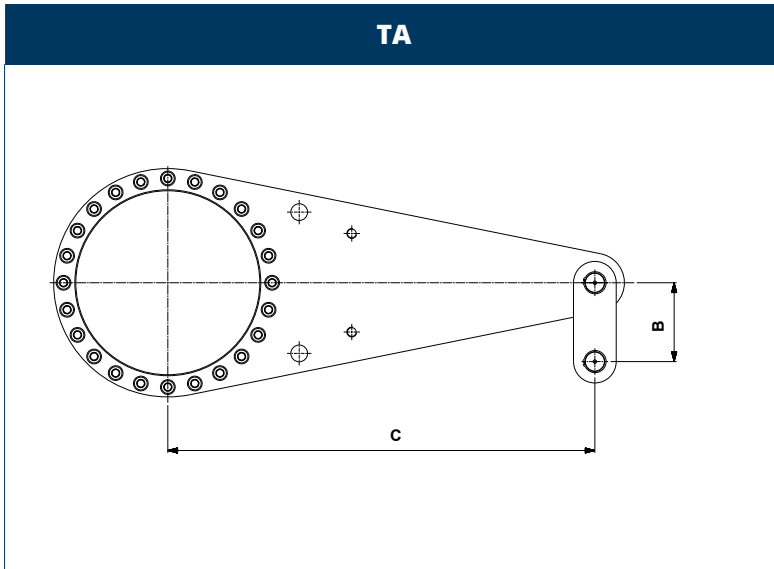

	C [mm]	B [mm]
3/H 11L2	800	155
3/H 13L2	900	160
3/H 15L2	1100	200
3/H 15L3		
3/H 16L2	1280	210
3/H 16L3		
3/H 17L2	1300	240
3/H 17L3		
3/H 18L2	1900	280
3/H 18L3		
3/H 19L2	1500	320
3/H 19L3		
3/H 21L3	1500	360
3/H 23L3	1750	400
3/H 25L3	2050	440

TORQUE ARM POSITION

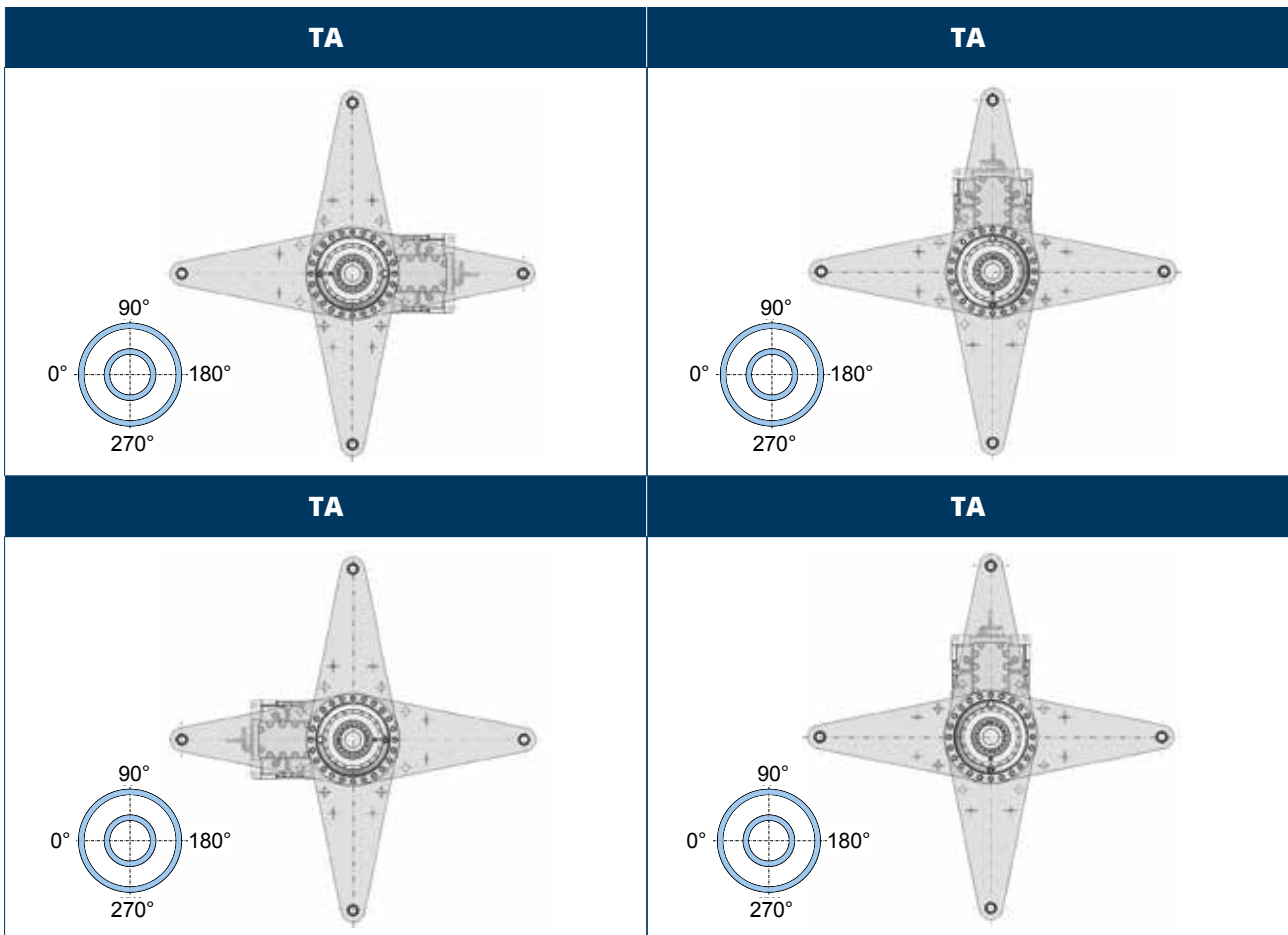

16.9 SURFACE PROTECTION

The gear units, which, where no specific protection class is required, in the painted (ferrous) areas comply with protection class C3 (UNI EN ISO 12944-2) as a minimum requirement, are supplied with surface protection C4 for improved resistance to atmospheric corrosion, obtained by paint coating the complete assembly.

SURFACE PROTECTION	Typical environments	Max. surface temperature	Corrosion class according to UNI EN ISO 12944-2
C3	Urban and industrial environments, with max.100% relative air humidity (medium ambient pollution)	120 °C	C3
C4	Industrial areas, coastal areas, chemical plants, with max.100% relative air humidity (high environmental pollution)	120 °C	C4

16.10 PAINT COATING

The gear units, which, where no specific protection class is required, in the painted (ferrous) areas comply with protection class C3 (UNI EN ISO 12944-2) as a minimum requirement, are supplied with surface protection C4 for improved resistance to atmospheric corrosion, obtained by paint coating the complete assembly.

PAINT COATING	COLOUR	RAL number
RAL7042*	Traffic Grey A	7042
RAL5010	Gentian Blue	5010
RAL9005	Jet Black	9005
RAL9006	White Aluminium	9006
RAL9010	Pure White	9010
RAL7035	Light grey	7035
RAL7001	Silver Grey	7001
RAL5015	Sky Blue	5015
RAL7037	Dusty Grey	7037
RAL5024	Pastel blue	5024

* Standard supply colour unless otherwise specified

NOTE - The "PAINT COATING" option can only be specified in combination with the "SURFACE PROTECTION" option.

16.11 LONG-TERM STORAGE

With the long-term storage option, the configured product is supplied without the standard lubricating oil but with an anti-corrosion protective liquid to guarantee the integrity and full functionality of the gear unit in cases where the unit will not be immediately installed but will be stored for a long period of time (installation beyond 6 months from the delivery date).

After two years of storage, the unit with long-term storage option must be checked by the Bonfiglioli service centre. In case the product is not properly stored, an offer for complete restoration of the unit will be issued by Bonfiglioli.

The SL option can be requested in 2 versions:

- **SLM Long-term storage_Mineral Oil:** option with anti-corrosion protective oil compatible with all lubricating mineral oils and synthetically based Poly-alphaolefin (PAO) oils listed in the Bonfiglioli "Installation, Use and Maintenance" manual.
- **SLP Long-term storage_Polyglycol Oil:** option with anti-corrosion protective oil compatible with all the synthetic-based PolyGlycol (PAG) lubricating oils listed in the Bonfiglioli "Installation, Use and Maintenance" manual.

Note: Only one version can be selected. The SLM and SLP options cannot be selected at the same time.

When configuring a gear unit or gearmotor with the Long Term Storage option, it is necessary to know the type of lubricating oil that will be used during the operating period (mineral oil or polyglycol). Before commissioning a Bonfiglioli product with this option, make sure that the lubricating oil is filled via the filling plug (filler plug) determined by the mounting position indicated on the nameplate.

Lubricant quantity

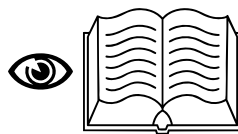

16.12 CERTIFICATES

AC - Certificate of compliance

The document certifies the compliance of the product with the purchase order and the construction in conformity with the applicable procedures of Bonfiglioli Riduttori Quality gear unit system.

CC - Inspection certificate

This specification involves checking on order compliance, visual inspections of the general external conditions, and inspections with tools of the coupling dimensions.

General operational checks in unloaded conditions are also carried out, including testing the oil seal integrity both in static conditions and during operation. The inspection is performed on a statistical sample from the shipping batch.

CT - Type certificate

In addition to the procedures included in the Inspection certificate, the following specific functional checks are also carried out:

- noise level inspection
- surface temperature under running conditions
- tightening torque check on external fasteners
- functionality of any auxiliary components

All procedures are carried out with the gear unit operating in unloaded conditions. The inspection is performed on a statistical sample from the shipping batch.

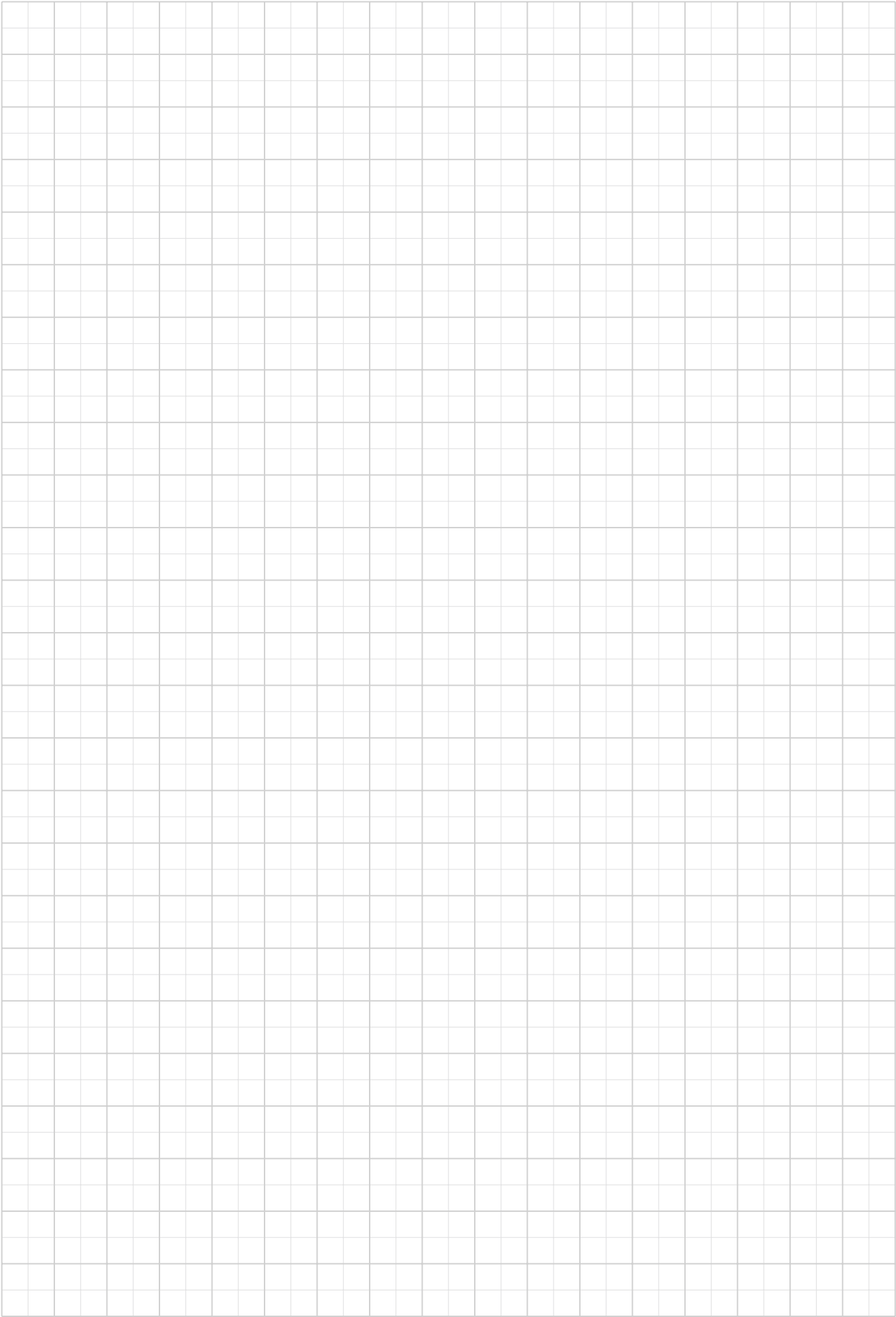

Technical data



17. PERFORMANCE AND THERMAL POWER

3/H 11L2					n1 = 1800 min ⁻¹				M ₂ Max [Nm]
	i	n2 [min ₁]	Mn ₂ [Nm]	Pn ₁ [kW]	T _{amb} = 20°C	T _{amb} = 40°C	T _{amb} = 20°C	T _{amb} = 40°C	
					P _{TB} [kW]		P _{TFAN} [kW]		
3/H 11L2	30.3	59.5	29500	202	80	36	167	100	55000
3/H 11L2	33.9	53.0	30540	186	82	37	167	99	
3/H 11L2	36.8	48.9	31290	176	74	34	156	94	
3/H 11L2	42.1	42.7	32580	160	82	41	160	99	
3/H 11L2	47.0	38.3	33680	148	82	41	157	96	
3/H 11L2	51.1	35.2	34530	140	74	38	147	91	
3/H 11L2	59.7	30.1	36180	126	75	39	143	89	
3/H 11L2	65.0	27.7	37110	118	68	36	133	84	
3/H 11L2	76.0	23.7	38890	106	59	34	144	74	
3/H 11L2	84.6	21.3	40170	98	59	34	113	74	
3/H 11L2	92.1	19.5	41200	93	54	31	107	70	
3/H 11L2	98.6	18.3	41190	87	56	33	108	71	
3/H 11L2	119.0	15.1	41120	72	52	31	102	68	
3/H 11L2	125.2	14.4	41100	68	53	32	102	68	
3/H 11L2	150.9	11.9	41030	56	49	30	96	64	
3/H 11L2	164.4	10.9	41010	52	46	28	92	62	
3/H 11L2	175.5	10.3	41040	48	47	29	92	62	
3/H 11L2	212.7	8.5	41410	40	46	29	88	60	
3/H 11L2	222.9	8.1	41730	39	46	29	87	59	
3/H 11L2	248.3	7.3	42470	37	46	29	85	58	
3/H 11L2	270.3	6.7	43090	33	43	27	81	55	
3/H 11L2	335.4	5.4	44680	28	46	31	76	53	
3/H 11L2	373.4	4.8	45500	25	46	31	75	53	
3/H 11L2	389.8	4.6	46630	24	47	32	76	53	
3/H 11L2	483.0	3.7	46650	20	44	30	73	51	
3/H 11L2	525.6	3.4	46640	18	41	28	69	49	
3/H 11L2	560.7	3.2	46650	17	39	27	67	48	
3/H 11L2	651.5	2.8	46660	15	38	26	66	46	
3/H 11L2	725.6	2.5	46660	13	38	26	65	46	
3/H 11L2	828.2	2.2	46660	12	36	25	63	45	
3/H 11L2	921.9	2.0	46660	10	36	25	62	44	
3/H 11L2	1048	1.7	46660	9	33	23	59	42	
3/H 11L2	1099	1.6	46660	9	33	23	58	42	

3/H 11L2

$n_1 = 1500 \text{ min}^{-1}$



	i	n ₂ [min ₁]	Mn ₂ [Nm]	Pn ₁ [kW]	T _{amb} = 20°C	T _{amb} = 40°C	T _{amb} = 20°C	T _{amb} = 40°C	M ₂ Max [Nm]
					P _{TB} [kW]		P _{TFAN} [kW]		
3/H 11L2	30.3	49.6	31160	178	102	56	179	112	55000
3/H 11L2	33.9	44.2	32260	164	103	56	177	111	
3/H 11L2	36.8	40.7	33050	155	91	51	163	104	
3/H 11L2	42.1	35.6	34410	141	99	57	168	108	
3/H 11L2	47.0	31.9	35570	131	98	57	164	105	
3/H 11L2	51.1	29.3	36470	123	87	51	151	98	
3/H 11L2	59.7	25.1	38210	110	88	52	147	96	
3/H 11L2	65.0	23.1	39200	104	79	47	136	89	
3/H 11L2	76.0	19.7	41080	93	67	42	115	77	
3/H 11L2	84.6	17.7	41250	84	67	41	114	76	
3/H 11L2	92.1	16.3	41220	77	61	38	107	72	
3/H 11L2	98.6	15.2	41190	72	63	40	109	74	
3/H 11L2	119.0	12.6	41120	60	57	36	101	68	
3/H 11L2	125.2	12.0	41100	57	58	38	101	70	
3/H 11L2	150.9	9.9	41030	47	55	35	96	65	
3/H 11L2	164.4	9.1	41010	43	51	33	91	62	
3/H 11L2	175.5	8.5	41040	40	52	33	91	62	
3/H 11L2	212.7	7.1	41410	34	49	33	86	60	
3/H 11L2	222.9	6.7	41730	32	50	33	86	59	
3/H 11L2	248.3	6.0	42470	30	50	33	84	58	
3/H 11L2	270.3	5.5	43090	28	46	31	79	55	
3/H 11L2	335.4	4.5	44680	23	47	33	73	52	
3/H 11L2	373.4	4.0	45500	21	47	33	73	52	
3/H 11L2	389.8	3.8	45830	20	48	33	74	52	
3/H 11L2	483.0	3.1	46650	17	45	31	70	49	
3/H 11L2	525.6	2.9	46640	15	42	30	67	48	
3/H 11L2	560.7	2.7	46650	14	40	28	65	46	
3/H 11L2	651.5	2.3	46660	12	39	28	63	46	
3/H 11L2	725.6	2.1	46660	11	39	27	63	45	
3/H 11L2	828.2	1.8	46660	10	37	26	60	43	
3/H 11L2	921.9	1.6	46660	9	37	26	60	43	
3/H 11L2	1048	1.4	46660	8	34	24	56	41	
3/H 11L2	1099	1.3	46660	7	34	24	56	40	



3/H 13L2

$n_1 = 1800 \text{ min}^{-1}$



	i	n ₂ [min ₁]	Mn ₂ [Nm]	Pn ₁ [kW]	T _{amb} = 20°C		T _{amb} = 40°C		M ₂ Max [Nm]
					P _{TB} [kW]	P _{TFAN} [kW]	P _{TB} [kW]	P _{TFAN} [kW]	
3/H 13L2	30.6	58.8	33370	226	80	36	167	100	79000
3/H 13L2	34.4	52.4	37150	224	82	37	167	99	
3/H 13L2	37.3	48.3	39250	218	74	34	156	94	
3/H 13L2	42.6	42.2	34360	167	82	41	160	99	
3/H 13L2	47.6	37.8	38260	166	82	41	157	96	
3/H 13L2	51.8	34.8	41640	167	74	38	147	91	
3/H 13L2	60.4	29.8	39790	136	75	39	143	89	
3/H 13L2	65.8	27.3	43300	136	68	36	133	84	
3/H 13L2	77.0	23.4	44160	119	59	34	114	74	
3/H 13L2	85.7	21.0	49170	119	59	34	113	74	
3/H 13L2	93.2	19.3	50650	113	54	31	107	70	
3/H 13L2	99.8	18.0	48820	101	56	33	108	71	
3/H 13L2	120.5	14.9	50520	87	52	31	102	68	
3/H 13L2	126.7	14.2	50490	83	53	32	102	68	
3/H 13L2	152.8	11.8	50410	68	49	30	96	64	
3/H 13L2	166.4	10.8	50370	63	46	28	92	62	
3/H 13L2	177.6	10.1	50420	59	47	29	92	62	
3/H 13L2	215.3	8.4	50810	49	46	29	88	60	
3/H 13L2	225.6	8.0	51210	47	46	29	87	59	
3/H 13L2	251.3	7.2	52140	43	46	29	85	58	
3/H 13L2	273.7	6.6	52880	40	43	27	81	55	
3/H 13L2	339.5	5.3	46710	29	46	31	76	53	
3/H 13L2	378.0	4.8	52010	29	46	31	75	53	
3/H 13L2	394.5	4.6	56220	30	47	32	76	53	
3/H 13L2	488.9	3.7	57730	24	44	30	73	51	
3/H 13L2	532.0	3.4	57740	22	41	28	69	49	
3/H 13L2	567.6	3.2	57740	21	39	27	67	48	
3/H 13L2	659.5	2.7	57750	18	38	26	66	46	
3/H 13L2	734.4	2.5	57750	16	38	26	65	46	
3/H 13L2	838.4	2.1	57750	14	36	25	63	45	
3/H 13L2	933.2	1.9	57750	13	36	25	62	44	
3/H 13L2	1061	1.7	57760	11	33	23	59	42	
3/H 13L2	1113	1.6	58020	11	33	23	58	42	

3/H 13L2

$n_1 = 1500 \text{ min}^{-1}$



	i	n ₂ [min ⁻¹]	Mn ₂ [Nm]	Pn ₁ [kW]	T _{amb} = 20°C		T _{amb} = 40°C		M ₂ Max [Nm]
					P _{TB} [kW]	P _{TFAN} [kW]	P _{TB} [kW]	P _{TFAN} [kW]	
3/H 13L2	30.6	49.0	35240	199	102	56	179	112	79000
3/H 13L2	34.4	43.7	39240	197	103	56	177	111	
3/H 13L2	37.3	40.3	41460	192	91	51	163	104	
3/H 13L2	42.6	35.2	36300	147	99	57	168	108	
3/H 13L2	47.6	31.5	40410	147	98	57	164	105	
3/H 13L2	51.8	29.0	43980	147	87	51	151	98	
3/H 13L2	60.4	24.8	42030	120	88	52	147	96	
3/H 13L2	65.8	22.8	45740	120	79	47	136	89	
3/H 13L2	77.0	19.5	46650	105	67	42	115	77	
3/H 13L2	85.7	17.5	50700	102	67	41	114	76	
3/H 13L2	93.2	16.1	50650	94	61	38	107	72	
3/H 13L2	99.8	15.0	50620	88	63	40	109	74	
3/H 13L2	120.5	12.5	50520	72	57	36	101	68	
3/H 13L2	126.7	11.8	50490	69	58	38	101	70	
3/H 13L2	152.8	9.8	50410	57	55	35	96	65	
3/H 13L2	166.4	9.0	50370	52	51	33	91	62	
3/H 13L2	177.6	8.4	50420	49	52	33	91	62	
3/H 13L2	215.3	7.0	50810	41	49	33	86	60	
3/H 13L2	225.6	6.6	51210	39	50	33	86	59	
3/H 13L2	251.3	6.0	52140	36	50	33	84	58	
3/H 13L2	273.7	5.5	52880	33	46	31	79	55	
3/H 13L2	339.5	4.4	49340	25	47	33	73	52	
3/H 13L2	378.0	4.0	54940	25	47	33	73	52	
3/H 13L2	394.5	3.8	56220	25	48	33	74	52	
3/H 13L2	488.9	3.1	57730	20	45	31	70	49	
3/H 13L2	532.0	2.8	57740	19	42	30	67	48	
3/H 13L2	567.6	2.6	57740	18	40	28	65	46	
3/H 13L2	659.5	2.3	57750	15	39	28	63	46	
3/H 13L2	734.4	2.0	57750	14	39	27	63	45	
3/H 13L2	838.4	1.8	57750	12	37	26	60	43	
3/H 13L2	933.2	1.6	57750	11	37	26	60	43	
3/H 13L2	1061	1.4	57760	9	34	24	56	41	
3/H 13L2	1113	1.3	58020	9	34	24	56	40	



3/H 15L2

$n_1 = 1800 \text{ min}^{-1}$



	i	n ₂ [min.]	Mn ₂ [Nm]	Pn ₁ [kW]	T _{amb} = 20°C		T _{amb} = 40°C		M ₂ Max [Nm]
					P _{TB} [kW]		P _{TFAN} [kW]		
3/H 15L2	93.5	19.3	74610	165	117	74	199	134	135000
3/H 15L2	104.6	17.2	75670	150	115	73	195	132	
3/H 15L2	115.6	15.6	80050	143	111	71	189	129	
3/H 15L2	131.3	13.7	79920	126	107	69	183	125	
3/H 15L2	145.8	12.3	85160	121	106	69	180	123	
3/H 15L2	167.0	10.8	83600	104	102	66	173	118	
3/H 15L2	185.3	9.7	88630	99	99	65	168	116	
3/H 15L2	204.0	8.8	88360	90	96	63	163	112	
3/H 15L2	225.7	8.0	89000	82	93	62	157	109	
3/H 15L2	259.3	6.9	90220	72	91	61	152	106	
3/H 15L2	286.9	6.3	93430	67	89	60	147	103	
3/H 15L2	329.0	5.5	89190	56	86	60	132	94	
3/H 15L2	364.2	4.9	94170	54	84	59	130	92	
3/H 15L2	411.0	4.4	87400	44	80	56	125	89	
3/H 15L2	462.8	3.9	94530	42	80	57	125	90	
3/H 15L2	517.2	3.5	91630	37	75	53	119	85	
3/H 15L2	582.7	3.1	86620	31	74	53	118	85	
3/H 15L2	657.5	2.7	93290	29	71	51	114	83	
3/H 15L2	740.8	2.4	94540	26	71	51	113	82	
3/H 15L2	827.5	2.2	94770	24	69	49	111	80	
3/H 15L2	916.7	2.0	94670	21	70	51	111	81	
3/H 15L2	1039	1.7	95110	19	69	50	109	79	

3/H 15L2

$n_1 = 1500 \text{ min}^{-1}$



	i	n ₂ [min. ₁]	Mn ₂ [Nm]	Pn ₁ [kW]	T _{amb} = 20°C		T _{amb} = 40°C		M ₂ Max [Nm]
					P _{TB} [kW]		P _{TFAN} [kW]		
3/H 15L2	93.5	16.0	78810	145	124	82	196	135	135000
3/H 15L2	104.6	14.3	79930	132	120	80	190	132	
3/H 15L2	115.6	13.0	84550	126	116	78	185	129	
3/H 15L2	131.3	11.4	84410	111	113	75	180	124	
3/H 15L2	145.8	10.3	88330	105	111	75	176	123	
3/H 15L2	167.0	9.0	87920	91	107	72	169	118	
3/H 15L2	185.3	8.1	88630	83	104	70	164	114	
3/H 15L2	204.0	7.4	88360	75	99	68	157	111	
3/H 15L2	225.7	6.6	89000	68	96	66	152	107	
3/H 15L2	259.3	5.8	92780	62	94	65	147	104	
3/H 15L2	286.9	5.2	93430	56	92	63	143	100	
3/H 15L2	329.0	4.6	94200	49	86	61	126	91	
3/H 15L2	364.2	4.1	94170	45	84	60	124	89	
3/H 15L2	411.0	3.6	92320	39	80	57	120	86	
3/H 15L2	462.8	3.2	94530	35	80	58	119	87	
3/H 15L2	517.2	2.9	95110	32	76	54	115	82	
3/H 15L2	582.7	2.6	91490	27	74	54	112	82	
3/H 15L2	657.5	2.3	94910	25	71	51	109	79	
3/H 15L2	740.8	2.0	94540	22	71	51	108	78	
3/H 15L2	827.5	1.8	94770	20	69	50	105	77	
3/H 15L2	916.7	1.6	94670	18	70	51	106	77	
3/H 15L2	1039	1.4	95110	16	69	50	104	76	



3/H 15L3

$n_1 = 1800 \text{ min}^{-1}$



	i	n ₂ [min ₁]	Mn ₂ [Nm]	Pn ₁ [kW]	T _{amb} = 20°C	T _{amb} = 40°C	T _{amb} = 20°C	T _{amb} = 40°C	M ₂ Max [Nm]
					P _{TB} [kW]		P _{TFAN} [kW]		
3/H 15L3	128.8	14.0	89040	143	80	36	167	100	135000
3/H 15L3	144.4	12.5	88150	126	82	37	167	99	
3/H 15L3	156.6	11.5	88300	117	74	34	156	94	
3/H 15L3	179.2	10.0	89070	103	82	41	160	99	
3/H 15L3	200.1	9.0	87970	91	82	41	157	96	
3/H 15L3	217.5	8.3	90200	86	74	38	147	91	
3/H 15L3	254.0	7.1	92340	75	75	39	143	89	
3/H 15L3	276.7	6.5	92550	69	68	36	133	84	
3/H 15L3	278.8	6.5	92500	69	74	38	147	91	
3/H 15L3	325.6	5.5	94530	60	75	39	143	89	
3/H 15L3	354.6	5.1	94560	55	68	36	133	84	
3/H 15L3	414.8	4.3	94960	47	59	34	114	74	
3/H 15L3	461.6	3.9	94330	42	59	34	113	74	
3/H 15L3	501.8	3.6	94170	39	54	31	107	70	
3/H 15L3	537.4	3.3	94770	37	56	33	108	71	
3/H 15L3	648.9	2.8	94470	30	52	31	102	68	
3/H 15L3	682.4	2.6	94430	29	53	32	102	68	
3/H 15L3	822.9	2.2	94480	24	49	30	96	64	
3/H 15L3	896.5	2.0	94470	22	46	28	92	62	
3/H 15L3	956.7	1.9	94210	20	47	29	92	62	
3/H 15L3	1160	1.6	96540	17	46	29	88	60	

3/H 15L3

$n_1 = 1500 \text{ min}^{-1}$



	i	n ₂ [min ₁]	Mn ₂ [Nm]	Pn ₁ [kW]	T _{amb} = 20°C		T _{amb} = 40°C		M ₂ Max [Nm]
					P _{TB} [kW]		P _{TFAN} [kW]		
3/H 15L3	128.8	11.6	89040	119	102	56	179	112	135000
3/H 15L3	144.4	10.4	88150	105	103	56	177	111	
3/H 15L3	156.6	9.6	88300	97	91	51	163	104	
3/H 15L3	179.2	8.4	89070	86	99	57	168	108	
3/H 15L3	200.1	7.5	87970	76	98	57	164	105	
3/H 15L3	217.5	6.9	90200	72	87	51	151	98	
3/H 15L3	254.0	5.9	92340	63	88	52	147	96	
3/H 15L3	276.7	5.4	92550	58	79	47	136	89	
3/H 15L3	278.8	5.4	92500	57	87	51	151	98	
3/H 15L3	325.6	4.6	94530	50	88	52	147	96	
3/H 15L3	354.6	4.2	94560	46	79	47	136	89	
3/H 15L3	414.8	3.6	94960	40	67	42	115	77	
3/H 15L3	461.6	3.2	94330	35	67	41	114	76	
3/H 15L3	501.8	3.0	94170	32	61	38	107	72	
3/H 15L3	537.4	2.8	94770	30	63	40	109	74	
3/H 15L3	648.9	2.3	94470	25	57	36	101	68	
3/H 15L3	682.4	2.2	94430	24	58	38	101	70	
3/H 15L3	822.9	1.8	94480	20	55	35	96	65	
3/H 15L3	896.5	1.7	94470	18	51	33	91	62	
3/H 15L3	956.7	1.6	94210	17	52	33	91	62	
3/H 15L3	1160	1.3	96540	14	49	33	86	60	



3/H 16L2

$n_1 = 1800 \text{ min}^{-1}$



	i	n ₂ [min ₁]	Mn ₂ [Nm]	Pn ₁ [kW]	T _{amb} = 20°C		T _{amb} = 40°C		M ₂ Max [Nm]
					P _{TB} [kW]	P _{TFAN} [kW]	P _{TB} [kW]	P _{TFAN} [kW]	
3/H 16L2	111.4	16.2	92800	173	97	57	180	118	178000
3/H 16L2	117.3	15.4	93570	165	117	74	199	134	
3/H 16L2	131.1	13.7	94900	150	115	73	195	132	
3/H 16L2	145.0	12.4	98650	141	111	71	189	129	
3/H 16L2	164.7	10.9	99670	125	107	69	183	125	
3/H 16L2	182.8	9.8	98250	111	106	69	180	123	
3/H 16L2	209.5	8.6	99450	98	102	66	173	118	
3/H 16L2	232.4	7.7	99360	89	99	65	168	116	
3/H 16L2	255.8	7.0	98070	79	96	63	163	112	
3/H 16L2	283.0	6.4	98450	72	93	62	157	109	
3/H 16L2	325.1	5.5	99090	63	91	61	152	106	
3/H 16L2	359.8	5.0	99020	57	89	60	147	103	
3/H 16L2	413.1	4.4	100600	50	87	59	142	99	
3/H 16L2	456.8	3.9	102300	46	84	59	130	92	
3/H 16L2	515.4	3.5	104370	42	80	56	125	89	
3/H 16L2	580.4	3.1	106470	38	80	57	125	90	
3/H 16L2	648.7	2.8	108460	35	75	53	119	85	
3/H 16L2	730.7	2.5	108640	31	74	53	118	85	
3/H 16L2	824.6	2.2	112570	28	71	51	114	83	
3/H 16L2	929.0	1.9	112800	25	71	51	113	82	
3/H 16L2	1038	1.7	114210	23	69	49	111	80	
3/H 16L2	1150	1.6	116320	21	70	51	111	81	

3/H 16L2

$n_1 = 1500 \text{ min}^{-1}$



	i	n ₂ [min ₁]	Mn ₂ [Nm]	Pn ₁ [kW]	T _{amb} = 20°C	T _{amb} = 40°C	T _{amb} = 20°C	T _{amb} = 40°C	M ₂ Max [Nm]
					P _{TB} [kW]		P _{TFAN} [kW]		
3/H 16L2	111.4	13.5	98010	152	107	68	180	122	178000
3/H 16L2	117.3	12.8	98840	145	124	82	196	135	
3/H 16L2	131.1	11.4	100240	132	120	80	190	132	
3/H 16L2	145.0	10.3	98650	117	116	78	185	129	
3/H 16L2	164.7	9.1	99670	104	113	75	180	124	
3/H 16L2	182.8	8.2	98250	93	111	75	176	123	
3/H 16L2	209.5	7.2	99450	82	107	72	169	118	
3/H 16L2	232.4	6.5	99360	74	104	70	164	114	
3/H 16L2	255.8	5.9	98070	66	99	68	157	111	
3/H 16L2	283.0	5.3	98450	60	96	66	152	107	
3/H 16L2	325.1	4.6	99090	53	94	65	147	104	
3/H 16L2	359.8	4.2	99020	48	92	63	143	100	
3/H 16L2	413.1	3.6	100600	42	89	62	137	97	
3/H 16L2	456.8	3.3	102300	39	84	60	124	89	
3/H 16L2	515.4	2.9	104370	35	80	57	120	86	
3/H 16L2	580.4	2.6	106470	32	80	58	119	87	
3/H 16L2	648.7	2.3	108460	29	76	54	115	82	
3/H 16L2	730.7	2.1	110620	26	74	54	112	82	
3/H 16L2	824.6	1.8	112570	24	71	51	109	79	
3/H 16L2	929.0	1.6	112800	21	71	51	108	78	
3/H 16L2	1038	1.4	114210	19	69	50	105	77	
3/H 16L2	1150	1.3	116320	17	70	51	106	77	



3/H 16L3

$n_1 = 1800 \text{ min}^{-1}$



	i	n ₂ [min ₁]	Mn ₂ [Nm]	Pn ₁ [kW]	T _{amb} = 20°C		T _{amb} = 40°C		M ₂ Max [Nm]
					P _{TB} [kW]	P _{TFAN} [kW]	P _{TB} [kW]	P _{TFAN} [kW]	
3/H 16L3	128.8	14.0	118380	190	80	36	167	100	178000
3/H 16L3	144.4	12.5	117470	168	82	37	167	99	
3/H 16L3	156.6	11.5	117810	156	74	34	156	94	
3/H 16L3	179.2	10.0	117460	136	82	41	160	99	
3/H 16L3	200.1	9.0	118470	123	82	41	157	96	
3/H 16L3	217.5	8.3	118360	113	74	38	147	91	
3/H 16L3	254.0	7.1	118200	96	75	39	143	89	
3/H 16L3	276.7	6.5	118130	88	68	36	133	84	
3/H 16L3	278.8	6.5	118130	88	74	38	147	91	
3/H 16L3	325.6	5.5	121000	77	75	39	143	89	
3/H 16L3	354.6	5.1	122700	72	68	36	133	84	
3/H 16L3	414.8	4.3	125910	63	59	34	114	74	
3/H 16L3	461.6	3.9	126360	57	59	34	113	74	
3/H 16L3	501.8	3.6	126530	52	54	31	107	70	
3/H 16L3	537.4	3.3	126380	49	56	33	108	71	
3/H 16L3	648.9	2.8	126400	40	52	31	102	68	
3/H 16L3	682.4	2.6	125660	38	53	32	102	68	
3/H 16L3	822.9	2.2	126420	32	49	30	96	64	
3/H 16L3	896.5	2.0	126420	29	46	28	92	62	
3/H 16L3	956.7	1.9	126430	27	47	29	92	62	
3/H 16L3	1160	1.6	128650	23	46	29	88	60	

3/H 16L3

$n_1 = 1500 \text{ min}^{-1}$



	i	n ₂ [min ₁]	Mn ₂ [Nm]	Pn ₁ [kW]	T _{amb} = 20°C		T _{amb} = 40°C		M ₂ Max [Nm]
					P _{TB} [kW]		P _{TFAN} [kW]		
3/H 16L3	128.8	11.6	118380	159	102	56	179	112	178000
3/H 16L3	144.4	10.4	117470	140	103	56	177	111	
3/H 16L3	156.6	9.6	117810	130	91	51	163	104	
3/H 16L3	179.2	8.4	117460	113	99	57	168	108	
3/H 16L3	200.1	7.5	118470	102	98	57	164	105	
3/H 16L3	217.5	6.9	118360	94	87	51	151	98	
3/H 16L3	254.0	5.9	118200	80	88	52	147	96	
3/H 16L3	276.7	5.4	118130	74	79	47	136	89	
3/H 16L3	278.8	5.4	118130	73	87	51	151	98	
3/H 16L3	325.6	4.6	121000	64	88	52	147	96	
3/H 16L3	354.6	4.2	122700	60	79	47	136	89	
3/H 16L3	414.8	3.6	125910	52	67	42	115	77	
3/H 16L3	461.6	3.2	126360	47	67	41	114	76	
3/H 16L3	501.8	3.0	126530	44	61	38	107	72	
3/H 16L3	537.4	2.8	126380	41	63	40	109	74	
3/H 16L3	648.9	2.3	126400	34	57	36	101	68	
3/H 16L3	682.4	2.2	125660	32	58	38	101	70	
3/H 16L3	822.9	1.8	126420	27	55	35	96	65	
3/H 16L3	896.5	1.7	126420	24	51	33	91	62	
3/H 16L3	956.7	1.6	126430	23	52	33	91	62	
3/H 16L3	1160	1.3	128650	19	49	33	86	60	



3/H 17L2

$n_1 = 1800 \text{ min}^{-1}$



	i	n ₂ [min ₁]	Mn ₂ [Nm]	Pn ₁ [kW]	T _{amb} = 20°C		T _{amb} = 40°C		M ₂ Max [Nm]
					P _{TB} [kW]		P _{TFAN} [kW]		
3/H 17L2	102.4	17.6	122290	247	133	81	233	155	242000
3/H 17L2	114.5	15.7	117470	213	133	84	231	156	
3/H 17L2	129.2	13.9	121440	195	131	83	227	153	
3/H 17L2	148.6	12.1	118870	166	146	96	238	164	
3/H 17L2	168.0	10.7	131390	162	142	94	232	160	
3/H 17L2	182.7	9.9	133440	151	138	91	226	155	
3/H 17L2	216.3	8.3	139980	134	131	88	214	149	
3/H 17L2	236.3	7.6	141350	124	128	85	209	145	
3/H 17L2	259.9	6.9	129830	103	124	85	202	143	
3/H 17L2	283.5	6.3	141400	103	121	83	197	139	
3/H 17L2	336.0	5.4	146410	90	117	80	188	132	
3/H 17L2	365.4	4.9	148420	84	114	78	182	128	
3/H 17L2	412.7	4.4	151380	76	113	77	178	124	
3/H 17L2	456.8	3.9	123890	56	103	73	157	113	
3/H 17L2	540.8	3.3	134230	51	100	71	153	110	
3/H 17L2	589.6	3.1	146180	51	98	69	151	108	
3/H 17L2	659.9	2.7	135330	42	97	69	149	107	
3/H 17L2	718.7	2.7	145190	42	94	68	146	106	
3/H 17L2	851.6	2.1	147130	36	93	66	144	103	
3/H 17L2	943.4	1.9	140230	31	91	65	141	102	

3/H 17L2

$n_1 = 1500 \text{ min}^{-1}$



	i	n ₂ [min ₁]	Mn ₂ [Nm]	Pn ₁ [kW]	T _{amb} = 20°C		T _{amb} = 40°C		M ₂ Max [Nm]
					P _{TB} [kW]		P _{TFAN} [kW]		
3/H 17L2	102.4	14.7	129160	218	145	94	233	159	242000
3/H 17L2	114.5	13.1	124080	187	142	94	228	157	
3/H 17L2	129.2	11.6	128270	171	138	92	222	154	
3/H 17L2	148.6	10.1	125550	146	150	103	231	163	
3/H 17L2	168.0	8.9	138780	143	146	100	225	158	
3/H 17L2	182.7	8.2	140940	133	141	97	218	154	
3/H 17L2	216.3	6.9	141170	113	136	94	209	148	
3/H 17L2	236.3	6.3	141350	103	132	91	203	143	
3/H 17L2	259.9	5.8	137130	91	126	88	195	138	
3/H 17L2	283.5	5.3	142450	87	123	86	189	135	
3/H 17L2	336.0	4.5	146410	75	119	83	181	129	
3/H 17L2	365.4	4.1	148420	70	116	81	176	125	
3/H 17L2	412.7	3.6	151380	63	115	81	172	123	
3/H 17L2	456.8	3.3	130860	49	103	74	150	109	
3/H 17L2	540.8	2.8	141780	45	99	72	146	106	
3/H 17L2	589.6	2.5	154390	45	97	70	143	104	
3/H 17L2	659.9	2.3	142940	37	96	70	142	104	
3/H 17L2	718.7	2.1	153350	37	94	68	139	101	
3/H 17L2	851.6	1.8	155400	32	93	67	138	100	
3/H 17L2	943.4	1.6	148120	27	90	65	134	97	



3/H 17L3

$n_1 = 1800 \text{ min}^{-1}$



	i	n ₂ [min. ₁]	Mn ₂ [Nm]	Pn ₁ [kW]	T _{amb} = 20°C		T _{amb} = 40°C		M ₂ Max [Nm]
					P _{TB} [kW]		P _{TFAN} [kW]		
3/H 17L3	125.6	14.3	132010	224	80	36	167	100	242000
3/H 17L3	139.9	12.9	146990	219	82	37	167	99	
3/H 17L3	152.2	11.8	155280	211	74	34	156	94	
3/H 17L3	173.8	10.4	135960	171	82	41	160	99	
3/H 17L3	193.5	9.3	151370	169	82	41	157	96	
3/H 17L3	210.6	8.5	164730	163	74	38	147	91	
3/H 17L3	246.3	7.3	157430	141	75	39	143	89	
3/H 17L3	268.0	6.7	171320	136	68	36	133	84	
3/H 17L3	314.1	5.7	174720	115	59	34	114	74	
3/H 17L3	349.8	5.1	187210	111	59	34	113	74	
3/H 17L3	380.6	4.7	189800	103	54	31	107	70	
3/H 17L3	406.5	4.4	191850	98	56	33	108	71	
3/H 17L3	492.6	3.7	196030	82	52	31	102	68	
3/H 17L3	516.6	3.5	196570	79	53	32	102	68	
3/H 17L3	623.9	2.9	196410	65	49	30	96	64	
3/H 17L3	678.9	2.7	196620	60	46	28	92	62	
3/H 17L3	725.1	2.5	195680	56	47	29	92	62	
3/H 17L3	878.6	2.0	196640	46	46	29	88	60	
3/H 17L3	921.1	2.0	196630	44	46	29	87	59	

3/H 17L3

$n_1 = 1500 \text{ min}^{-1}$



	i	n ₂ [min ₁]	Mn ₂ [Nm]	Pn ₁ [kW]	T _{amb} = 20°C		T _{amb} = 40°C		M ₂ Max [Nm]
					P _{TB} [kW]		P _{TFAN} [kW]		
3/H 17L3	125.6	11.9	139430	197	102	56	179	112	242000
3/H 17L3	139.9	10.7	155250	193	103	56	177	111	
3/H 17L3	152.2	9.9	164010	186	91	51	163	104	
3/H 17L3	173.8	8.6	143600	151	99	57	168	108	
3/H 17L3	193.5	7.7	159880	149	98	57	164	105	
3/H 17L3	210.6	7.1	172580	141	87	51	151	98	
3/H 17L3	246.3	6.1	166280	124	88	52	147	96	
3/H 17L3	268.0	5.6	179350	116	79	47	136	89	
3/H 17L3	314.1	4.8	183970	101	67	42	115	77	
3/H 17L3	349.8	4.3	187210	92	67	41	114	76	
3/H 17L3	380.6	3.9	189800	86	61	38	107	72	
3/H 17L3	406.5	3.7	191850	81	63	40	109	74	
3/H 17L3	492.6	3.0	196030	69	57	36	101	68	
3/H 17L3	516.6	2.9	196570	66	58	38	101	70	
3/H 17L3	623.9	2.4	196410	54	55	35	96	65	
3/H 17L3	678.9	2.2	196620	50	51	33	91	62	
3/H 17L3	725.1	2.1	195680	47	52	33	91	62	
3/H 17L3	878.6	1.7	196640	39	49	33	86	60	
3/H 17L3	921.1	1.6	196630	37	50	33	86	59	

3/H 18L2

$n_1 = 1800 \text{ min}^{-1}$



	i	n ₂ [min ₁]	Mn ₂ [Nm]	Pn ₁ [kW]	T _{amb} = 20°C	T _{amb} = 40°C	T _{amb} = 20°C	T _{amb} = 40°C	M ₂ Max [Nm]
					P _{TB} [kW]		P _{TFAN} [kW]		
3/H 18L2	99.4	18.1	187480	391	274	190	434	308	322000
3/H 18L2	108.7	16.6	204660	390	267	186	424	302	
3/H 18L2	124.5	14.5	207190	345	261	182	414	294	
3/H 18L2	136.0	13.2	215320	328	255	178	404	288	
3/H 18L2	153.6	11.7	203450	274	250	175	394	281	
3/H 18L2	168.5	10.7	199340	245	227	159	367	262	
3/H 18L2	192.7	9.3	202500	218	222	155	357	254	
3/H 18L2	210.3	8.6	211520	208	216	152	347	248	
3/H 18L2	237.6	7.6	191390	167	215	152	340	244	
3/H 18L2	259.6	6.9	208930	167	210	149	331	238	
3/H 18L2	295.2	6.1	223020	156	221	156	335	240	
3/H 18L2	314.6	5.7	206400	136	195	138	285	205	
3/H 18L2	343.6	5.2	225310	136	197	141	287	207	
3/H 18L2	388.1	4.6	233090	124	193	138	282	204	
3/H 18L2	423.7	4.2	236450	116	189	135	278	200	
3/H 18L2	489.3	3.7	242060	102	180	129	267	193	
3/H 18L2	534.2	3.4	245550	95	176	126	263	190	
3/H 18L2	621.7	2.9	236170	79	166	119	251	182	
3/H 18L2	678.9	2.7	255440	78	163	116	247	178	
3/H 18L2	766.9	2.3	260670	70	159	114	242	175	
3/H 18L2	837.3	2.1	264470	65	157	113	239	173	
3/H 18L2	964.0	1.9	256940	55	147	106	227	165	

3/H 18L2

$n_1 = 1500 \text{ min}^{-1}$



	i	n ₂ [min ₁]	Mn ₂ [Nm]	Pn ₁ [kW]	T _{amb} = 20°C	T _{amb} = 40°C	T _{amb} = 20°C	T _{amb} = 40°C	M ₂ Max [Nm]
					P _{TB} [kW]		P _{TFAN} [kW]		
3/H 18L2	99.4	15.1	198020	344	278	197	419	300	322000
3/H 18L2	108.7	13.8	216170	343	271	193	409	295	
3/H 18L2	124.5	12.0	218840	303	264	188	398	286	
3/H 18L2	136.0	11.0	224700	285	257	183	388	279	
3/H 18L2	153.6	9.8	214890	242	252	180	379	273	
3/H 18L2	168.5	8.9	210550	216	229	163	352	254	
3/H 18L2	192.7	7.8	213890	192	225	161	343	248	
3/H 18L2	210.3	7.1	223410	183	220	157	335	241	
3/H 18L2	237.6	6.3	202150	147	218	156	328	237	
3/H 18L2	259.6	5.8	220680	147	213	153	319	231	
3/H 18L2	295.2	5.1	223020	130	223	160	323	234	
3/H 18L2	314.6	4.8	218000	120	197	142	276	200	
3/H 18L2	343.6	4.4	228540	115	198	143	277	201	
3/H 18L2	388.1	3.9	233090	104	193	140	271	197	
3/H 18L2	423.7	3.5	236450	96	189	137	267	194	
3/H 18L2	489.3	3.1	242060	85	180	131	257	187	
3/H 18L2	534.2	2.8	245550	79	177	129	253	185	
3/H 18L2	621.7	2.4	249450	69	167	121	242	176	
3/H 18L2	678.9	2.2	255440	65	164	119	238	173	
3/H 18L2	766.9	2.0	260670	59	160	116	233	169	
3/H 18L2	837.3	1.8	264470	55	158	115	230	168	
3/H 18L2	964.0	1.6	270740	48	147	107	217	159	



3/H 18L3

$n_1 = 1800 \text{ min}^{-1}$



	i	n ₂ [min ₁]	Mn ₂ [Nm]	Pn ₁ [kW]	T _{amb} = 20°C		T _{amb} = 40°C		M ₂ Max [Nm]
					P _{TB} [kW]		P _{TFAN} [kW]		
3/H 18L3	119.7	15.0	225040	389	140	81	282	185	322000
3/H 18L3	130.9	13.8	222420	352	138	81	276	182	
3/H 18L3	151.5	11.9	222490	304	135	81	267	178	
3/H 18L3	162.7	11.1	222340	283	143	87	272	182	
3/H 18L3	187.0	9.6	221640	246	137	85	259	175	
3/H 18L3	203.8	8.8	222300	226	138	86	257	173	
3/H 18L3	233.8	7.7	221100	196	132	83	244	165	
3/H 18L3	252.5	7.1	223180	183	88	46	196	126	
3/H 18L3	289.9	6.2	222860	159	85	45	187	120	
3/H 18L3	317.3	5.7	225590	147	88	46	196	126	
3/H 18L3	364.3	4.9	230700	131	85	45	187	120	
3/H 18L3	444.2	4.1	238260	111	99	58	184	120	
3/H 18L3	491.2	3.7	242180	102	97	57	180	118	
3/H 18L3	517.0	3.5	244260	98	117	74	199	134	
3/H 18L3	578.1	3.1	248760	89	115	73	195	132	
3/H 18L3	639.2	2.8	252900	82	111	71	189	129	
3/H 18L3	726.2	2.5	258270	74	107	69	183	125	
3/H 18L3	806.1	2.2	262830	68	106	69	180	123	
3/H 18L3	923.6	1.9	268820	60	102	66	173	118	
3/H 18L3	1025	1.8	273520	55	99	65	168	116	
3/H 18L3	1128	1.6	277930	51	96	63	163	112	

3/H 18L3

$n_1 = 1500 \text{ min}^{-1}$



	i	n ₂ [min ₁]	Mn ₂ [Nm]	Pn ₁ [kW]	T _{amb} = 20°C		T _{amb} = 40°C		M ₂ Max [Nm]
					P _{TB} [kW]	P _{TFAN} [kW]	P _{TB} [kW]	P _{TFAN} [kW]	
3/H 18L3	119.7	12.5	225040	325	159	100	283	191	322000
3/H 18L3	130.9	11.5	222420	293	155	99	276	188	
3/H 18L3	151.5	9.9	222490	254	149	96	265	181	
3/H 18L3	162.7	9.2	222340	236	158	102	271	185	
3/H 18L3	187.0	8.0	221640	205	150	98	257	177	
3/H 18L3	203.8	7.4	222300	188	150	99	254	175	
3/H 18L3	233.8	6.4	221100	163	142	94	240	166	
3/H 18L3	252.5	5.9	223180	153	105	61	200	131	
3/H 18L3	289.9	5.2	222860	133	100	59	189	125	
3/H 18L3	317.3	4.7	225590	123	105	61	200	131	
3/H 18L3	364.3	4.1	230700	109	100	59	189	125	
3/H 18L3	444.2	3.4	238260	93	110	69	184	124	
3/H 18L3	491.2	3.1	242180	85	107	68	180	122	
3/H 18L3	517.0	2.9	244260	82	124	82	196	135	
3/H 18L3	578.1	2.6	248760	74	120	80	190	132	
3/H 18L3	639.2	2.3	252900	68	116	78	185	129	
3/H 18L3	726.2	2.1	258270	61	113	75	180	124	
3/H 18L3	806.1	1.9	262830	56	111	75	176	123	
3/H 18L3	923.6	1.6	268820	50	107	72	169	118	
3/H 18L3	1025	1.5	273520	46	104	70	164	114	
3/H 18L3	1128	1.3	277930	43	99	68	157	111	



3/H 19L2

$n_1 = 1800 \text{ min}^{-1}$



	i	n ₂ [min ₁]	Mn ₂ [Nm]	Pn ₁ [kW]	T _{amb} = 20°C	T _{amb} = 40°C	T _{amb} = 20°C	T _{amb} = 40°C	M ₂ Max [Nm]
					P _{TB} [kW]		P _{TFAN} [kW]		
3/H 19L2	105.6	17.0	218430	428	281	193	461	316	480000
3/H 19L2	114.8	15.7	223990	404	274	189	448	310	
3/H 19L2	130.4	13.8	232710	370	274	190	434	308	
3/H 19L2	142.5	12.6	239000	347	267	186	424	302	
3/H 19L2	163.3	11.0	248950	316	261	182	414	294	
3/H 19L2	178.3	10.1	255600	297	255	178	404	288	
3/H 19L2	201.4	8.9	263540	271	250	175	394	281	
3/H 19L2	221.0	8.1	261410	245	227	159	367	262	
3/H 19L2	252.7	7.1	264620	217	222	155	357	254	
3/H 19L2	275.8	6.5	264380	199	216	152	347	248	
3/H 19L2	311.6	5.8	250980	167	215	152	340	244	
3/H 19L2	340.4	5.3	268180	163	210	149	331	238	
3/H 19L2	387.2	4.6	273720	146	221	156	335	240	
3/H 19L2	412.6	4.4	270660	136	195	138	285	205	
3/H 19L2	450.6	4.0	280470	129	197	141	287	207	
3/H 19L2	508.9	3.5	286000	116	193	138	282	204	
3/H 19L2	555.7	3.2	290080	108	189	135	278	200	
3/H 19L2	641.6	2.8	296970	96	180	129	267	193	
3/H 19L2	700.5	2.6	301200	89	176	126	263	190	
3/H 19L2	815.3	2.2	308770	78	166	119	251	182	
3/H 19L2	890.3	2.0	313210	73	163	116	247	178	
3/H 19L2	1006	1.8	319350	66	159	114	242	175	
3/H 19L2	1098	1.6	324250	61	157	113	239	173	

3/H 19L2

$n_1 = 1500 \text{ min}^{-1}$



	i	n ₂ [min ₁]	Mn ₂ [Nm]	Pn ₁ [kW]	T _{amb} = 20°C	T _{amb} = 40°C	T _{amb} = 20°C	T _{amb} = 40°C	M ₂ Max [Nm]
					P _{TB} [kW]		P _{TFAN} [kW]		
3/H 19L2	105.6	14.2	230770	377	287	202	433	310	480000
3/H 19L2	114.8	13.1	236650	356	280	198	424	304	
3/H 19L2	130.4	11.5	245860	325	278	197	419	300	
3/H 19L2	142.5	10.5	252500	306	271	193	409	295	
3/H 19L2	163.3	9.2	263020	278	264	188	398	286	
3/H 19L2	178.3	8.4	264670	256	257	183	388	279	
3/H 19L2	201.4	7.4	263540	226	252	180	379	273	
3/H 19L2	221.0	6.8	264980	207	229	163	352	254	
3/H 19L2	252.7	5.9	264620	181	225	161	343	248	
3/H 19L2	275.8	5.4	264380	165	220	157	335	241	
3/H 19L2	311.6	4.8	264480	147	218	156	328	237	
3/H 19L2	340.4	4.4	268180	136	213	153	319	231	
3/H 19L2	387.2	3.9	273720	122	223	160	323	234	
3/H 19L2	412.6	3.6	276510	116	197	142	276	200	
3/H 19L2	450.6	3.3	280470	107	198	143	277	201	
3/H 19L2	508.9	2.9	286000	97	193	140	271	197	
3/H 19L2	555.7	2.7	290080	90	189	137	267	194	
3/H 19L2	641.6	2.3	296970	80	180	131	257	187	
3/H 19L2	700.5	2.1	301200	74	177	129	253	185	
3/H 19L2	815.3	1.8	308770	65	167	121	242	176	
3/H 19L2	890.3	1.7	313210	61	164	119	238	173	
3/H 19L2	1006	1.5	319350	55	160	116	233	169	
3/H 19L2	1098	1.4	324250	51	158	115	230	168	



3/H 19L3

$n_1 = 1800 \text{ min}^{-1}$



	i	n ₂ [min. ₁]	Mn ₂ [Nm]	Pn ₁ [kW]	T _{amb} = 20°C		T _{amb} = 40°C		M ₂ Max [Nm]
					P _{TB} [kW]		P _{TFAN} [kW]		
3/H 19L3	132.5	13.6	237260	371	140	81	282	185	480000
3/H 19L3	144.9	12.4	243720	348	138	81	276	182	
3/H 19L3	167.7	10.7	254630	315	135	81	267	178	
3/H 19L3	180.1	10.0	260150	299	143	87	272	182	
3/H 19L3	207.0	8.7	271250	271	137	85	259	175	
3/H 19L3	225.6	8.0	278350	256	138	86	257	173	
3/H 19L3	258.8	7.0	290030	232	132	83	244	165	
3/H 19L3	279.5	6.4	296800	220	88	46	196	126	
3/H 19L3	320.9	5.6	309360	200	85	45	187	120	
3/H 19L3	391.2	4.6	328330	174	99	58	184	120	
3/H 19L3	432.6	4.2	338390	162	97	57	180	118	
3/H 19L3	455.4	4.0	343640	156	117	74	199	134	
3/H 19L3	509.2	3.5	355350	145	115	73	195	132	
3/H 19L3	563.0	3.2	366220	135	111	71	189	129	
3/H 19L3	639.6	2.8	377240	122	107	69	183	125	
3/H 19L3	710.0	2.5	392610	115	106	69	180	123	
3/H 19L3	813.5	2.2	394420	100	102	66	173	118	
3/H 19L3	902.5	2.0	420950	97	99	65	168	116	
3/H 19L3	993.6	1.8	430230	90	96	63	163	112	

3/H 19L3

$n_1 = 1500 \text{ min}^{-1}$



	i	n ₂ [min ₁]	Mn ₂ [Nm]	Pn ₁ [kW]	T _{amb} = 20°C		T _{amb} = 40°C		M ₂ Max [Nm]
					P _{TB} [kW]	P _{TFAN} [kW]	P _{TB} [kW]	P _{TFAN} [kW]	
3/H 19L3	132.5	11.3	250820	327	159	100	283	191	480000
3/H 19L3	144.9	10.4	257660	307	155	99	276	188	
3/H 19L3	167.7	8.9	269190	277	149	96	265	181	
3/H 19L3	180.1	8.3	275020	264	158	102	271	185	
3/H 19L3	207.0	7.2	286760	239	150	98	257	177	
3/H 19L3	225.6	6.6	294270	225	150	99	254	175	
3/H 19L3	258.8	5.8	306610	205	142	94	240	166	
3/H 19L3	279.5	5.4	313770	194	105	61	200	131	
3/H 19L3	320.9	4.7	327050	176	100	59	189	125	
3/H 19L3	391.2	3.8	347100	153	110	69	184	124	
3/H 19L3	432.6	3.5	357730	143	107	68	180	122	
3/H 19L3	455.4	3.3	363280	138	124	82	196	135	
3/H 19L3	509.2	2.9	375660	127	120	80	190	132	
3/H 19L3	563.0	2.7	387150	119	116	78	185	129	
3/H 19L3	639.6	2.3	398450	108	113	75	180	124	
3/H 19L3	710.0	2.1	415050	101	111	75	176	123	
3/H 19L3	813.5	1.8	416600	88	107	72	169	118	
3/H 19L3	902.5	1.7	437630	84	104	70	164	114	
3/H 19L3	993.6	1.5	437660	76	99	68	157	111	



3/H 21L3

$n_1 = 1800 \text{ min}^{-1}$



	i	n ₂ [min ₁]	Mn ₂ [Nm]	Pn ₁ [kW]	T _{amb} = 20°C	T _{amb} = 40°C	T _{amb} = 20°C	T _{amb} = 40°C	M ₂ Max [Nm]
					P _{TB} [kW]		P _{TFAN} [kW]		
3/H 21L3	120.1	15.0	310570	536	180	105	347	228	720000
3/H 21L3	131.0	13.7	318780	504	178	105	341	225	
3/H 21L3	153.8	11.7	334600	451	180	105	347	228	
3/H 21L3	167.8	10.7	343450	424	178	105	341	225	
3/H 21L3	188.7	9.5	355800	391	181	109	338	224	
3/H 21L3	207.4	8.7	366000	366	190	118	342	230	
3/H 21L3	233.0	7.7	379020	337	188	117	334	224	
3/H 21L3	258.6	7.0	391070	313	183	115	323	218	
3/H 21L3	291.3	6.2	405260	288	182	116	315	214	
3/H 21L3	319.2	5.6	416560	270	168	108	296	202	
3/H 21L3	361.2	5.0	432280	248	165	106	286	195	
3/H 21L3	403.1	4.5	446760	230	134	82	236	157	
3/H 21L3	454.4	4.0	463100	211	133	81	233	155	
3/H 21L3	507.9	3.5	478850	195	133	84	231	156	
3/H 21L3	573.2	3.1	496530	179	131	83	227	153	
3/H 21L3	659.4	2.7	511250	161	128	96	238	164	
3/H 21L3	745.6	2.4	537290	149	124	94	232	160	
3/H 21L3	810.8	2.2	550980	141	121	91	226	155	
3/H 21L3	960.0	1.9	579610	125	117	88	214	149	

3/H 21L3

$n_1 = 1500 \text{ min}^{-1}$



	i	n ₂ [min. ₁]	Mn ₂ [Nm]	Pn ₁ [kW]	T _{amb} = 20°C	T _{amb} = 40°C	T _{amb} = 20°C	T _{amb} = 40°C	M ₂ Max [Nm]
					P _{TB} [kW]		P _{TFAN} [kW]		
3/H 21L3	120.1	12.5	328030	471	204	129	350	237	720000
3/H 21L3	131.0	11.4	336710	444	200	127	343	232	
3/H 21L3	153.8	9.8	352870	396	204	129	350	237	
3/H 21L3	167.8	8.9	362200	373	200	127	343	232	
3/H 21L3	188.7	7.9	375230	343	200	129	338	230	
3/H 21L3	207.4	7.2	385980	321	207	136	340	234	
3/H 21L3	233.0	6.4	399720	296	203	134	331	228	
3/H 21L3	258.6	5.8	412430	275	196	130	319	220	
3/H 21L3	291.3	5.2	427390	253	195	130	312	216	
3/H 21L3	319.2	4.7	439310	238	179	120	291	203	
3/H 21L3	361.2	4.2	455880	218	176	117	282	195	
3/H 21L3	403.1	3.7	471160	202	146	95	236	161	
3/H 21L3	454.4	3.3	488390	186	145	94	233	159	
3/H 21L3	507.9	3.0	505000	172	142	94	228	157	
3/H 21L3	573.2	2.6	523640	158	138	92	222	154	
3/H 21L3	659.4	2.3	539990	141	150	103	231	163	
3/H 21L3	745.6	2.0	566630	131	146	100	225	158	
3/H 21L3	810.8	1.8	581070	124	141	97	218	154	
3/H 21L3	960.0	1.6	605930	109	136	94	209	148	



3/H 23L3

$n_1 = 1800 \text{ min}^{-1}$



	i	n ₂ [min. ₁]	Mn ₂ [Nm]	Pn ₁ [kW]	T _{amb} = 20°C	T _{amb} = 40°C	T _{amb} = 20°C	T _{amb} = 40°C	M ₂ Max [Nm]
					P _{TB} [kW]		P _{TFAN} [kW]		
3/H 23L3	121.5	14.8	551670	940	267	144	546	349	1500000
3/H 23L3	139.2	12.9	574570	855	287	161	554	359	
3/H 23L3	150.9	11.9	588730	808	282	165	554	358	
3/H 23L3	172.5	10.4	612790	736	301	178	552	363	
3/H 23L3	188.2	9.6	629000	692	273	166	516	345	
3/H 23L3	215.6	8.3	655210	692	298	184	530	354	
3/H 23L3	235.2	7.7	672540	592	255	161	479	326	
3/H 23L3	266.6	6.8	698280	543	271	169	483	325	
3/H 23L3	297.9	6.0	721970	502	289	197	461	323	
3/H 23L3	358.7	5.0	763310	441	281	193	448	316	
3/H 23L3	390.0	4.6	782750	416	274	189	438	310	
3/H 23L3	443.0	4.1	809320	378	274	190	434	308	
3/H 23L3	484.1	3.7	821670	352	267	186	424	302	
3/H 23L3	554.7	3.2	821830	307	261	182	414	294	
3/H 23L3	605.6	3.0	821980	281	255	178	404	288	
3/H 23L3	684.0	2.6	822130	249	250	175	394	281	
3/H 23L3	750.7	2.4	822200	227	227	159	367	262	
3/H 23L3	858.5	2.1	822260	198	222	155	357	254	
3/H 23L3	936.9	1.9	822380	182	216	152	347	248	

3/H 23L3

$n_1 = 1500 \text{ min}^{-1}$



	i	n ₂ [min ⁻¹]	Mn ₂ [Nm]	Pn ₁ [kW]	T _{amb} = 20°C	T _{amb} = 40°C	T _{amb} = 20°C	T _{amb} = 40°C	M ₂ Max [Nm]
					P _{TB} [kW]		P _{TFAN} [kW]		
3/H 23L3	121.5	12.3	583160	828	304	190	549	370	1500000
3/H 23L3	139.2	10.8	607360	753	327	206	463	380	
3/H 23L3	150.9	9.9	622330	712	315	202	545	371	
3/H 23L3	172.5	8.7	647760	648	337	214	558	376	
3/H 23L3	188.2	8.0	664900	610	300	193	513	350	
3/H 23L3	215.6	7.0	692610	555	326	211	529	360	
3/H 23L3	235.2	6.4	710930	522	277	182	473	326	
3/H 23L3	266.6	5.6	738130	478	294	192	480	329	
3/H 23L3	297.9	5.0	763180	442	297	208	448	319	
3/H 23L3	358.7	4.2	806880	388	287	202	433	310	
3/H 23L3	390.0	3.8	821300	363	280	198	424	304	
3/H 23L3	443.0	3.4	821540	320	278	197	419	300	
3/H 23L3	484.1	3.1	821670	293	271	193	409	295	
3/H 23L3	554.7	2.7	821830	256	264	188	398	286	
3/H 23L3	605.6	2.5	821980	234	257	183	388	279	
3/H 23L3	684.0	2.2	822130	207	252	180	379	273	
3/H 23L3	750.7	2.0	822200	189	229	163	352	254	
3/H 23L3	858.5	1.7	822260	165	225	161	343	248	
3/H 23L3	936.9	1.6	822380	152	220	157	335	241	

3/H 25L3

$n_1 = 1800 \text{ min}^{-1}$



	i	n ₂ [min ₁]	Mn ₂ [Nm]	Pn ₁ [kW]	T _{amb} = 20°C	T _{amb} = 40°C	T _{amb} = 20°C	T _{amb} = 40°C	M ₂ Max [Nm]
					P _{TB} [kW]		P _{TFAN} [kW]		
3/H 25L3	127.7	14.1	637420	1034	269	141	554	351	1725000
3/H 25L3	138.9	13.0	660140	985	267	144	546	349	
3/H 25L3	159.0	11.3	683840	891	287	161	556	359	
3/H 25L3	172.5	10.4	707890	850	282	165	554	358	
3/H 25L3	197.1	9.1	732910	770	301	178	552	363	
3/H 25L3	215.0	8.4	742730	715	273	166	516	345	
3/H 25L3	246.4	7.3	770290	648	298	184	530	354	
3/H 25L3	268.8	6.7	780780	602	255	161	479	326	
3/H 25L3	304.6	5.9	810830	551	271	169	483	325	
3/H 25L3	340.5	5.3	850670	518	289	197	461	323	
3/H 25L3	409.9	4.4	879150	444	281	193	448	316	
3/H 25L3	445.8	4.0	959720	446	274	189	438	310	
3/H 25L3	506.2	3.6	924940	378	274	190	434	308	
3/H 25L3	553.3	3.3	1009700	378	267	186	424	302	
3/H 25L3	633.9	2.8	1022180	334	261	182	414	294	
3/H 25L3	692.2	2.6	1062270	318	255	178	404	288	
3/H 25L3	781.8	2.3	1003750	266	250	175	394	281	
3/H 25L3	857.9	2.1	983460	237	227	159	367	262	
3/H 25L3	981.1	1.8	999070	211	222	155	357	254	
3/H 25L3	1071	1.7	1043550	202	216	152	347	248	

3/H 25L3

$n_1 = 1500 \text{ min}^{-1}$



	i	n ₂ [min ₁]	Mn ₂ [Nm]	Pn ₁ [kW]	T _{amb} = 20°C	T _{amb} = 40°C	T _{amb} = 20°C	T _{amb} = 40°C	M ₂ Max [Nm]
					P _{TB} [kW]		P _{TFAN} [kW]		
3/H 25L3	127.7	11.7	673260	910	309	191	559	375	1725000
3/H 25L3	138.9	10.8	697260	867	304	190	549	370	
3/H 25L3	159.0	9.4	722290	784	327	206	463	380	
3/H 25L3	172.5	8.7	747690	748	315	202	545	371	
3/H 25L3	197.1	7.6	774110	678	337	214	558	376	
3/H 25L3	215.0	7.0	784490	630	300	193	513	350	
3/H 25L3	246.4	6.1	813600	570	326	211	529	360	
3/H 25L3	268.8	5.6	824670	530	277	182	473	326	
3/H 25L3	304.6	4.9	856420	485	294	192	480	329	
3/H 25L3	340.5	4.4	898490	456	297	208	448	319	
3/H 25L3	409.9	3.7	928580	391	287	202	433	310	
3/H 25L3	445.8	3.4	1013670	393	280	198	424	304	
3/H 25L3	506.2	3.0	976940	333	278	197	419	300	
3/H 25L3	553.3	2.7	1066470	333	271	193	409	295	
3/H 25L3	633.9	2.4	1079650	294	264	188	398	286	
3/H 25L3	692.2	2.2	1121990	280	257	183	388	279	
3/H 25L3	781.8	1.9	1060180	234	252	180	379	273	
3/H 25L3	857.9	1.7	1038750	209	229	163	352	254	
3/H 25L3	981.1	1.5	1055240	186	225	161	343	248	
3/H 25L3	1071	1.4	1102220	178	220	157	335	241	



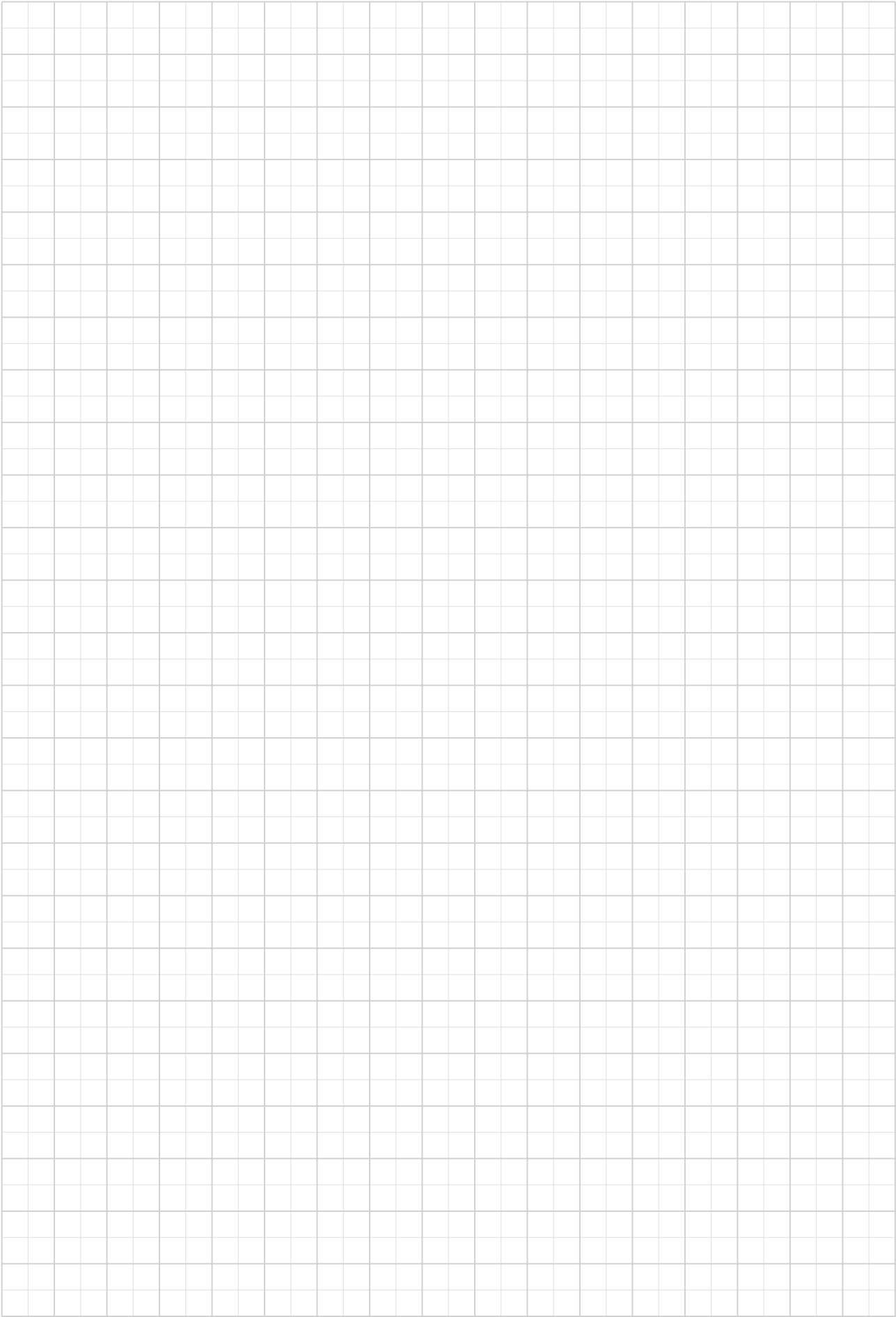

18. MOMENT OF INERTIA

The moments of inertia refer to the input shaft of the gear unit and only to the configuration characterised by a solid input shaft and an output with shrink disk mounted (FP/G0A).

3/H 11L2 $J \cdot 10^{-4}$		3/H 13L2 $J \cdot 10^{-4}$		3/H 15L2 $J \cdot 10^{-4}$		3/H 15L3 $J \cdot 10^{-4}$		3/H 16L2 $J \cdot 10^{-4}$		3/H 16L3 $J \cdot 10^{-4}$		3/H 17L2 $J \cdot 10^{-4}$		3/H 17L3 $J \cdot 10^{-4}$	
i =	[kg m ²]	i =	[kg m ²]	i =	[kg m ²]	i =	[kg m ²]	i =	[kg m ²]	i =	[kg m ²]	i =	[kg m ²]	i =	[kg m ²]
30.3	986	30.6	992	93.5	551	128.8	984	111.4	841	128.8	988	102.4	1219	125.6	1000
33.9	947	34.4	953	104.6	494	144.4	946	117.3	551	144.4	949	114.5	1024	139.9	958
36.8	924	37.3	928	115.6	488	156.6	923	131.1	495	156.6	925	129.2	926	152.2	933
42.1	633	42.6	636	131.3	488	179.2	632	145.0	489	179.2	634	148.6	599	173.8	640
47.0	613	47.6	616	145.8	444	200.1	613	164.7	449	200.1	614	168.0	540	193.5	619
51.1	601	51.8	604	167.0	418	217.5	601	182.8	445	217.5	602	182.7	534	210.6	606
59.7	435	60.4	437	185.3	415	254.0	435	209.5	418	254.0	436	216.3	467	246.3	439
65.0	427	65.8	429	204.0	242	276.7	427	232.4	415	276.7	428	236.3	464	268.0	430
76.0	416	77.0	418	225.7	241	278.8	559	255.8	242	278.8	600	259.9	280	314.1	418
84.6	410	85.7	411	259.3	230	325.6	433	283.0	241	325.6	434	283.5	278	349.8	411
92.1	407	93.2	407	286.9	229	354.6	426	325.1	230	354.6	426	336.0	250	380.6	407
98.6	375	99.8	376	329.0	169	414.8	416	359.8	229	414.8	416	365.4	249	406.5	376
119.0	369	120.5	369	364.2	168	461.6	409	413.1	227	461.6	409	412.7	247	492.6	369
125.2	351	126.7	351	411.0	143	501.8	406	456.8	168	501.8	406	456.8	183	516.6	351
150.9	180	152.8	180	462.8	163	537.4	375	515.4	143	537.4	375	540.8	172	623.9	180
164.4	179	166.4	179	517.2	140	648.9	369	580.4	163	648.9	369	589.6	171	678.9	179
175.5	169	177.6	170	582.7	70	682.4	351	648.7	140	682.4	351	659.9	145	725.1	170
212.7	167	215.3	167	657.5	60	822.9	179	730.7	70	822.9	179	718.7	145	878.6	167
222.9	161	225.6	161	740.8	68	896.5	178	824.6	60	896.5	178	851.6	141	921.1	161
248.3	161	251.3	161	827.5	59	956.7	169	929.0	68	956.7	169	943.4	71	-	-
270.3	161	273.7	161	916.7	59	1160	167	1038	59	1160	167	-	-	-	-
335.4	66	339.5	66	1039	56	-	-	1150	59	-	-	-	-	-	-
373.4	66	378.0	66	-	-	-	-	-	-	-	-	-	-	-	-
389.8	74	394.5	74	-	-	-	-	-	-	-	-	-	-	-	-
483.0	65	488.9	65	-	-	-	-	-	-	-	-	-	-	-	-
525.6	64	532.0	64	-	-	-	-	-	-	-	-	-	-	-	-
560.7	61	567.6	61	-	-	-	-	-	-	-	-	-	-	-	-
651.5	60	659.5	60	-	-	-	-	-	-	-	-	-	-	-	-
725.6	60	734.4	60	-	-	-	-	-	-	-	-	-	-	-	-
828.2	60	838.4	60	-	-	-	-	-	-	-	-	-	-	-	-
921.9	60	933.2	60	-	-	-	-	-	-	-	-	-	-	-	-
1048	30	1061	30	-	-	-	-	-	-	-	-	-	-	-	-
1099	30	1113	30	-	-	-	-	-	-	-	-	-	-	-	-



Dimensions and weights



19. DIMENSIONS AND WEIGHTS

3/H 11L2

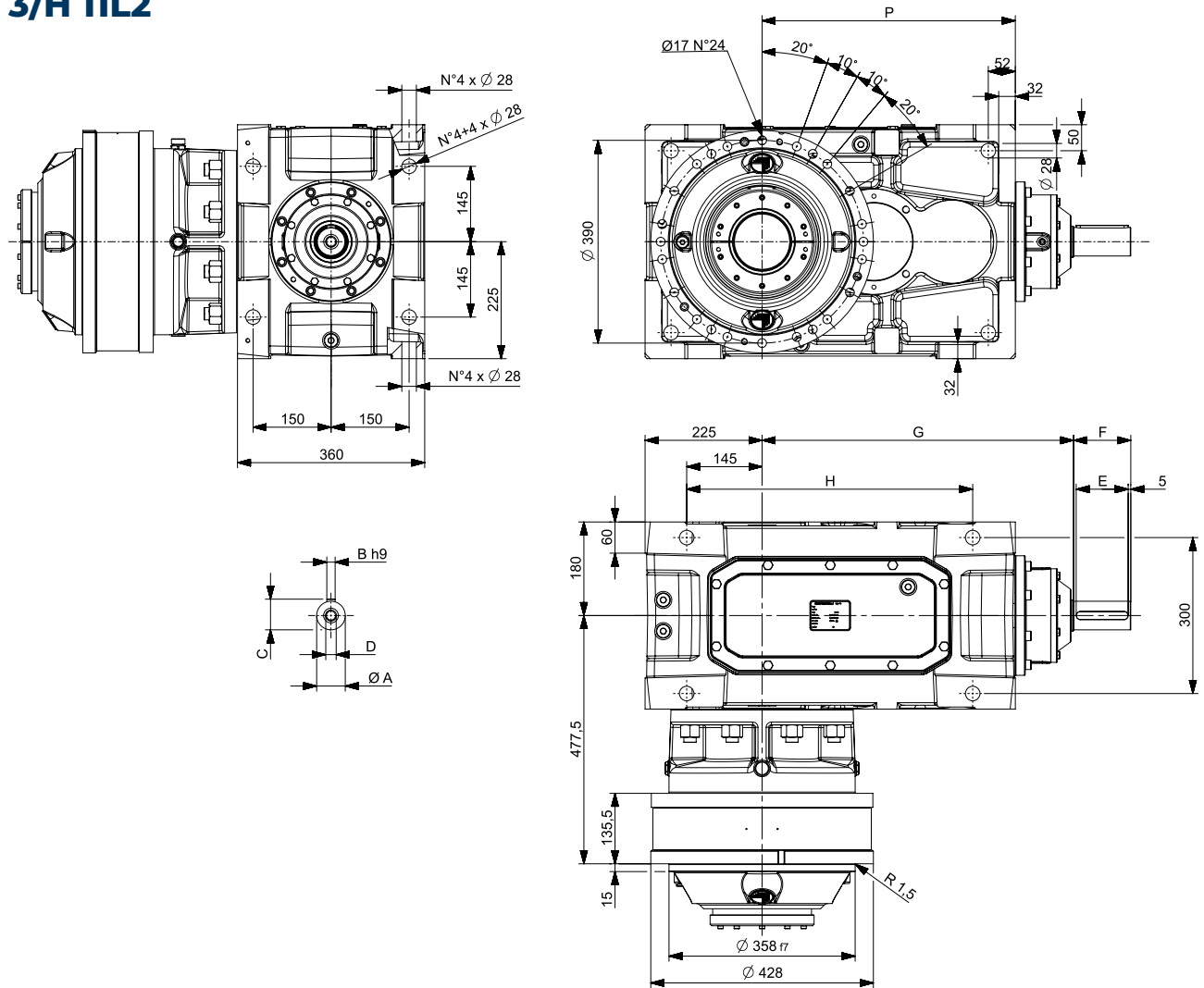

VP	i =	A [mm]	B [mm]	C [mm]	D [mm]	E [mm]	F [mm]	G [mm]	H [mm]	P [mm]	FP [KG]
3/H 11L2	30.3 65.0	55 m6	16	59	M20x42	100	110	599	405	487	665
3/H 11L2	76.0 270.3	45 k6	14	48.5	M16x36	100	110	706	525	605	726
3/H 11L2	335.4 1099	32 k6	10	35	M12x28	70	80	711	525	605	731

3/H 11L2

FZP

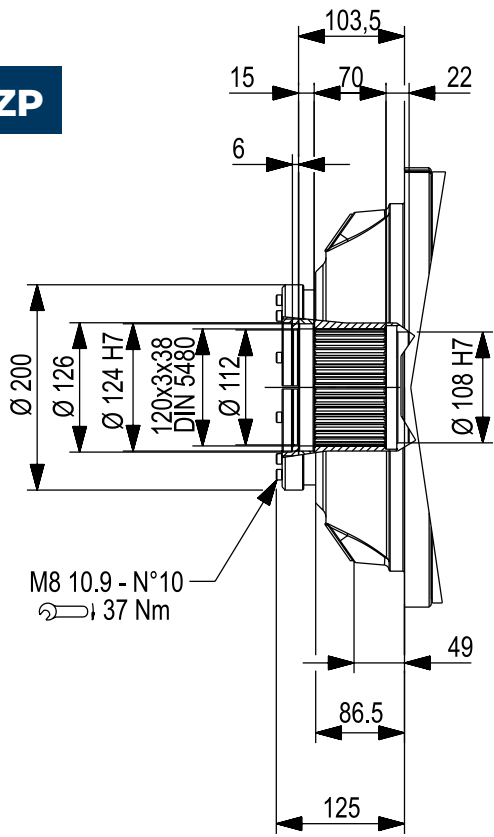

FP

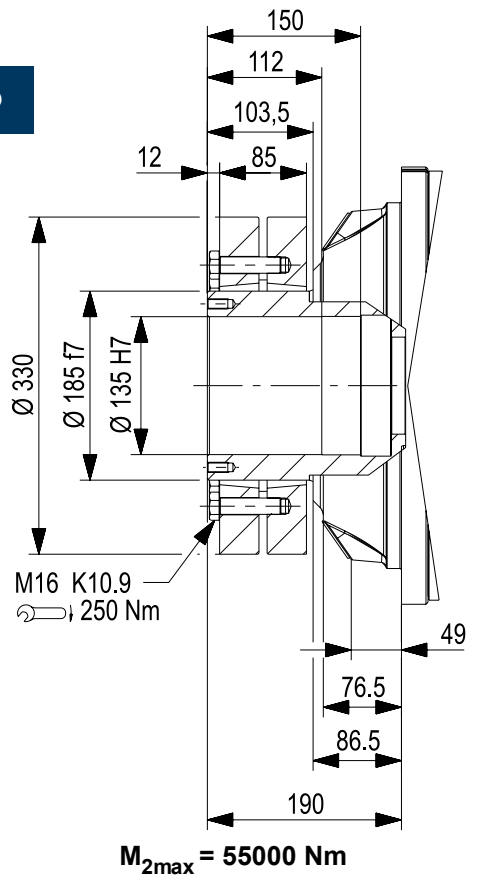

3/H 13L2

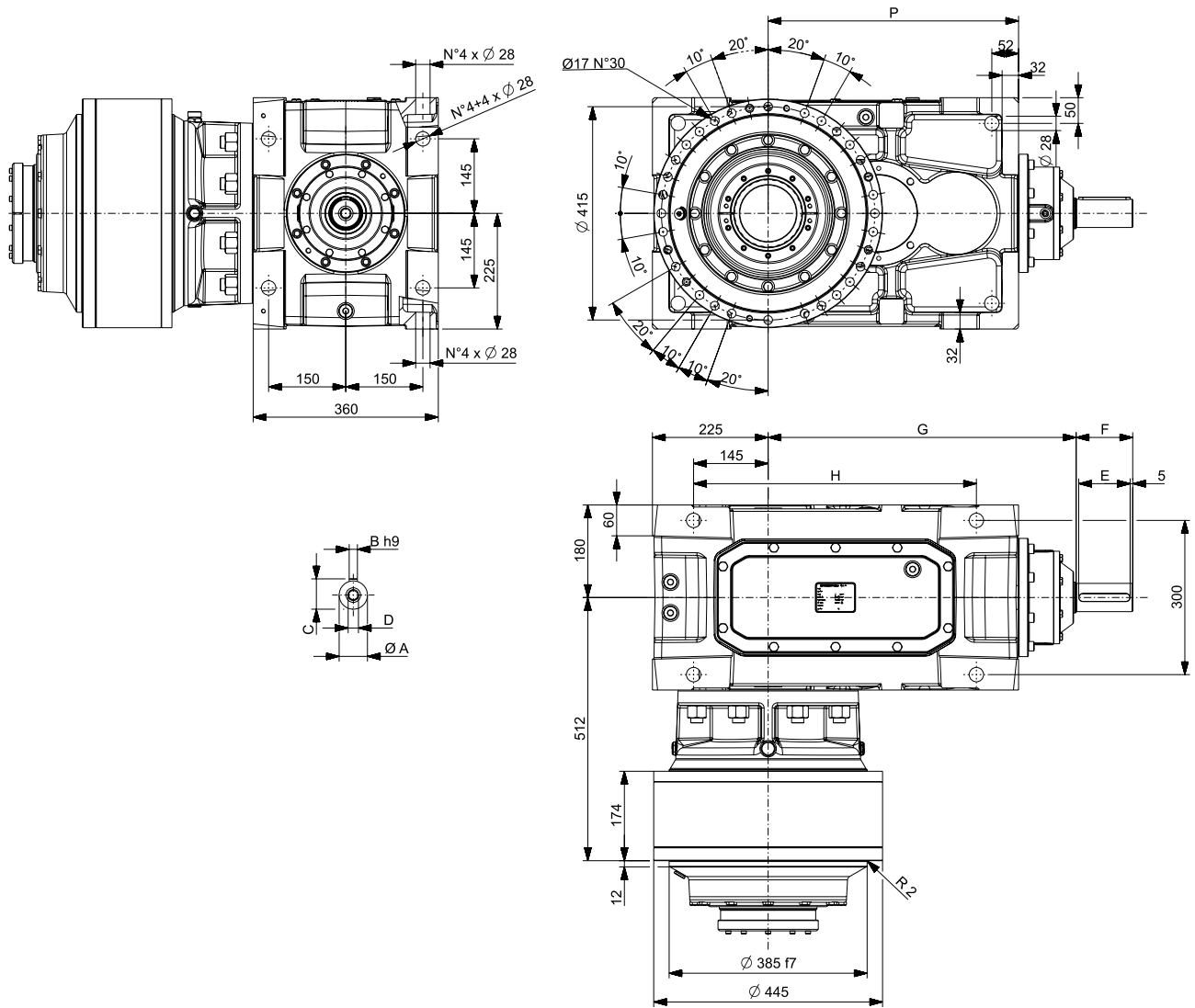

VP	i =	A [mm]	B [mm]	C [mm]	D [mm]	E [mm]	F [mm]	G [mm]	H [mm]	P [mm]	FP [KG]
3/H 13L2	30.6 65.8	55 m6	16	59	M20x42	100	110	599	405	487	718
3/H 13L2	77.0 273.7	45 k6	14	48.5	M16x36	100	110	706	525	605	778
3/H 13L2	339.5 1113	32 k6	10	35	M12x28	70	80	711	525	605	783

3/H 13L2

FZP

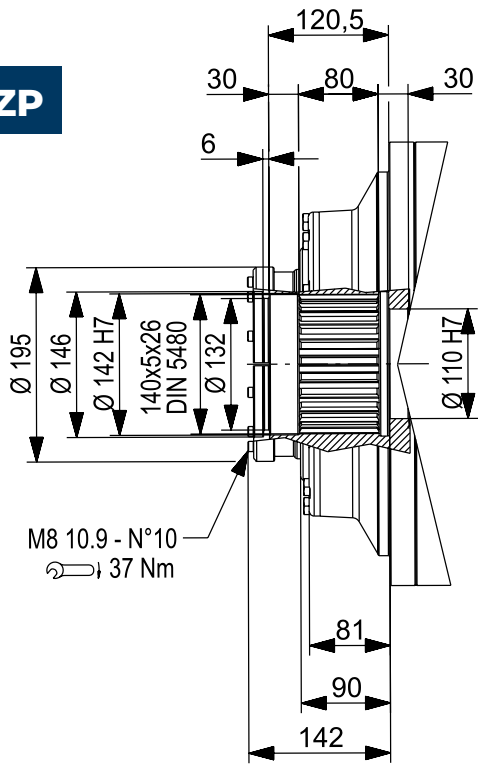

FP

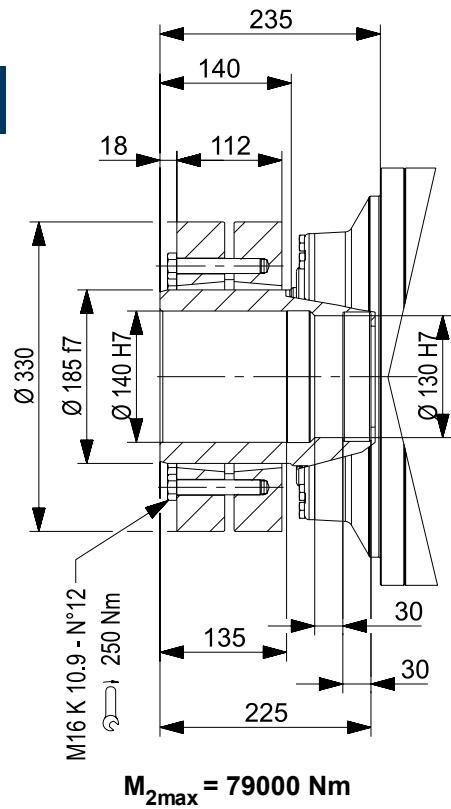

3/H 15L2

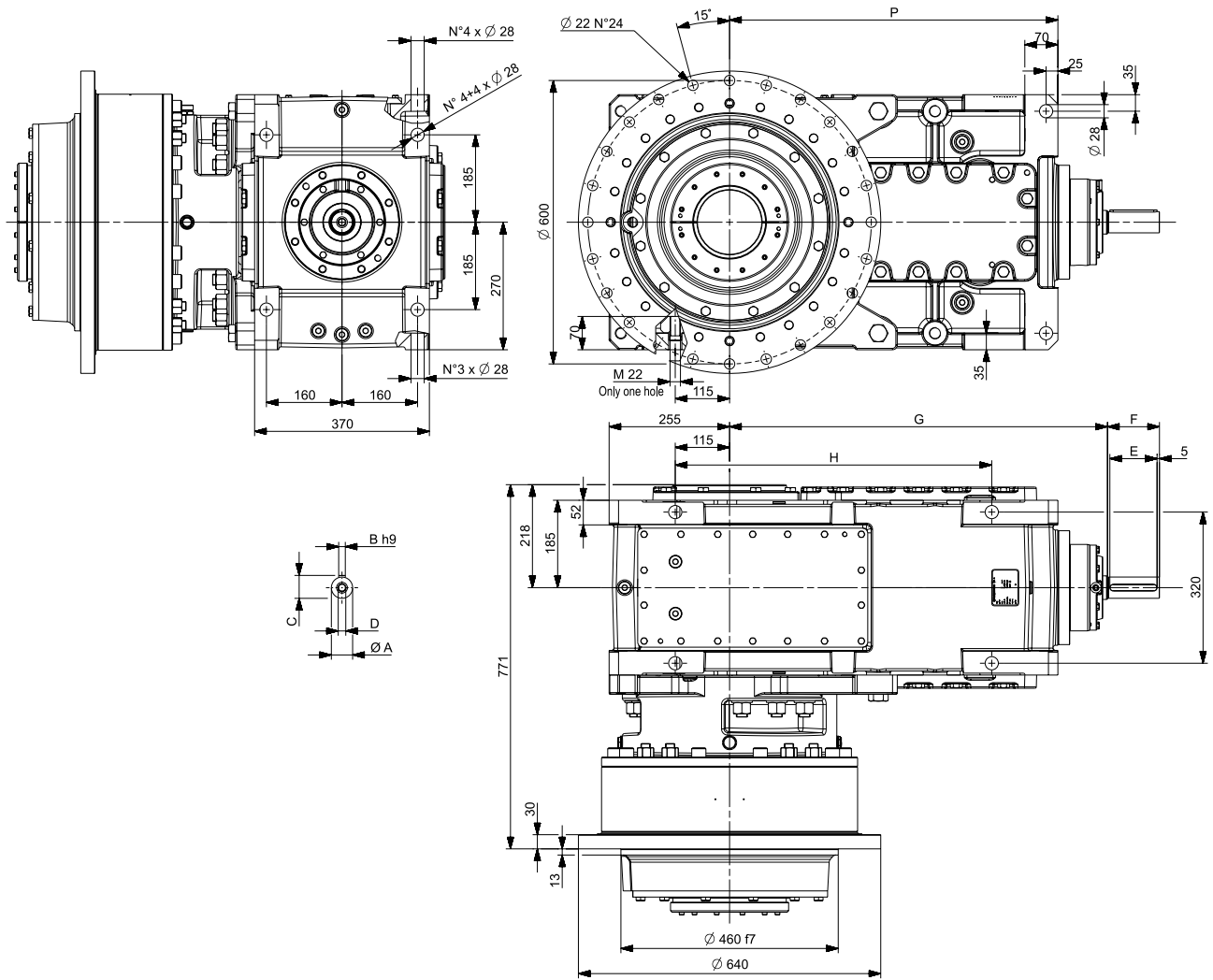

VP	i =	A [mm]	B [mm]	C [mm]	D [mm]	E [mm]	F [mm]	G [mm]	H [mm]	P [mm]	FP [KG]
3/H 15L2	93.5 286.9	45 k6	14	48.5	M16x36	100	110	800	670	695	1318
3/H 15L2	329.0 517.2	35 k6	10	38	M12x28	70	80	800	670	695	1313
3/H 15L2	582.7 1039	32 k6	10	35	M12x28	70	80	800	670	695	1313

3/H 15L3

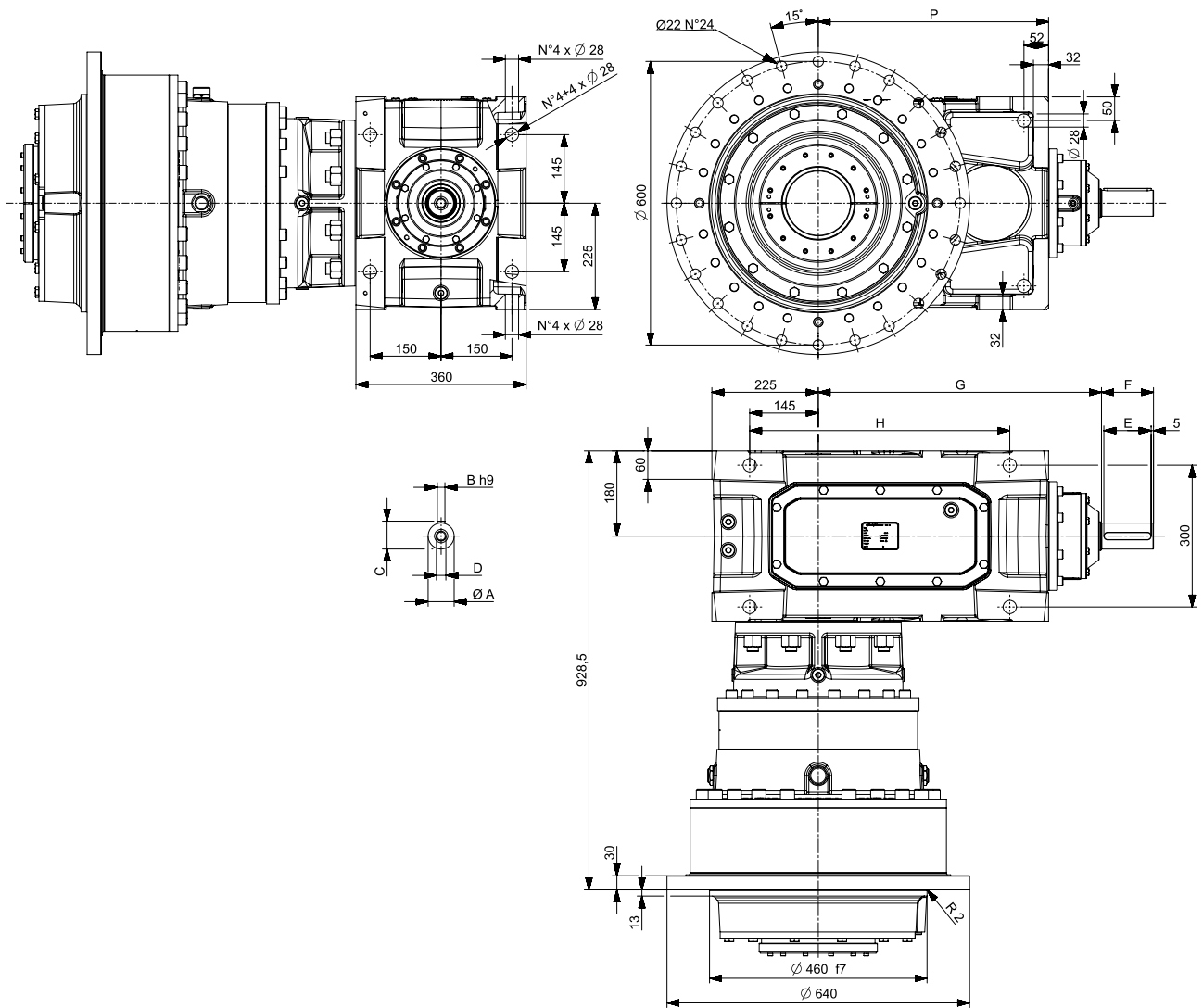

VP	i =	A [mm]	B [mm]	C [mm]	D [mm]	E [mm]	F [mm]	G [mm]	H [mm]	P [mm]	FP [KG]
3/H 15L3	128.8 354.6	55 m6	16	59	M20x42	100	110	599	405	487	1180
3/H 15L3	414.8 1160	45 k6	14	48.5	M16x36	100	110	706	525	605	1240

3/H 15L2 - 15L3

FZP

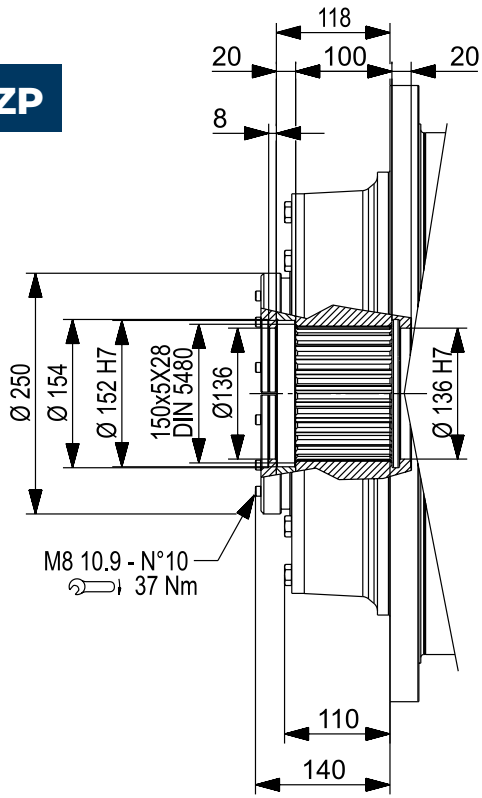

FP

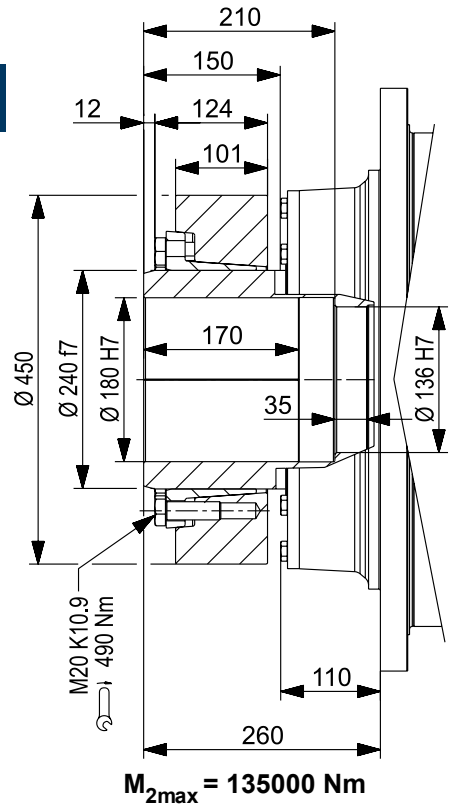

3/H 16L2

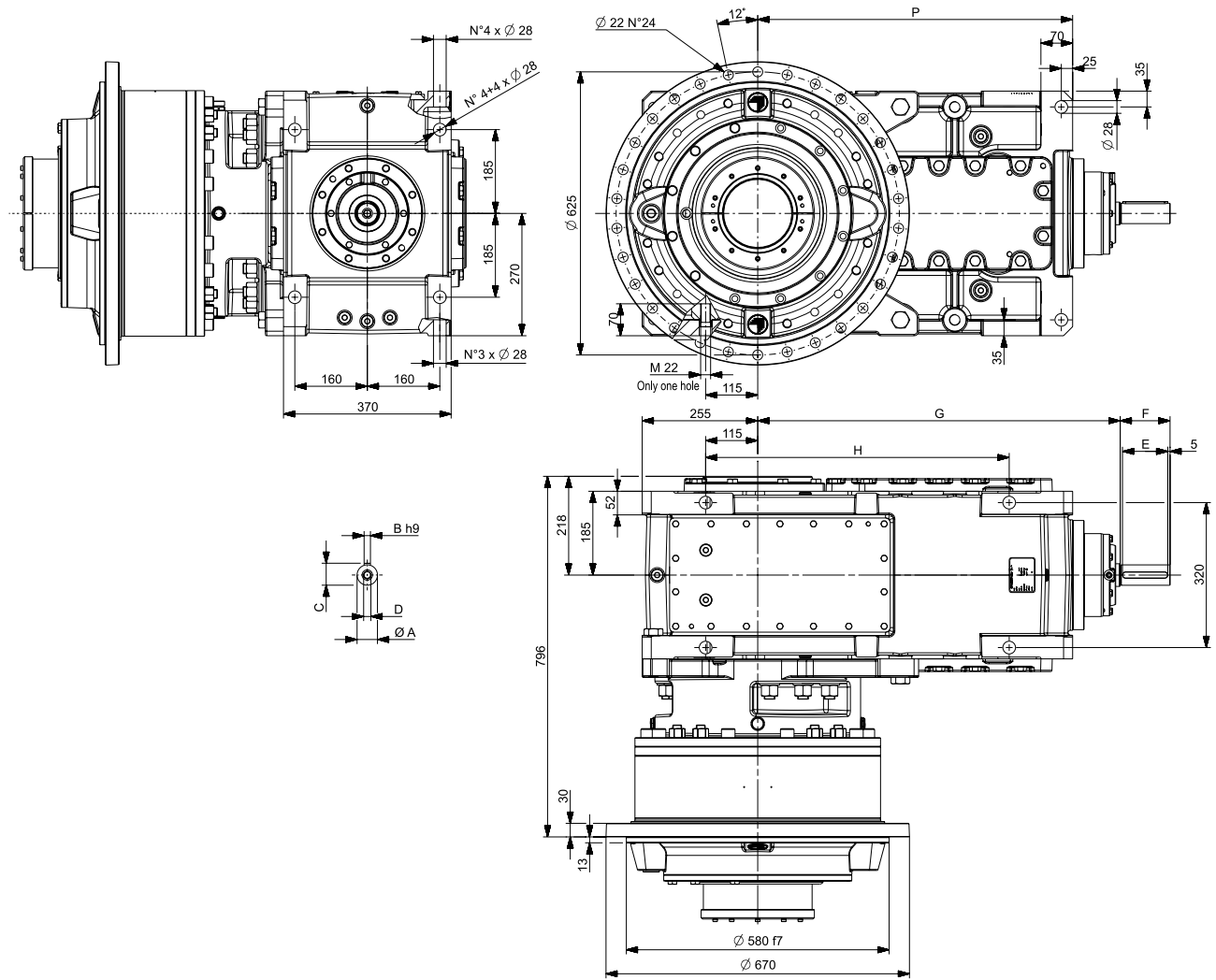

VP	i =	A [mm]	B [mm]	C [mm]	D [mm]	E [mm]	F [mm]	G [mm]	H [mm]	P [mm]	FP [KG]
3/H 16L2	111.4	55 m6	16	59	M20x42	100	110	800	670	695	1470
3/H 16L2	117.3 413.1	45 k6	14	48.5	M16x36	100	110	800	670	695	1470
3/H 16L2	456.8 648.7	35 k6	10	38	M12x28	70	80	800	670	695	1465
3/H 16L2	730.7 1150	32 k6	10	35	M12x28	70	80	800	670	695	1465

3/H 16L3

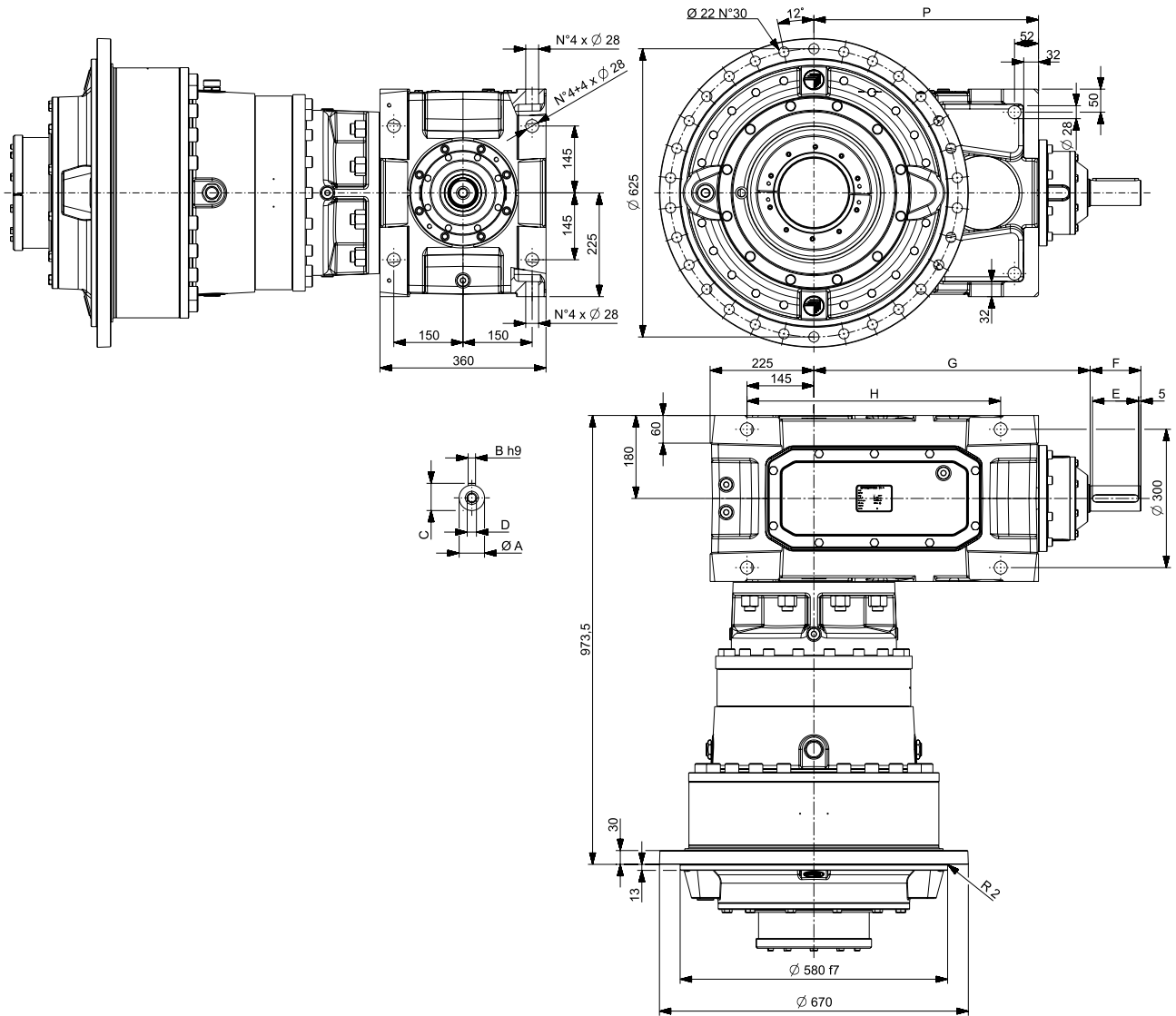

VP	i =	A [mm]	B [mm]	C [mm]	D [mm]	E [mm]	F [mm]	G [mm]	H [mm]	P [mm]	FP [KG]
3/H 16L3	128.8 354.6	55 m6	16	59	M20x42	100	110	599	405	487	1200
3/H 16L3	414.8 1160	45 k6	14	48.5	M16x36	100	110	706	525	605	1260

3/H 16L2 - 16L3

FZP

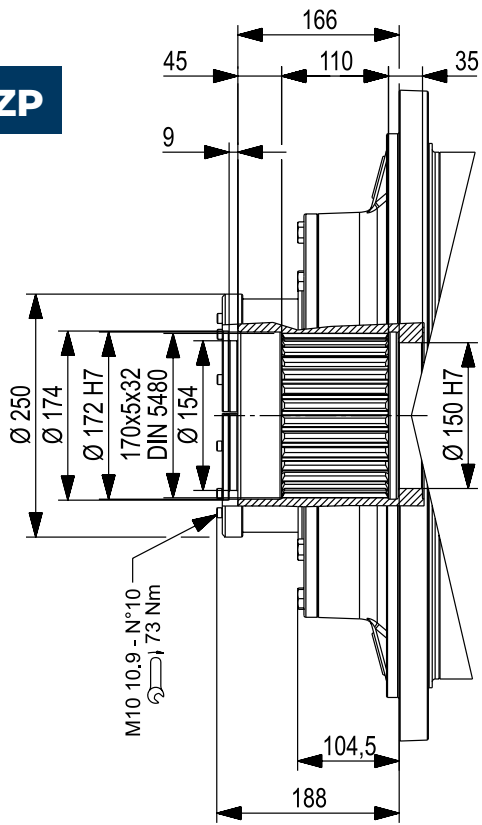

FP

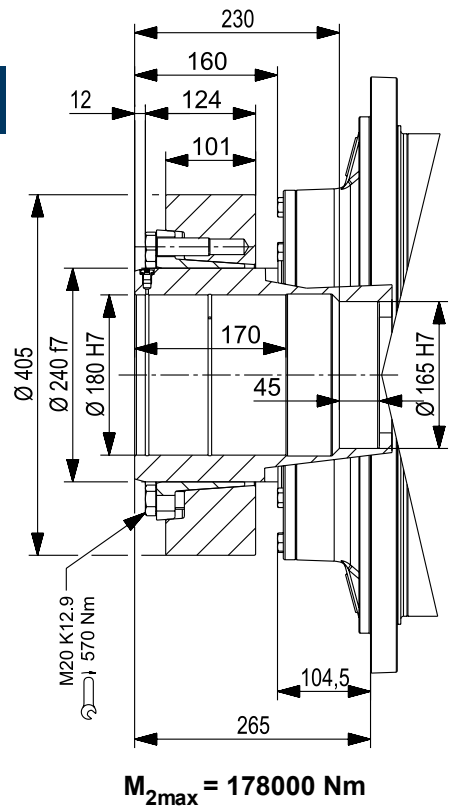

3/H 17L3

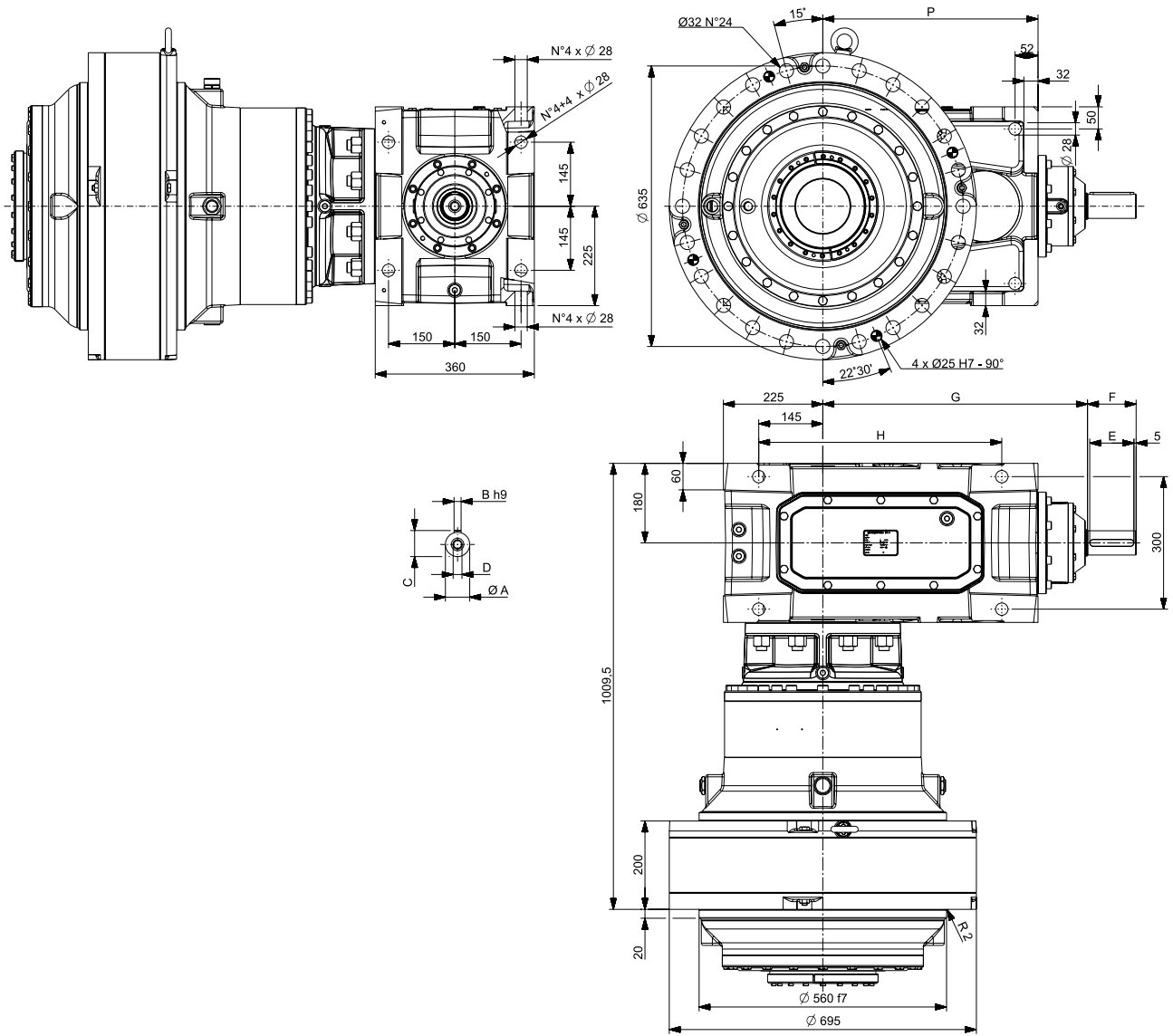

VP	i =	A [mm]	B [mm]	C [mm]	D [mm]	E [mm]	F [mm]	G [mm]	H [mm]	P [mm]	FP [KG]
3/H 17L3	125.6 268.0	55 m6	16	59	M20x42	100	110	599	405	487	1835
3/H 17L3	314.1 921.1	45 k6	14	48.5	M16x36	100	110	706	525	605	1895

3/H 17L2 - 17L3

FZP

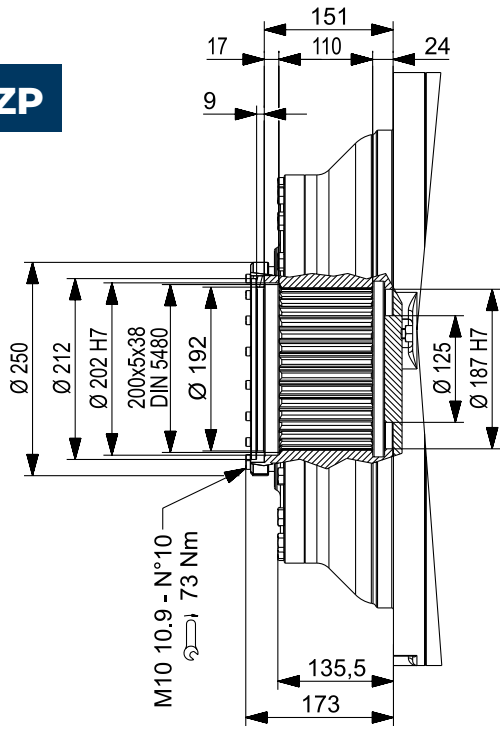

FP

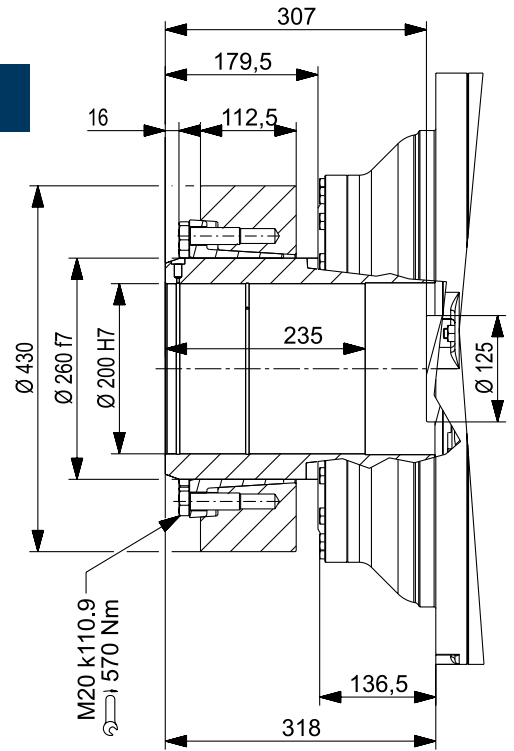

$M_{2\text{max}} = 242000 \text{ Nm}$

3/H 18L2

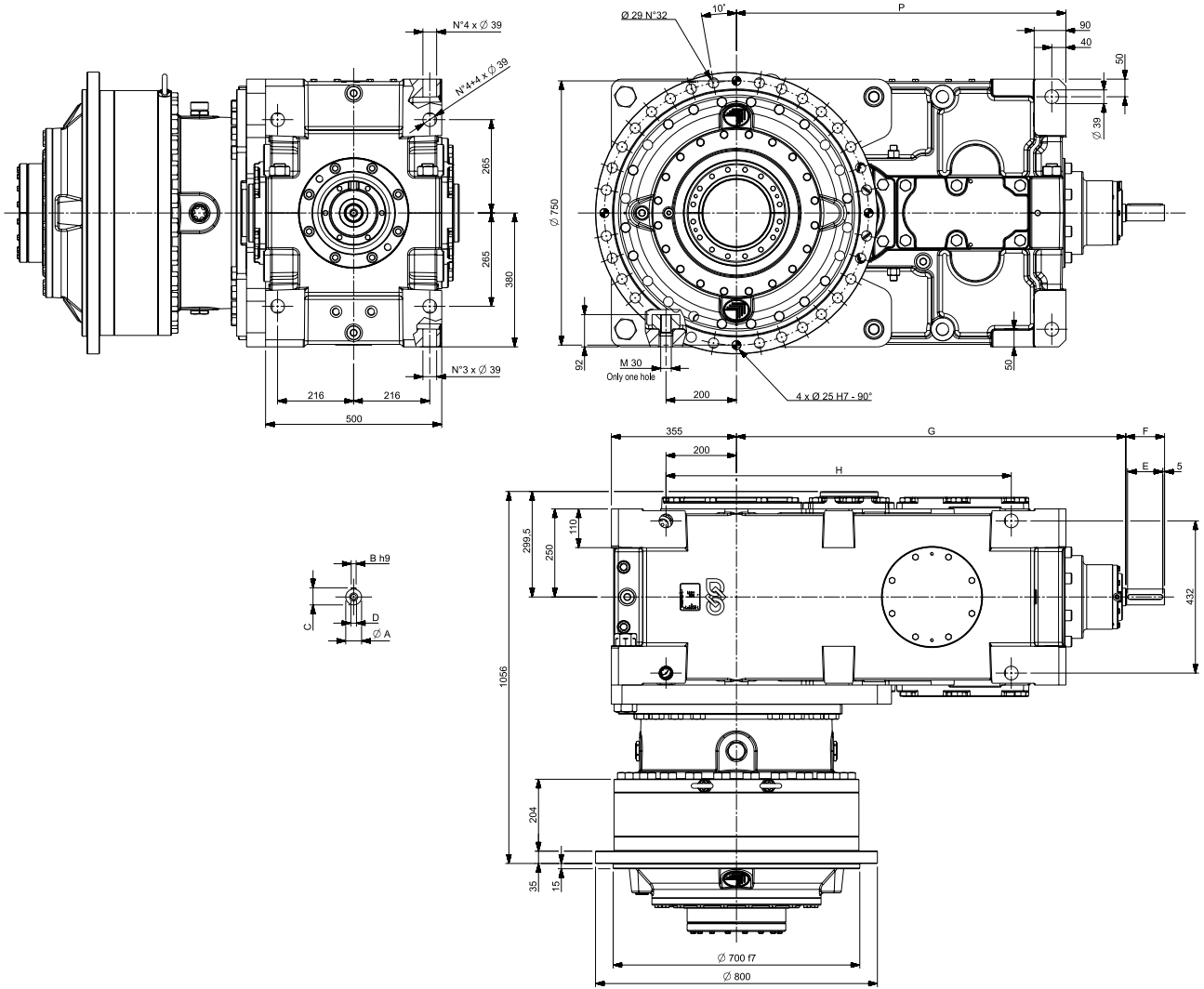

VP	i =	A [mm]	B [mm]	C [mm]	D [mm]	E [mm]	F [mm]	G [mm]	H [mm]	P [mm]	FP [KG]
3/H 18L2	99.4 295.2	70 m6	20	74.5	M20x42	125	140	1040	980	935	2973
3/H 18L2	314.6 964.0	45 k6	14	48.5	M16x36	100	110	1105	980	935	2943

3/H 18L3

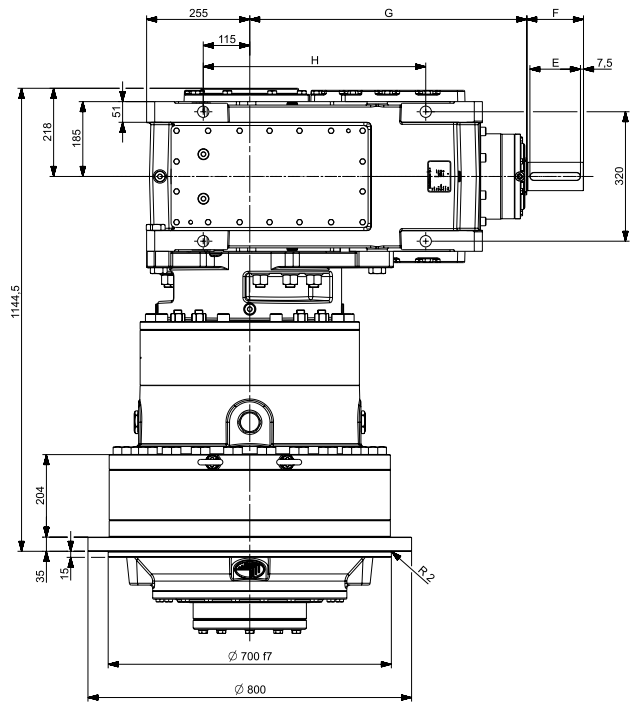
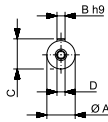
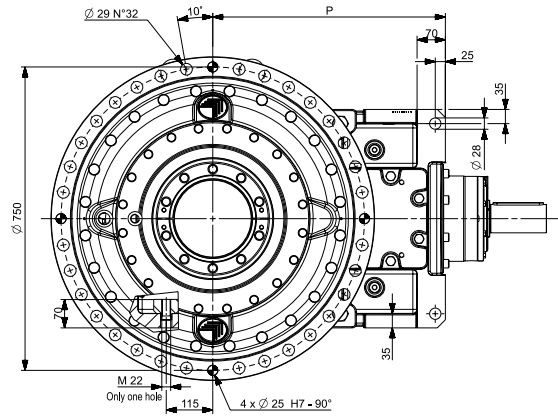
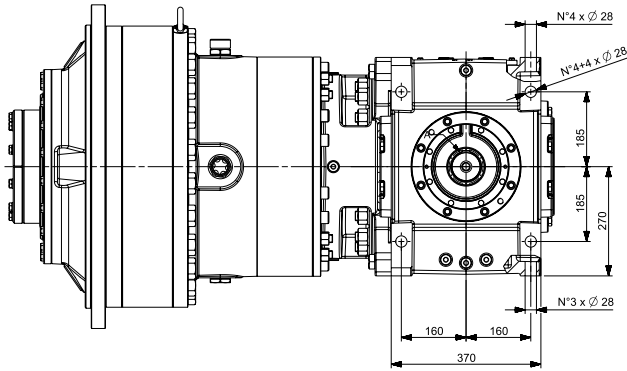

VP	i =	A [mm]	B [mm]	C [mm]	D [mm]	E [mm]	F [mm]	G [mm]	H [mm]	P [mm]	FP [KG]
3/H 18L3	119.7 364.3	70 m6	20	74.5	M20x42	125	140	685	550	575	2155
3/H 18L3	444.2 491.2	55 m6	16	59	M20x42	100	110	800	670	695	2225
3/H 18L3	517.0 1128	45 k6	14	48.5	M16x36	100	110	800	670	695	2225

3/H 18L2 - 18L3

FZP

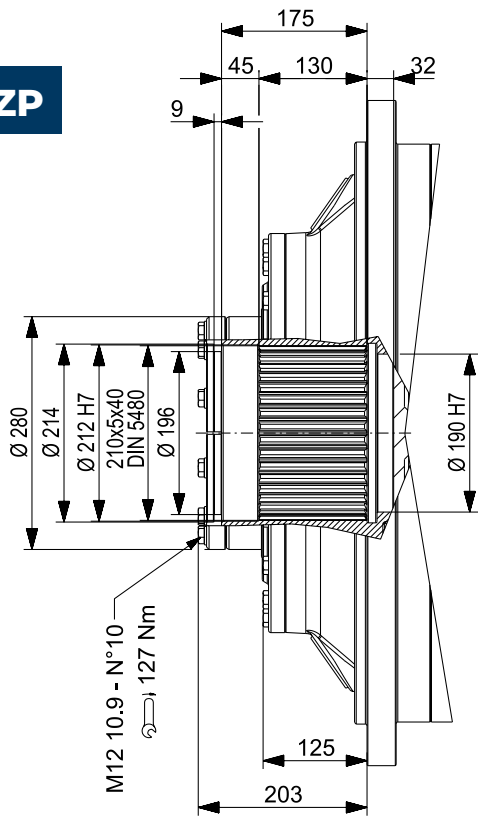

FP

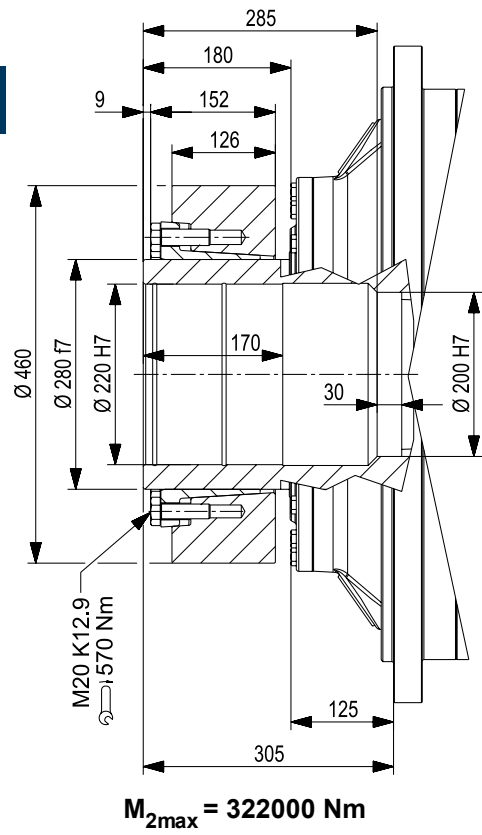

3/H 19L3

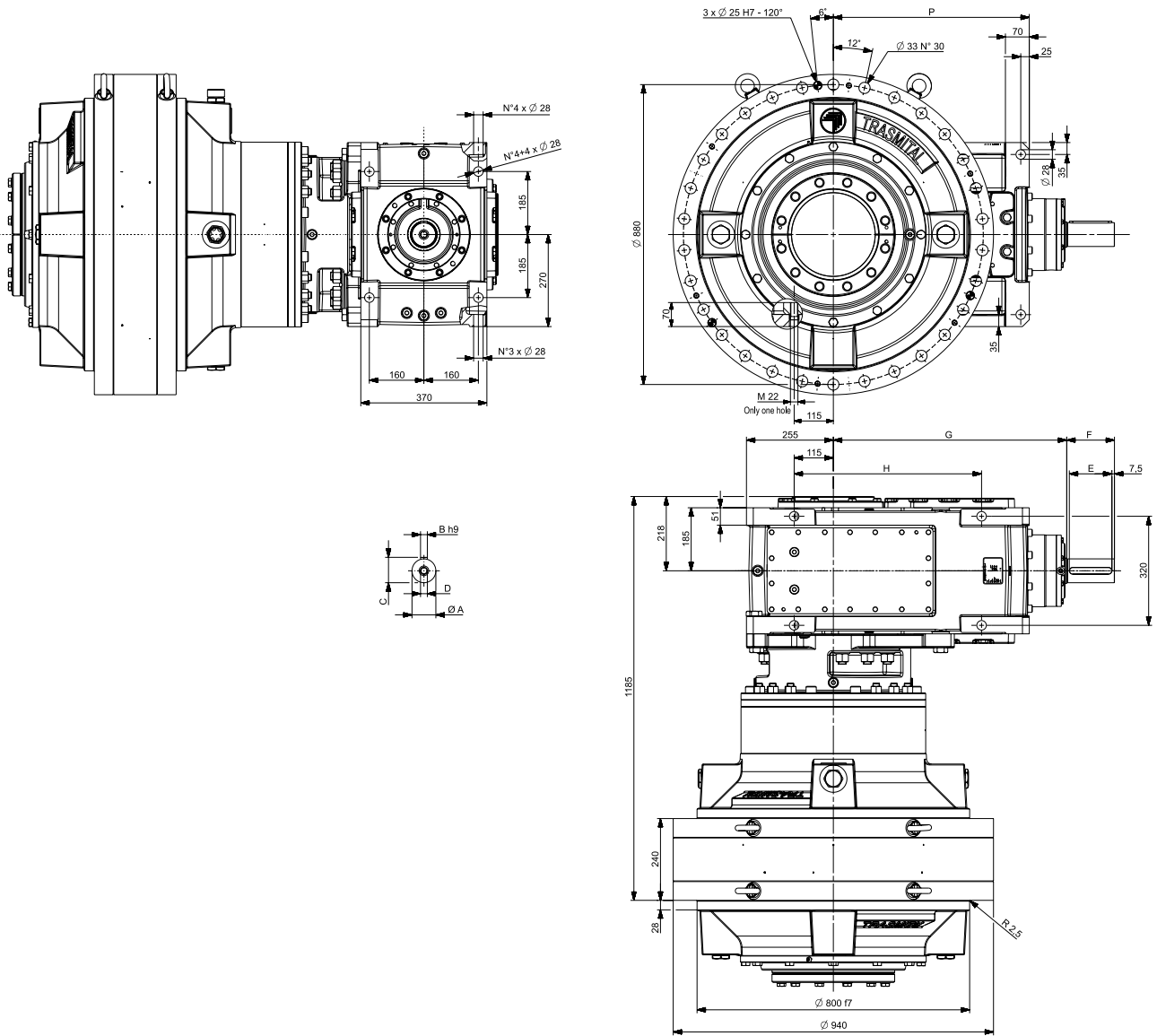

VP	i =	A [mm]	B [mm]	C [mm]	D [mm]	E [mm]	F [mm]	G [mm]	H [mm]	P [mm]	FP [KG]
3/H 19L3	132.5 320.9	70 m6	20	74.5	M20x42	125	140	685	550	575	2765
3/H 19L3	391.2 432.6	55 m6	16	59	M20x42	100	110	800	670	695	2835
3/H 19L3	455.4 993.6	45 k6	14	48.5	M16x36	100	110	800	670	695	2835

3/H 19L2 - 19L3

FZP

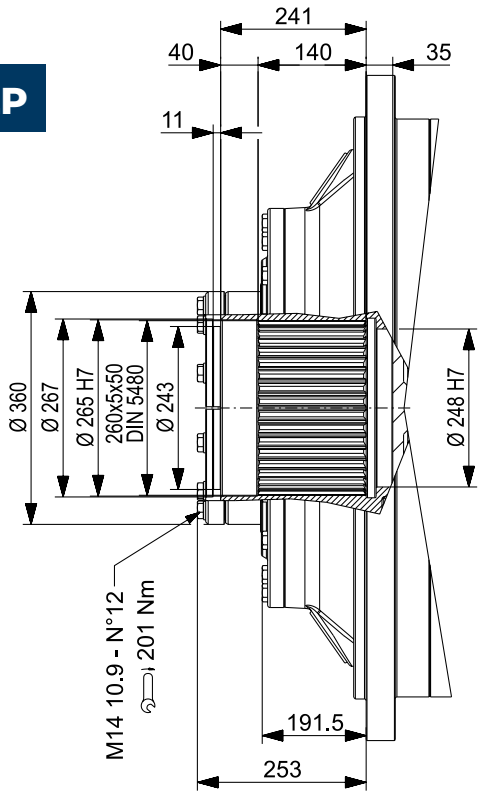

FP

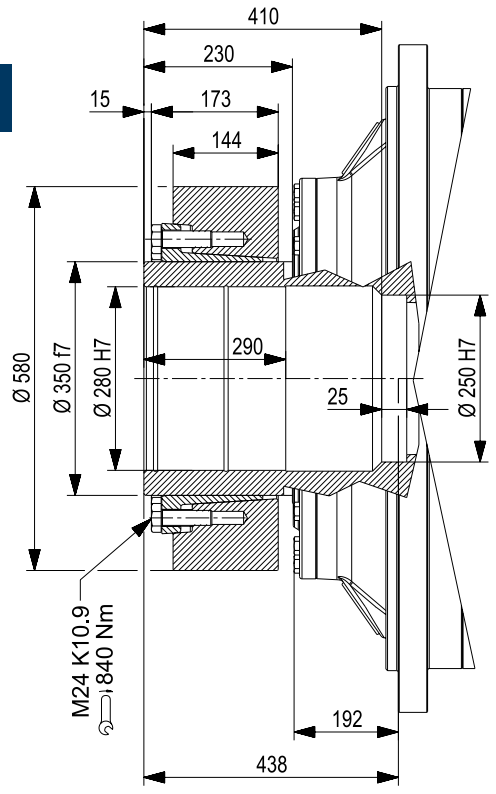

M_{2max} = 480000 Nm

3/H 21L3

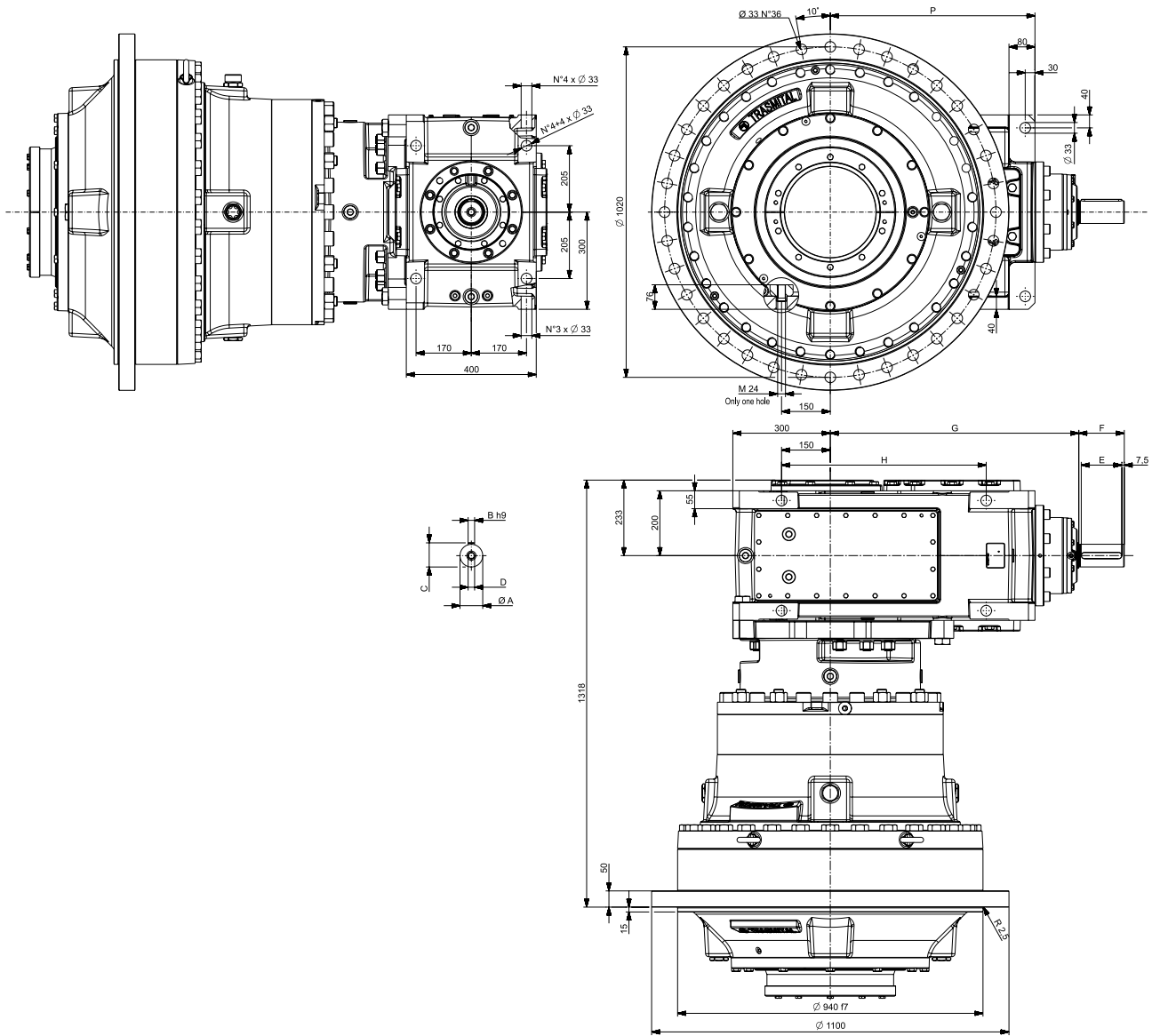

VP	i =	A [mm]	B [mm]	C [mm]	D [mm]	E [mm]	F [mm]	G [mm]	H [mm]	P [mm]	FP [KG]
3/H 21L3	120.1 361.2	70 m6	20	74.5	M20x42	125	140	685	550	575	3860
3/H 21L3	403.1 573.2	55 m6	16	59	M20x42	100	110	855	630	630	3940
3/H 21L3	659.4 960.0	45 k6	14	48.5	M16x36	100	110	855	780	780	3940

3/H 23L3

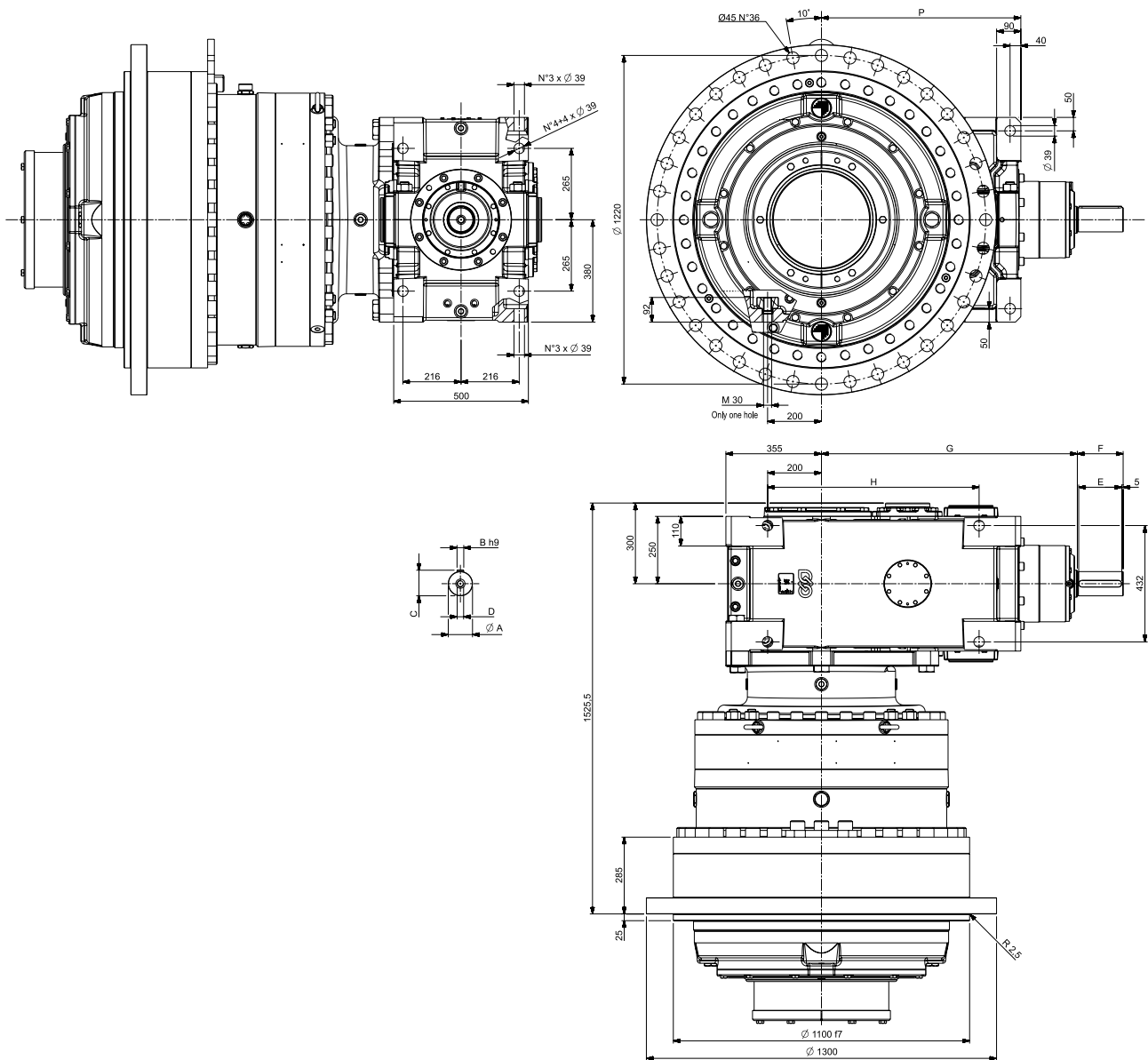

VP	$i =$	A [mm]	B [mm]	C [mm]	D [mm]	E [mm]	F [mm]	G [mm]	H [mm]	P [mm]	FP [KG]
3/H 23L3	121.5 266.6	70 m6	20	74.5	M20x42	125	140	950	785	740	6675
3/H 23L3	297.9 936.9	45 k6	14	48.5	M16x36	100	110	1040	980	935	6835

3/H 23L3

FZP

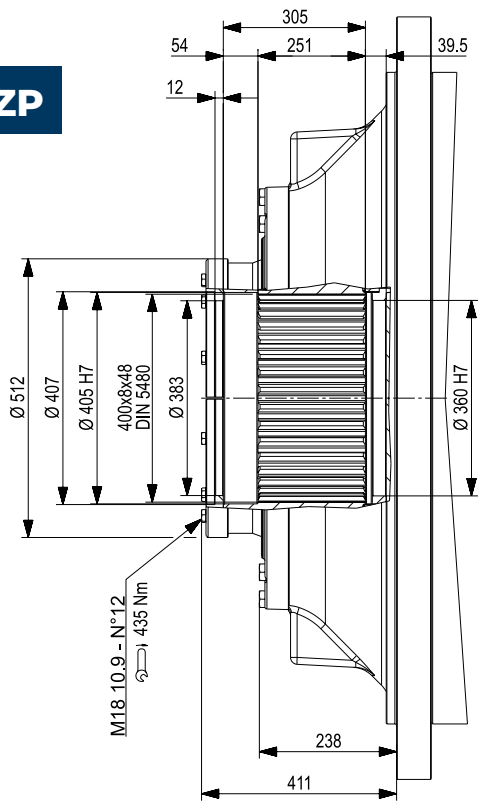

FP

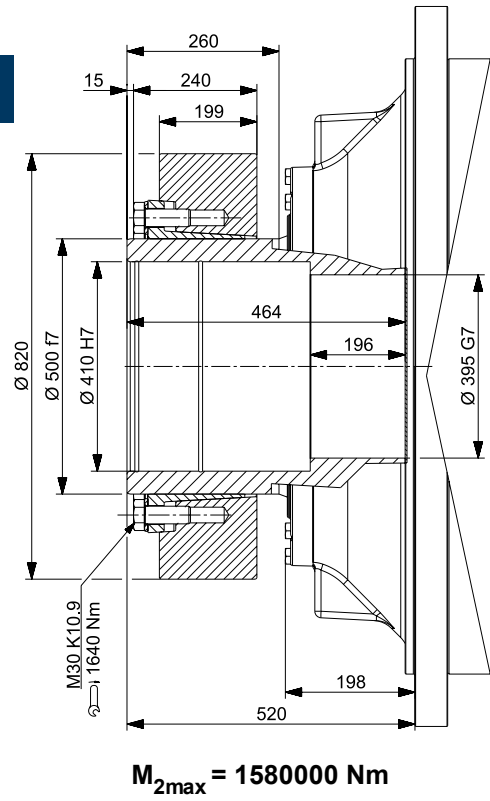

3/H 25L3

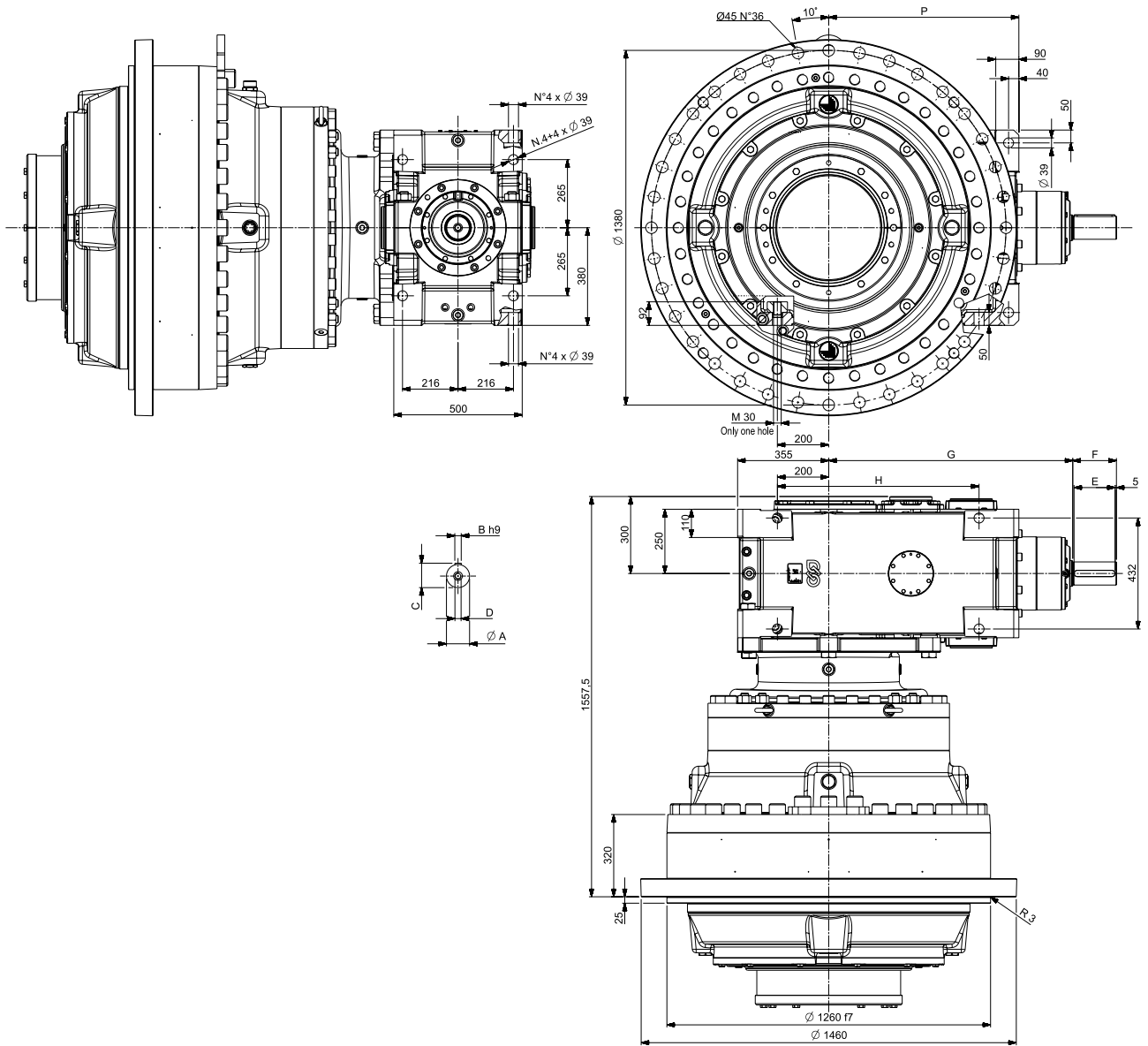

VP	i =	A [mm]	B [mm]	C [mm]	D [mm]	E [mm]	F [mm]	G [mm]	H [mm]	P [mm]	FP [KG]
3/H 25L3	127.7 304.6	70 m6	20	74.5	M20x42	125	140	950	785	740	8140
3/H 25L3	340.5 1071	45 k6	14	48.5	M16x36	100	110	1040	980	935	8300



3/H 25L3

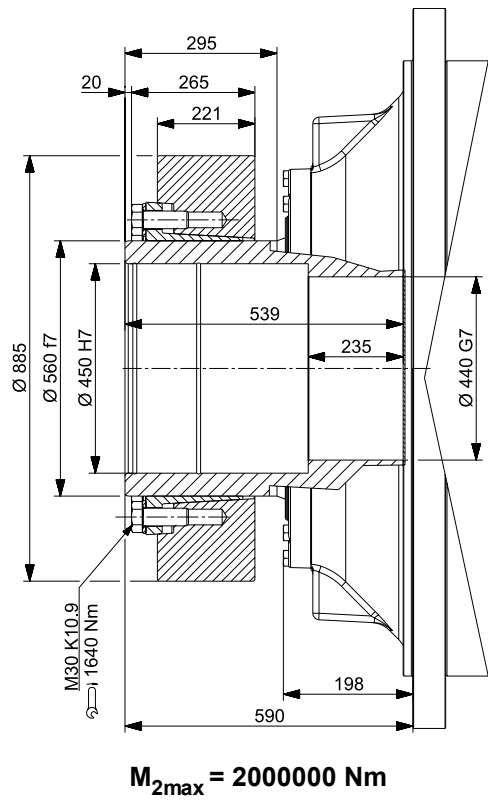
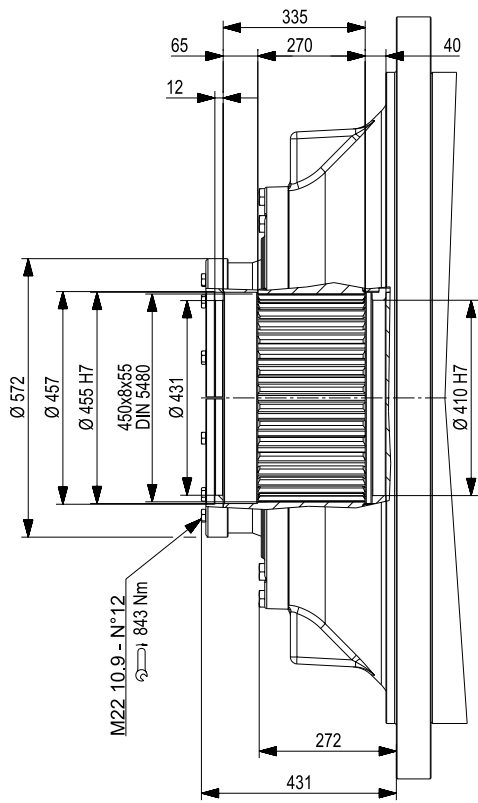

20. MOTOR ADAPTER DIMENSIONS WITH BELL HOUSING AND IEC FLEXIBLE COUPLING [mm]

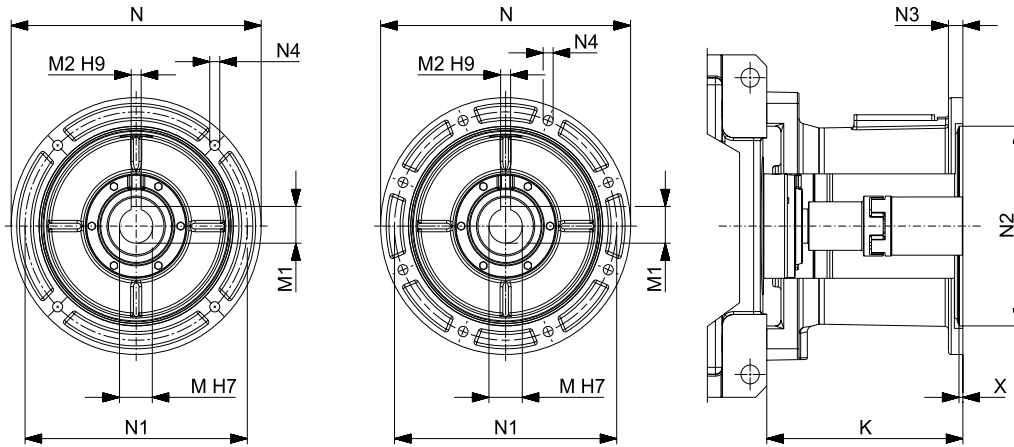

GR	M	M1	M2	N	N1	N2	N3	N4	X	K
112	28	31.3	8	250	215	180	15	14	5	
132	38	41.3	10	300	265	230	-	M12x20	6	
160	42	45.3	12	350	300	250	23	18	6	
180	48	51.8	14	350	300	250	23	18	6	
200	55	59.3	16	400	350	300	-	M16x23	7	
225	60	64.4	18	450	400	350	26	18	7	
250	65	69.4	18	550	500	450	30	18	6	
280	75	79.9	20	550	500	450	30	18	6	
315	80	85.4	22	660	600	550	22	22	10	

Tab. 1/2

21. MOTOR ADAPTER DIMENSIONS WITH BELL HOUSING AND NEMA FLEXIBLE COUPLING [inch]

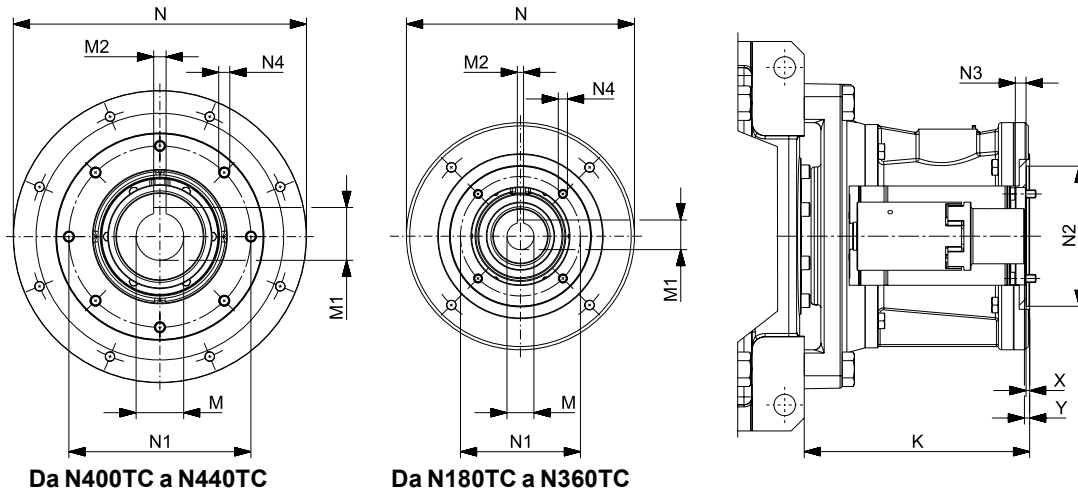

GR	M	M1	M2	N	N1	N2	N3	N4	X	Y	K
N180TC	1.125 +0.0014 +0.0006	1.241	0.25	+0.0014	9.843	7.25	8.5	0.453	0.551	0.217	0.061
N210TC	1.375 +0.0014 +0.0006	1.518	0.312	+0.0014	9.843	7.25	8.5	0.453	0.551	0.217	0.128
N250TC	1.625 +0.0018 +0.0008	1.796	0.375	+0.0014	13.78	7.25	8.5	0.65	0.551	0.217	0.09
N280TC	1.875 +0.0018 +0.0008	2.102	0.5	+0.0017	13.74	9	10.5	0.512	0.551	0.217	0.09
N320TC	2.125 +0.0022 +0.0010	2.35	0.5	+0.0017	17.677	11	12.5	0.669	0.669	0.217	0.079
N360TC	2.375 +0.0022 +0.0010	2.651	0.625	+0.0017	17.677	11	12.5	0.669	0.669	0.217	0.108
N400TC	3.875 +0.0022 +0.0010	3.205	0.75	+0.002	17.677	11	12.5	0.669	0.669	0.217	1.488
N440TC	3.375 +0.0026 +0.0012	3.76	0.875	+0.002	25.984	11	16	0.748	0.709	0.236	1.56

Tab. 1/2

Tab. 1		K [mm] - (G)									
		i =	112	132	160	180	200	225	250	280	315
3/H 11L2			260	280	346	346	371	378	408	408	-
3/H 13L2			260	280	346	346	371	378	408	408	-
3/H 15L2	≤ 300		-	-	-	351	376	383	413	413	449.5
	> 300		-	285	315	315	376	383	-	-	-
3/H 15L3			-	-	346	346	371	378	408	408	-
3/H 16L2	≤ 450		-	-	351	351	376	383	413	413	449.5
	> 450		-	285	315	315	376	383	-	-	-
3/H 16L3			-	-	346	346	371	378	408	408	-
3/H 17L2			-	-	321	321	346	353	383	383	419.5
3/H 17L3			-	-	346	346	371	378	408	408	-
3/H 18L2	≤ 300		-	-	-	-	-	-	415.5	415.5	452
	> 300		-	-	416	416	441	448	478	478	-
3/H 18L3	≤ 400		-	-	-	-	-	-	420.5	457	
	> 400		-	-	351	351	376	383	413	413	449.5
3/H 19L2	≤ 400		-	-	-	-	-	-	415.5	415.5	452
	> 400		-	-	416	416	441	448	478	478	-
3/H 19L3	≤ 350		-	-	-	-	-	-	420.5	457	
	> 350		-	-	-	351	376	383	413	413	449.5
3/H 21L3	≤ 400		-	-	-	-	-	-	-	482	
	> 400		-	-	-	-	353	383	383	419.5	
3/H 23L3			-	-	-	-	-	478	478	590	
3/H 25L3			-	-	-	-	-	478	478	590	

Tab. 2		K [mm] - (NG)								
		i =	N180TC	N210TC	N250TC	N280TC	N320TC	N360TC	N400TC	N440TC
3/H 11L2			11.22	11.22	14.39	14.587	15.925	15.925	16.516	-
3/H 13L2			11.22	11.22	14.39	14.587	15.925	15.925	16.516	-
3/H 15L2			-	11.417	14.587	14.783	16.122	16.122	16.713	-
3/H 15L3			-	-	14.39	14.587	15.925	15.925	16.516	-
3/H 16L2			-	-	14.587	14.783	16.122	16.122	16.713	-
3/H 16L3			-	-	14.39	14.587	15.925	15.925	16.516	-
3/H 17L2			-	-	13.405	13.602	14.941	14.941	15.531	17.992
3/H 17L3			-	-	14.39	14.587	15.925	15.925	16.516	-
3/H 18L2	≤ 300		-	-	-	-	-	16.220	16.811	19.272
	> 300		-	-	-	17.343	18.681	18.681	19.272	-
3/H 18L3	≤ 400		-	-	-	-	-	17.008	-	
	> 400		-	-	14.587	14.783	16.122	16.122	16.713	-
3/H 19L2	≤ 400		-	-	-	-	-	16.220	16.811	19.272
	> 400		-	-	-	17.343	18.681	18.681	19.272	-
3/H 19L3	≤ 350		-	-	-	-	-	17.008	-	
	> 350		-	-	-	14.783	16.122	16.122	16.713	-
3/H 21L3	≤ 400		-	-	-	-	-	-	-	20.453
	> 400		-	-	-	-	14.941	14.941	15.531	17.992
3/H 23L3			-	-	-	-	-	16.220	16.811	19.272
3/H 25L3			-	-	-	-	-	-	-	24.705
3/H 25L3			-	-	-	-	-	16.220	16.811	19.272

The motor adapter dimensions indicated in the table refer to the gear unit geometry. To see the feasible ratios per motor size refer to paragraph 15 on page 20



22. MOTOR MAXIMUM STATIC LOAD VALUES

When fitting motors supplied by a manufacturer other than Bonfiglioli, check that the static bending moment obtained from the motor weight on the gear unit mounting flange is lower than the admissible value given in the table below.



If the motor weight is too high or external movements to which the gearmotor is subjected (e.g. oscillations, rotations) cause the permissible static bending moment value to exceed the value in the table, contact Bonfiglioli's Technical Service.

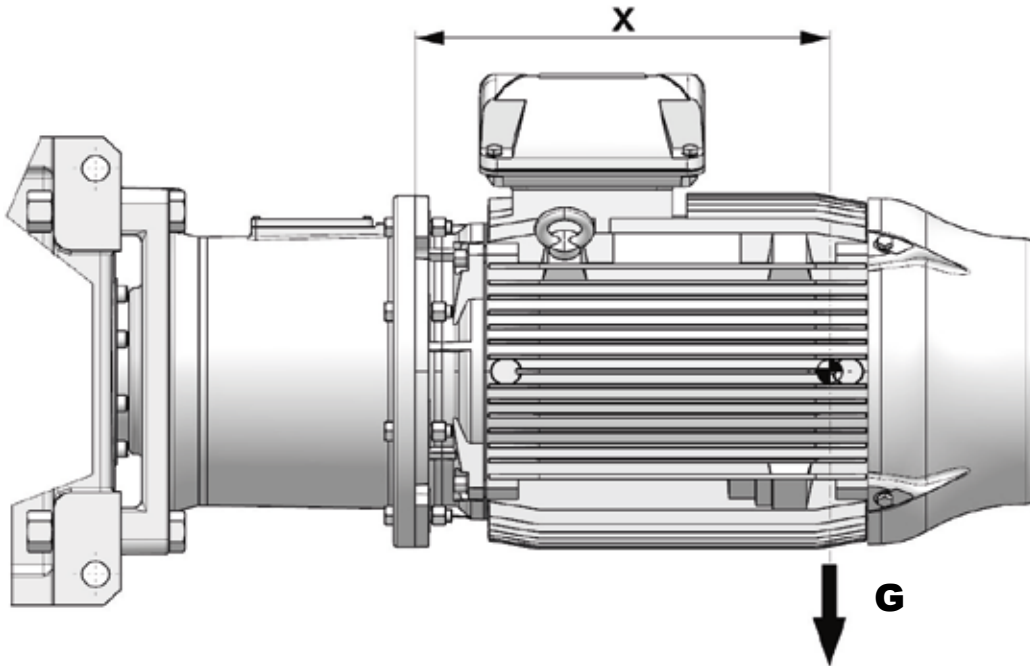

X = Distance in metres [m] of the motor centre of gravity from the motor flange plane, in case of dimension not available use 2/3 of the motor length

G = Motor weight multiplied by 9.81 [N].

Size IEC	Size NEMA	Weight [kg]	Mfs (G*X) [Nm]
100/112	N180TC	60	190
132	N210TC	90	340
160/180	N250TC	220	1100
	N280TC		
200	N320TC	350	1900
225	N360TC	450	2600
250	N400TC	550	3200
280	N440TC	850	6250
315		1400	13100

23. CUSTOMER SHAFT

FZP

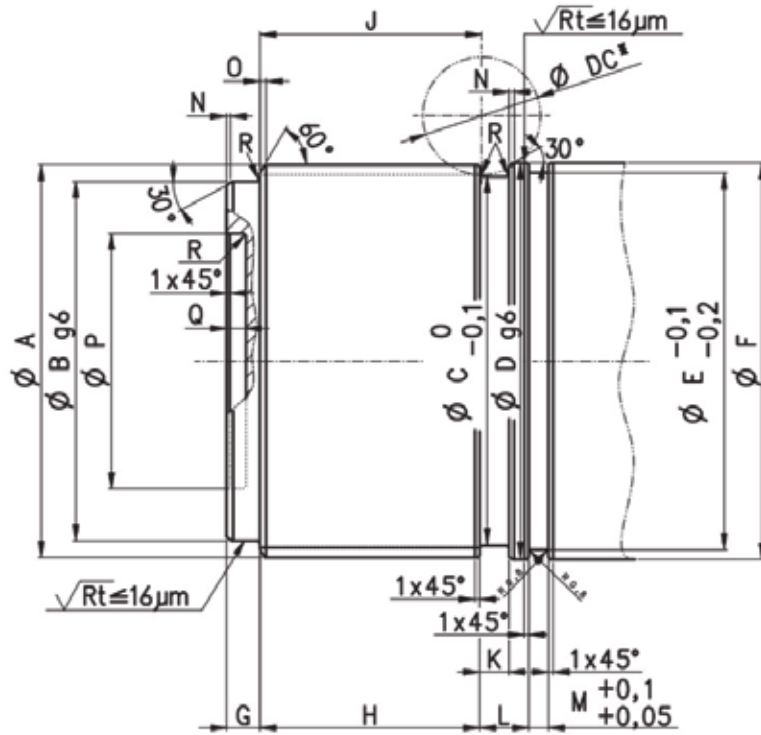

	A Spline DIN 5480 [mm]	B Ø H7 - g6 [mm]	C Groove diameter [mm]	Shaft material	D [mm]	E [mm]	F [mm]	G [mm]	H [mm]	K [mm]	J [mm]	L [mm]	M [mm]	N [mm]	O [mm]	P [mm]	Q [mm]	R [mm]	DC*
3/H 11L2	120x3x38	108	112	Recommended material: Steel with breaking load $\sigma_R \geq 900$ MPa	124	112	124	19	69	9	70	18.5	6	1	1.6	-	-	1.6	60
3/H 13L2	140x5x26	110	132		142	132	142	26	83	189	84	30	6	1	2	-	-	3	60
3/H 15L2	150x5x28	136	136		152	136	152	16	103	8	104	20	8	1	2	-	-	1.6	60
3/H 15L3	150x5x28	136	136		152	136	152	16	103	8	104	20	8	1	2	-	-	1.6	60
3/H 16L2	170x5x32	150	154		172	154	172	30	113	20	114	45	9	1	3	-	-	3	60
3/H 16L3	170x5x32	150	154		172	154	172	30	113	20	114	45	9	1	3	-	-	3	60
3/H 17L2	200x5x38	187	186		202	192	202	16	100	19	101	33	9	1	3.5	130	10	1.6	60
3/H 17L3	200x5x38	187	186		202	192	202	16	100	19	101	33	9	1	3.5	130	10	1.6	60
3/H 18L2	210x5x40	190	194		212	194	212	27	133	20	134	45	9	2	3	-	-	3	60
3/H 18L3	210x5x40	190	194		212	194	212	27	133	20	134	45	9	2	3	-	-	3	60
3/H 19L2	260x5x50	248	243		265	243	265	29	144	20	145	40	11	2	3	-	-	3	60
3/H 19L3	260x5x50	248	243		265	243	265	29	144	20	145	40	11	2	3	-	-	3	60
3/H 21L3	300x8x36	282	281		305	281	305	25	158	25	159	50	12	2	3	-	-	3	70
3/H 23L3	400x8x48	360	381		405	381	405	35	254	26	256	53.5	12	2	4	-	-	5	70
3/H 25L3	450x8x55	410	431		455	431	455	34	272	24	274	66	12	2	4	-	-	5	70



24. CUSTOMER SHAFT

FP

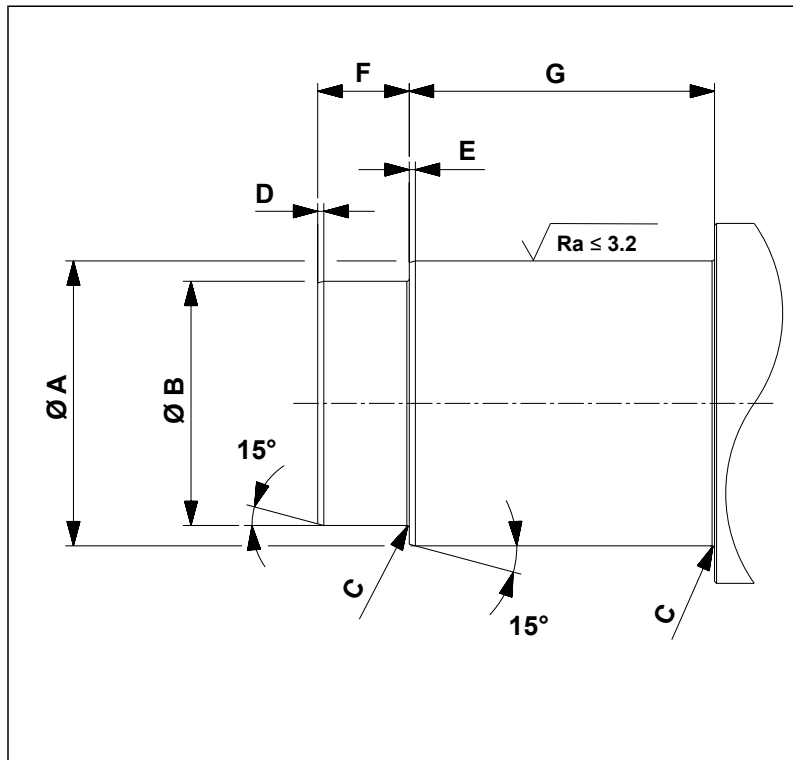

	A H7 - g6 [mm]	B H7 - g6 [mm]	C [mm]	D [mm]	E [mm]	F [mm]	G [mm]	Shaft ma- terial
3/H 11L2	135	-	1.6	-	3	-	150	Recommended material: Steel with breaking load $\sigma_R \geq 700$ MPa
3/H 13L2	140	130	2	3	3	45	150	
3/H 15L2	180	160	1.6	3	3	50	200	
3/H 15L3	180	160	1.6	3	3	50	200	
3/H 16L2	180	165	1.6	3	3	90	180	
3/H 16L3	180	165	1.6	3	3	90	180	
3/H 17L2	200	-	1.6	-	3	-	250	
3/H 17L3	200	-	1.6	-	3	-	250	
3/H 18L2	220	200	2	3	3	130	180	
3/H 18L3	220	200	2	3	3	130	180	
3/H 19L2	280	-	2	-	3	-	300	
3/H 19L3	280	-	2	-	3	-	300	
3/H 21L3	320	-	2	-	3	-	300	
3/H 23L3	410	-	2	-	3	-	250	
3/H 25L3	450	-	2	-	3	-	300	

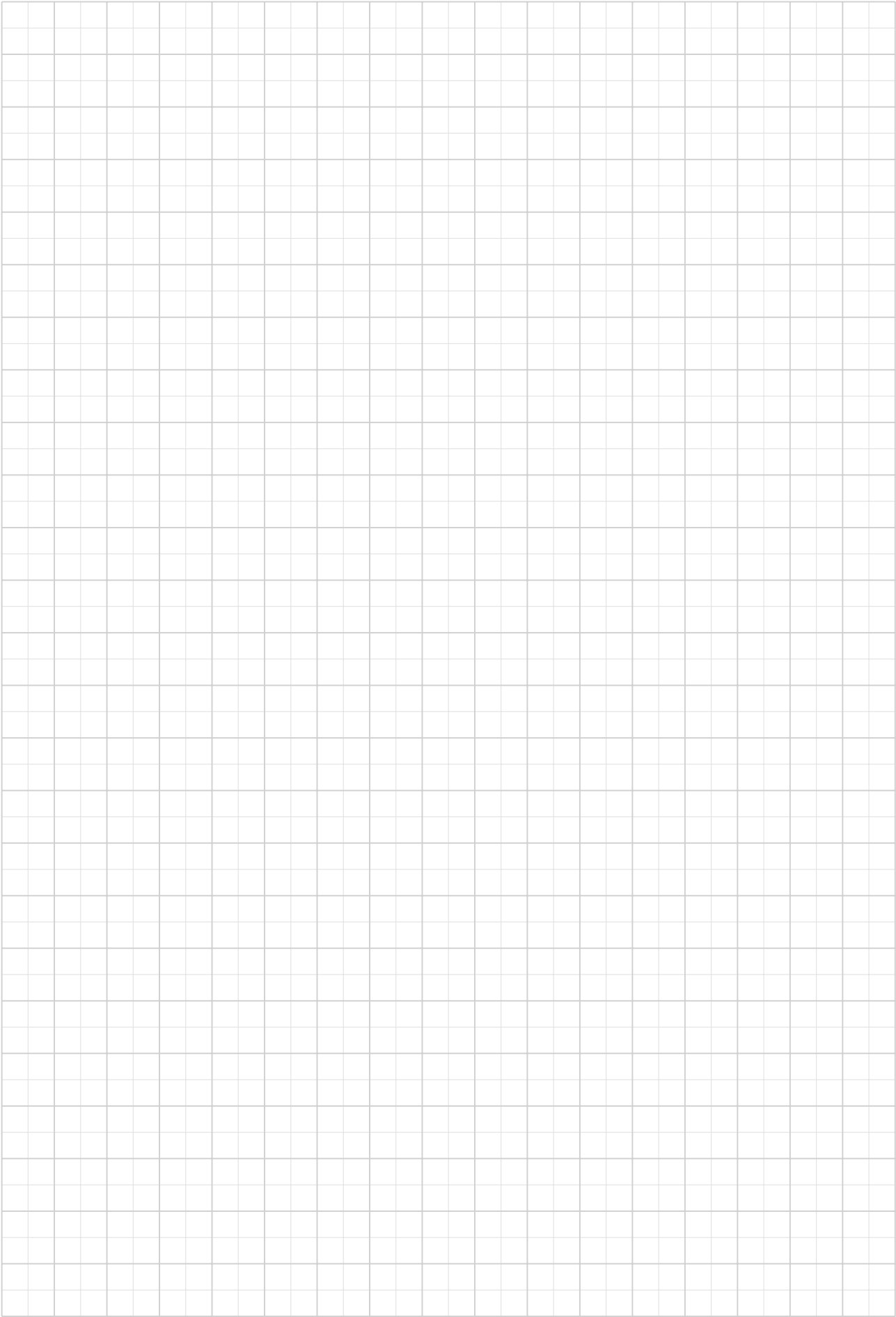

Our worldwide presence

Thanks to an international network of closely interconnected commercial and production sites, we can guarantee the same high standards of Bonfiglioli quality anywhere at any given time. We know that our direct presence in local markets is the key to long-lasting success, so our family includes 17 production sites, 23 commercial sites and more than 550 distributors around the world.

Our organization is always close by, offering complete and efficient solutions and supporting our customers with dedicated services, co-engineering and after-sales assistance.

17  PRODUCTION SITES

23  COMMERCIAL SITES

80  COUNTRIES

550  DISTRIBUTORS

~5,000  PEOPLE

Bonfiglioli global locations

AUSTRALIA

Bonfiglioli Transmission (Aust.) Pty Ltd
Plumpton NSW



BRAZIL

Bonfiglioli Redutores do Brasil Ltda
São Bernardo do Campo - São Paulo



CHINA

Bonfiglioli Drives (Shanghai) Co. Ltd.
Shanghai



Selcom Electronics (Shanghai) Co., Ltd
Shanghai



Shanghai



FRANCE

Bonfiglioli Transmission S.A.S.
Marly la Ville



GERMANY

Bonfiglioli Deutschland GmbH
Neuss



Bonfiglioli Deutschland GmbH
Krefeld



O&K Antriebstechnik GmbH
Hattingen



INDIA

Bonfiglioli Transmission Ltd.
Mobility & Wind Industries

Thirumudivakkam
Kancheepuram - Tamil Nadu



Industry & Automation Solutions

Mannur Village, Sriperumbudur Taluk
Kancheepuram - Tamil Nadu



Industry & Automation Solutions

Pune - Maharashtra



ITALY

Bonfiglioli Riduttori S.p.A.

Industry & Automation Solutions
Calderara di Reno (BO)



Industry & Automation Solutions

Carpiano



Mobility & Wind Industries

Forlì



Industry & Automation Solutions

Rovereto



Selcom Group S.p.A.

Castel Maggiore (BO)



Castel Maggiore (BO)



Cadriano (BO)



NEW ZEALAND

Bonfiglioli Transmission (Aust.) Pty Ltd
Auckland - Ellerslie



SINGAPORE

Bonfiglioli South East Asia Pte Ltd
Singapore



SLOVAKIA

Bonfiglioli Slovakia s.r.o.
Považská Bystrica



SOUTH AFRICA

Bonfiglioli South Africa Pty Ltd.
Johannesburg



SPAIN

Tecnotrans Bonfiglioli S.A
Castellbisbal - Barcelona



TURKEY

Bonfiglioli Türkiye Jsc
Çiğli - Izmir



UNITED KINGDOM

Bonfiglioli UK Ltd.
Warrington - Cheshire
Tel. +44 1925 852667



USA

Bonfiglioli USA Inc.
Hebron - Kentucky



VIETNAM

Bonfiglioli Vietnam Co. Ltd.
Ben Cat city, Binh Duong province





We have a relentless commitment to excellence, innovation & sustainability. Our team creates, distributes and services world-class power transmission & drive solutions to keep the world in motion.

HEADQUARTERS

Bonfiglioli S.p.A.

Via Cav. Clementino Bonfiglioli, 1
40012 Calderara di Reno - Bologna (Italy)
Tel. +39 051 6473111

