

BX-BE-BN-MX-ME-M- BXN-MXN-MNN SERIES

Installation, Operation and Maintenance Manual

 **Bonfiglioli**

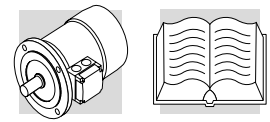

OWNER'S MANUAL FOR ELECTRIC MOTORS SERIES BX, BE, BN, MX, ME, M BXN, MXN, MNN



Description

1	Field of application	2
2	General safety info	2
3	Installation	2
4	Wiring	6
5	Start-up	13
6	Maintenance	13
7	Disassembly, recycling or disposal	16
8	Spare parts	18



Read carefully



Electrical hazard

Revisions

Refer to page 38 for the catalogue revision index.

Visit www.bonfiglioli.com to search for catalogues with up-to-date revisions.

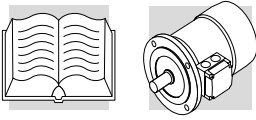

1 FIELD OF APPLICATION

The following instructions apply to the three-phase asynchronous electric motors manufactured by BONFIGLIOLI RIDUTTORI S.p.A., series:

- **BXN, BX, BE, BN**
- **MXN, MX, ME, M, MNN**

in their standard version, with or without brake.

Special versions as described in the catalogues and/or in offers, or special applications (for example, power supply from inverter) will require additional information.

2 GENERAL SAFETY INFORMATION

The electric motors described in the following instructions are designed to be used in industrial installations and must be operated by qualified personnel only.



During operation, motors have live or moving parts. Therefore, removal of electrical or mechanical guards, improper use, or inadequate maintenance may cause serious damage to persons or property.



Installation and maintenance on motors must be performed only by qualified personnel who have thorough knowledge of the instructions and technical data for the product and who have been authorised to perform such operations by the safety supervisor.



Since the electric motor does not have a defined function for the final user and is going to be physically coupled to another machine, it is the responsibility of the installer to guarantee that all provisions for its safe operation have been taken.

3 INSTALLATION

3.1 Identification

Gearmotors and motors have a nameplate carrying their identification data.

In the case of serial number composed of 17 digits, the year of production is identified by digits 3-4.
In the case of serial number composed of 13 digits, the year of production is identified by digits 5-6.
See the following examples:

0	1	1	9	0	0	0	7	1	3	2	4	5	9	0	0	1
1	2	3	4	5	6	7	8	9	10	11	12	13	14	15	16	17
X	X	X	X	X	X	X	X	X	X	X	X	X	X	X	X	X
Month		Year														

E	V	O	1	9	0	0	0	0	0	0	1	
1	2	3	4	5	6	7	8	9	10	11	12	13
X	X	X	X	X	X	X	X	X	X	X	X	X
Year												

Table shows the plate used for all motor configurations.

On standard voltage electric motors with an FD brake, the nameplate only gives electrical data for the frequency identified by the motor designation.

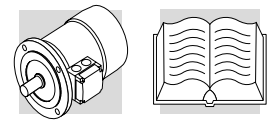

On non-standard voltage electric motors with a brake, the nameplate only gives electrical data for the frequency identified by the motor designation.

On motors with the CUS option, the nameplate only gives electrical data for the frequency identified by the motor designation.

Some example of precompiled nameplates

BX, BE, BN, MX, ME, M

IEC EN 60034			
3~Mot BN 90LA 4 FD		Cod. 8D440xxxxx	
No xxxxxxxx - xxxxxxxx	S 2-20min IM B14 19,6 kg		
kW 1,5/50Hz-1,8/60Hz		CL F IP 55 Amb -40/+60°C	
Hz	V	A	min ⁻¹ cos φ
50 ○	230/400 Δ/Y	6.08/3.51	1375 ○ 0.77
60	265/460 Δ/Y	6.25/3.61	1730 ○ 0.74
50Hz	380-415 VY	6.25-3.61A	IE1 82.5%
60Hz	440-480 VY	6.25-3.61A	IE1 82.5%
FAN UNIT 3~230/400V Δ/Y 50Hz			
H1 1~230V ± 10% 10W			
VB ~230V ± 10% MB=26Nm NB		Made in xxxxx - xxxxx	

ENERGY c			
3~Mot BX 90LA 4 FD		Cod. xxxxxxxxx	
No xxxxxxxx - xxxxxxxx	S 1 IM B14 22,6 kg		
kW 1,5 HP 2		CL F IP 55 Amb 40 °C	
Hz	V ± 10%	A	min ⁻¹ cos φ
60 ●	265/460 Δ/Y	6.08/3.51	1770 ● 0.77
60Hz - IE3 91,7(100%) - 91,1(75%) - 89,5(50%)			
TEFC - kVA Code K			
H1 1~230V ± 10% 10W			
VB ~265V ± 10% MB=26Nm NB		Made in xxxxx - xxxxx	

BXN, MXN, MNN

3~Mot BXN 90L 4 FD TEFC IMB14 IP55 22,6 kg			
Cod. xxxxxxxxx	No xxxxxxxx - xxxxxxxx		
kW 1,5 HP 2 Amb 40 °C CLF S1			
Hz	V	A	min ⁻¹ cos φ
50	115/200 ΔΔ/Y	11.9/6.88	1441 0.75
50	230/400 Δ/Y	5.96/3.44	1441 0.75
60 ○	132/230 ΔΔ/Y	10.1/5.84	1750 ○ 0.74
60	265/460 Δ/Y	5.6/2.92	1750 0.74
50Hz IE3 - 85.3 (100%) 84.3 (75%) 81.7 (50%) - KWA code J			
60Hz IE3 - 86.5 (100%) 86.5 (75%) 83.4 (50%) - KWA code L			
H1 1~230V ± 10% 10W			
VB = 230V MB = 26Nm NB SA			
	IEC EN 60034		
		CC320B	
Bonfiglioli Riduttori S.p.A. Made in Italy			

3.2 Reception

Upon receipt of the motor, check that it was not damaged during transportation; if damage is noted, inform the carrier immediately. In addition, check that the characteristics stated on the plate conform to those ordered and confirmed by BONFIGLIOLI RIDUTTORI S.p.A.

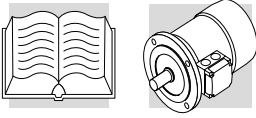

3.3 Transport and handling

Cartons containing more than one motor are usually attached to wooden boards to facilitate handling by forklifts or transpallets.

Motors may be handled individually by lifting them with belts or chains (if required due to weight).

Motors of frame sizes BXN 100 / MXN30, BX 100 / MX3, BE 100 / ME3 and BN 100 / M3 and larger, are provided with an eyebolt / lifting point for lifting purposes.



The eyebolts / lifting points are suitable for lifting the motor only.

Make sure that the motor rests in a stable manner and will not roll (in the case of flanged motors).

3.4 Storage

Observe the following instructions to ensure correct storage of products:

- a) Do not store outdoors, in areas exposed to weather or with excessive humidity.
- b) Always place boards in wood or other material between floor and products, to avoid direct contact with the floor.
- c) For storage periods exceeding 60 days, all coupling surfaces such as flanges and shafts must be protected with a suitable anti-oxidation product (Mobilarma 248 or equivalent).
- d) For storage periods exceeding 6 months, it is a good rule to turn the rotor every 1-2 months and to take adequate measures against corrosion and humidity.

3.5 Motor installation



Check that mains assembly and service conditions comply with the information on the plate and described in the technical documentation.

The following instructions must be observed when installing the motor:

Prior to installing the motor remove from the shaft the plastic guards that are supplied for transportation purposes.

These must be disposed of according to the rules applicable in the Country where the installation takes place.

If applicable, remove oxidation preventative coating of shaft by means of a suitable solvent, which afterwards must be disposed of according to the regulations applying locally.



Do not let the solvent be in touch with oilseal lips.

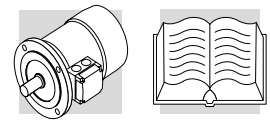

Make sure that the motor is well-ventilated, that there is nothing to obstruct the free circulation of air, and that no situation will arise that could block the regular heat dissipation.

The installation must also allow the performance of ordinary maintenance on the motor and, if supplied, of the brake.



Avoid hitting on the motor shaft: bearings may be damaged.

In outdoor installations, protect the motor from direct sun radiation and, if possible, from inclement weather.

Prior to fitting flanged motors onto gear units make sure that the key is retained safely into the key seat. Coat thoroughly motor shaft with a suitable anti-seize product (Loctite 767 or equivalent) to prevent fretting corrosion and facilitate removal of motor at a later time.

Every 6-12 months it may be recommended to remove the motor from the gear head, clean the shaft area and re-apply the anti-seize product.

In order to avoid vibration once in operation, make sure the motor is secured tightly to mating gearbox flange. Should the motor need to be painted, screen name plate as well as vented plug (if applicable) and machined parts on beforehand.

After the installation of a brake motor is complete, unscrew and remove the lever that operates the manual brake release, thus preventing any accidental operation of the same.

3.6 Balancing

The rotor shaft is dynamically balanced with half key fitted. Assembly of external transmission unit must be performed with adequate instruments after suitable balancing, avoiding knocks which could damage the bearings.

Be especially careful not to operate the motor without having properly secured the key not being used (motors with two shaft ends).



Adopt adequate measures to avoid accidental contact with exposed live or moving parts.



Avoid contact with the motor case, since the temperature under normal operating conditions may exceed 50 °C.

3.7 Insulation test

Before start-up, or after long storage (or idle) periods, check insulation resistance to mass with Megger at 500V DC.

The value measured at 25 °C for new windings in good condition should exceed 10 MΩ. If this value is not reached, oven drying will be required to eliminate excess humidity.

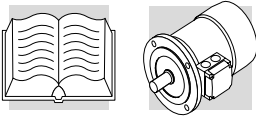

4 WIRING

4.1 Norms applicable to all motors

Use cables with suitable section for the rated current and for installation conditions, avoiding excessive heating and/or voltage drops. Connection at the terminal board must be performed according to the diagrams shown in chart below or according to the instructions supplied in the terminal box, using the appropriate plates, nuts and washers. Earth according to current norms before connecting to the mains.

In addition to the main terminals, the conduit box may contain thermal protection, anti-condensation heaters, and brake connections.

Wire any device according to the diagrams contained in the conduit box.

Legacy motors (BN-M, BE-ME, BX-MX)

Single-speed

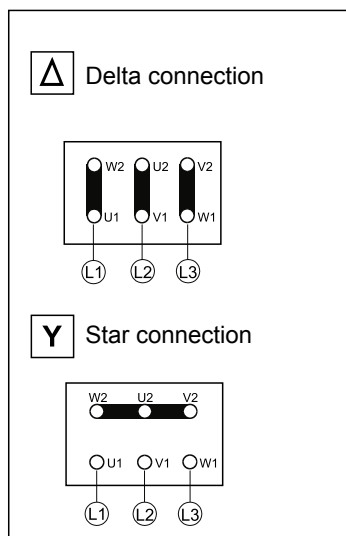

Two-speed

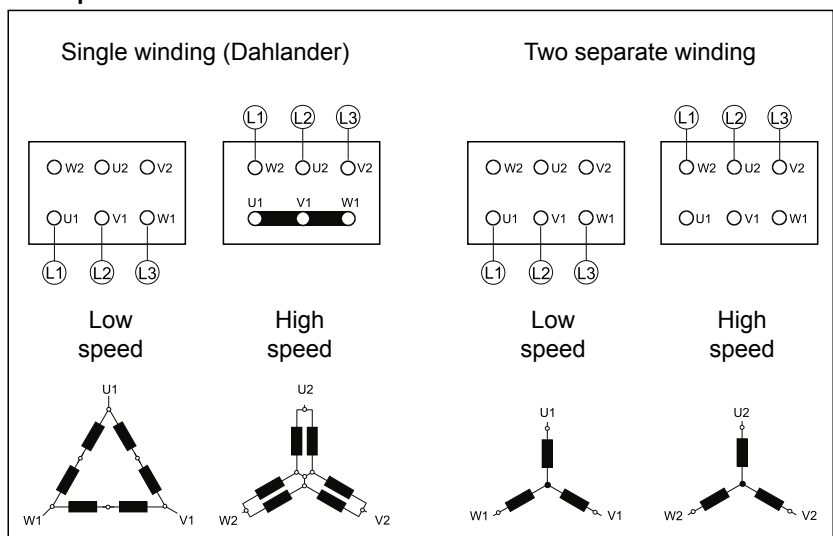

EVOX motors (MNN, BXN-MXN)

Single-speed

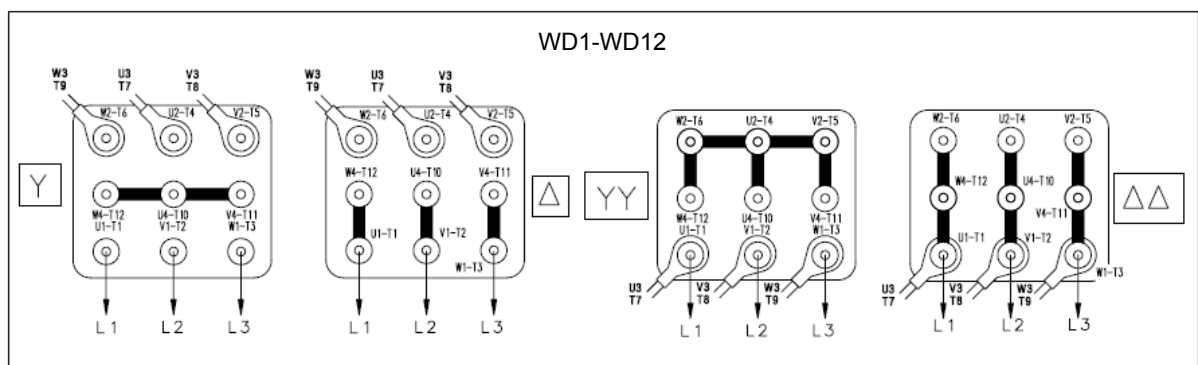

During rest time voltage may still apply to terminals of the heaters and/or the brake. When installing, repairing or maintaining the motor double check that all connections to the mains have been cut.



Furthermore, always prevent uncontrolled restarting of the motor as this may be extremely hazardous for the operator.

At the end of the wiring operations, place the gasket on its site and close the cover. Carefully tighten the cable gland and close all the openings that are not used.

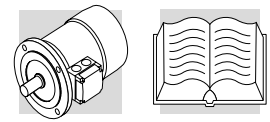

4.2 Anti-condensate heaters



Power to the anti-condensate heaters must be supplied separately and it must always be disconnected while the motor is operating.

4.3 Ventilation

Motors are cooled through outer air blow (IC 411 according to CEI EN 60034-6) and are equipped with a plastic radial fan, which operates in both directions.



Ensure that fan cover is installed at a suitable distance from the closest wall so to allow air circulation and servicing of motor and brake, if fitted.

On request, all BX/MX, BE/ME motors and BN/M motors, starting from BN 71 or M1 size, can be supplied with independently power-supplied forced ventilation system.





Motor is cooled by an axial fan with independent power supply and fitted on the fan cover (IC 416 cooling system).

Brake motors with rear shaft projection (PS option) are excluded.

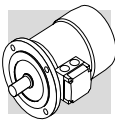
4.4 Ratings of separate supply fan units

U1					
Fan wiring terminals are housed in a separate terminal box					
		V a.c. ±10%	Hz	P [W]	I [A]
BN 71 - BE 71	ME1 - M1	1~230	50 / 60	22	0.12
BX 80 - BE 80 BN 80	MX2 - ME2 M2			22	0.12
BX 90 - BE 90 BN 90	-			40	0.30
BX 100 - BE 100 BN 100	MX3 - ME3 M3			50	0.25
BX 112 - BE 112 BN 112	-			50	0.26 / 0.15
BX 132 - BE 132 BN 132 ... BN 160MR	MX4 - ME4 M4L	3~230Δ / 400Y	50	110	0.38 / 0.22
BX 160 - BE 160 BN 160M ... BN 180M	MX5 - ME5 M5			180	1.23 / 0.71
BX 180 - BE 180 BN 180L ... BN 2000L	-			250	1.39 / 0.80



U2					
Fan terminals are wired in the motor terminal box					
		V a.c. \pm 10%	Hz	P [W]	I [A]
BN 71	M1	1 ~ 230	50 / 60	22	0.12
BN 80	M2			22	0.12
BN 90	—			40	0.30
BN 100	M3	3 ~ 230 Δ / 400Y		40	0.12 / 0.09
BN 112	—			50	0.26 / 0.15
BN 132 ... BN 160MR	M4			110	0.38 / 0.22
		V a.c. \pm 10%	Hz	P [W]	I [A]
BE 80	ME2	1 ~ 230	50 / 60	22	0.12
BE 90	—			40	0.30
BE 100	ME3	3 ~ 230 Δ / 400Y		40	0.12 / 0.09
BE 112	—			50	0.26 / 0.15
BE 132	ME4			110	0.38 / 0.22

4.5 Direction of rotation

If the mains with phase sequence L1, L2, L3 is connected to terminals U, V, W, the direction of rotation of the motor will be clockwise as seen from the drive end.

If any two terminals are switched, the direction of rotation will be counter-clockwise.

For unidirectional motors, a plate will be provided indicating the direction of rotation and the phase sequence to be applied (e.g., U, V, W).

This indication is present only when the motor, as a function of project characteristics, requires only one direction of rotation (for example, anti run-back device installed).

Pay special attention when single direction status is imposed by machine or plant specifications.

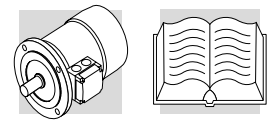

4.6 FD brake connections

On standard single-pole motors, the rectifier is connected to the motor terminal board at the factory.

For switch-pole motors and where a separate brake power supply is required, connection to rectifier must comply with brake voltage VB stated in motor name plate.

Because the load is of the inductive type, brake control and DC line interruption must use contacts from the usage class AC-3 to IEC 60947-4-1.

Scheme (A) - Brake power supply from motor terminals and a.c. line disconnection. Delayed stop time t_2 and function of motor time constants. Mandatory when soft-start/stops are required.

Scheme (B) - Separate supply of brake coil and a.c. line disconnect. Regular stopping time, independent on time constants of motor.

Scheme (C) - Brake coil power supply from motor terminals and AC/DC line disconnection.

Scheme (D) - Brake coil with separate power supply and AC/DC line disconnection.

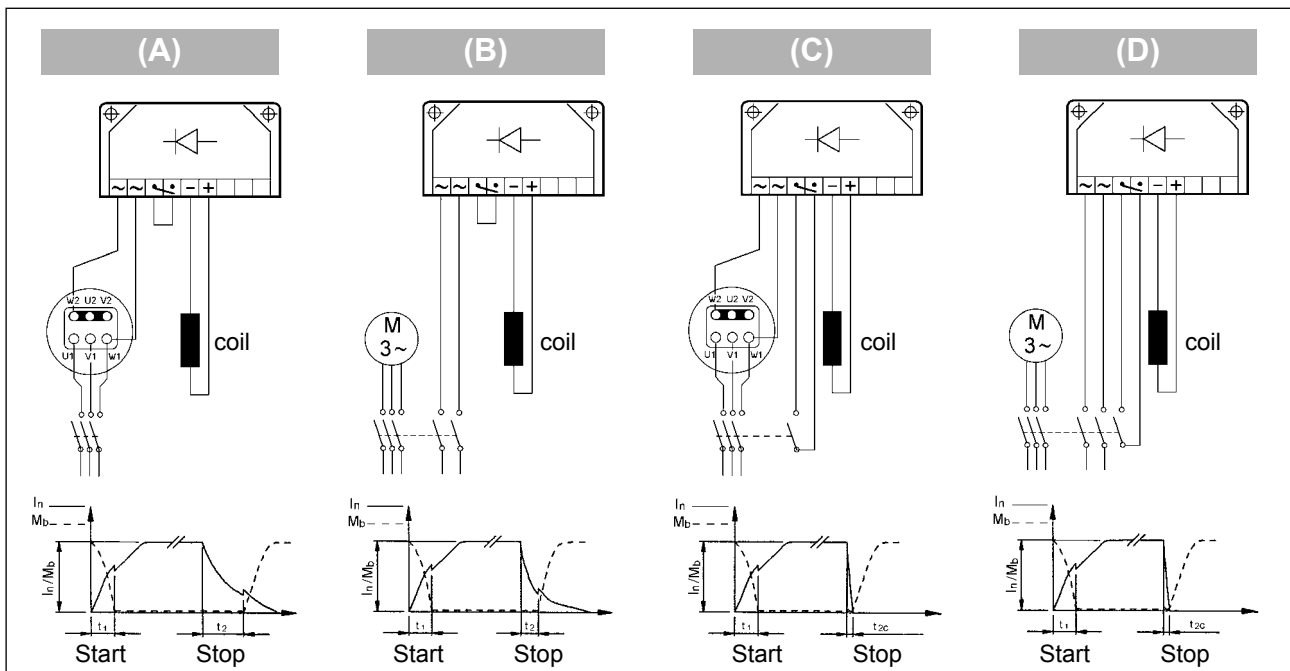

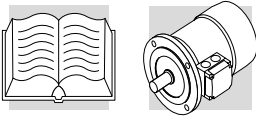

4.7 FDD brake connections

Whenever a separate brake power supply is required (e.g., for inverter operation), the connection to the rectifier must comply with the brake winding voltage stated on the motor nameplate.

Because of the highly inductive load, contacts used for brake control must belong to usage class AC-3 (for AC line interruption) or DC-13 (for DC line interruption) according to IEC 60947-4-1.

Scheme (A) – Brake coil with separate power supply and NR rectifier, a.c. line interruption.

Scheme (B) – Brake coil with separate power supply and NR rectifier, a.c. and d.c. lines interruption.

Scheme (C) – Brake coil with separate power supply and SR electronic rectifier, with integrated overexcitation and fast switching.

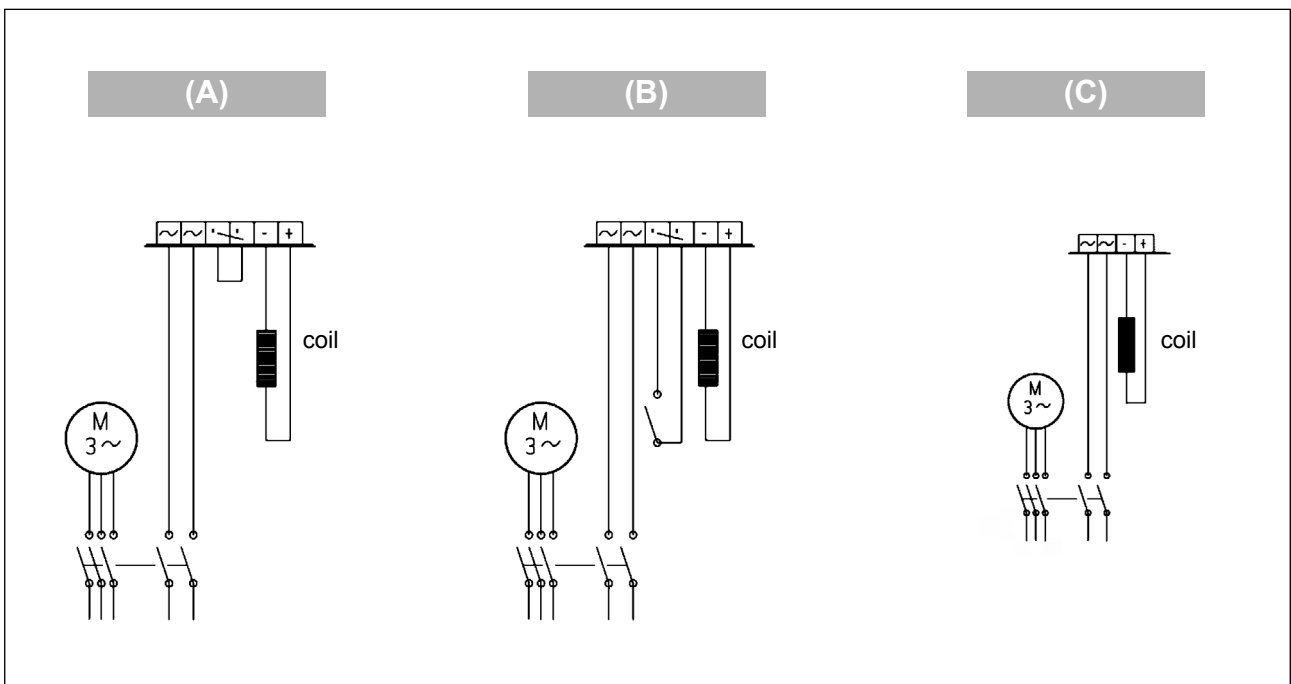

Direct connection of the brake through motor terminals is feasible by selecting an SA motor supply, provided the wiring is managed and motor/brake voltage compatibility is ensured

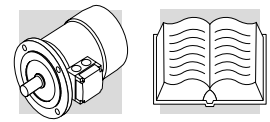

4.8 FDD direct connection through motor terminals with NR rectifier

Motor size	Motor Supply (Grid) [Vac] (Phase-phase)					NR - STANDARD PERFORMANCE					
						Equivalent SA [Vac]					
	WD/Hz	$\Delta\Delta$	YY	Δ	Y	$\Delta\Delta$ (T1-T2)	YY (T1-T10)	YY (T1-T2)	Δ (T1-T2)	Y (T1-T10)	Y (T1-T2)
BXN 63/71/80 MXN 05/10/20	WD1-50	115	200	230	400	115	115	200	230	230	400
	WD1-60	132	230	265	460	127	127	230	240	240	460
	WD3-50	110	190	220	380	110	110	208	220	220	380
	WD3-60	127	220	255	400	127	127	220	240	240	400
	WD4-50	95	165	190	330	-	-	-	208	208	330
	WD4-60	110	190	220	380	110	110	208	220	220	380
	WD5-50	120	208	240	415	120	120	208	240	240	415
	WD5-60	140	240	280	480	127	127	240	-	-	480
	WD7-50	147	255	290	500	-	-	240	-	-	480
WD7-60	165	290	330	575	-	-	-	330	330	-	
BXN 90/100/112 MXN 25/30/35	WD1-50	115	200	230	400	115	115	200	230	230	400
	WD1-60	132	230	265	460	127	127	230	240	240	460
	WD2-50	200	346	400	690	200	200	380	400	400	-
	WD2-60	230	400	460	\	230	230	400	460	460	-
	WD3-50	110	190	220	380	110	110	208	220	220	380
	WD3-60	127	220	255	400	127	127	220	240	240	400
	WD4-50	95	165	190	330	-	-	-	208	208	330
	WD4-60	110	190	220	380	110	110	208	220	220	380
	WD5-50	120	208	240	415	120	120	208	240	240	415
	WD5-60	140	240	280	480	127	127	240	-	-	480
	WD6-50	208	360	415	720	208	208	400	415	415	-
	WD6-60	240	415	480	\	240	240	415	480	480	-
WD7-50	147	255	290	500	-	-	240	-	-	480	
WD7-60	165	290	330	575	-	-	-	330	330	-	
BXN 132 MXN 40	WD2-50	200	346	400	690	200	200	380	400	400	-
	WD2-60	230	400	460	\	230	230	400	460	460	-
	WD6-50	208	360	415	720	208	208	400	415	415	-
	WD6-60	240	415	480	\	240	240	415	480	480	-
	WD8-50	230	400	460	\	230	230	400	460	460	-
	WD8-60	265	460	530	\	240	240	460	480	480	-
	WD9-50	220	380	440	\	220	220	380	440	440	-
	WD9-60	255	440	510	\	240	240	440	480	480	-
	WD10-50	190	330	380	660	208	208	330	380	380	-
	WD10-60	220	380	440	\	220	220	380	440	440	-
	WD11-50	240	415	480	\	240	240	415	480	480	-
	WD11-60	280	480	550	\	-	-	480	-	-	-
	WD12-50	290	500	575	\	-	-	480	-	-	-
WD12-60	330	575	\	\	330	330	-	-	-	-	

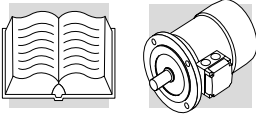

4.9 FDD direct connection through motor terminals with SR rectifier

Motor size	Motor Supply (Grid) [Vac] (Phase-phase)					SR - FAST PERFORMANCE					
						Equivalent SA [Vac]					
	WD/Hz	$\Delta\Delta$	YY	Δ	Y	$\Delta\Delta$ (T1-T2)	YY (T1-T10)	YY (T1-T2)	Δ (T1-T2)	Y (T1-T10)	Y (T1-T2)
BXN 63/71/80 MXN 05/10/20	WD1-50	115	200	230	400	115	115	200	230	230	400
	WD1-60	132	230	265	460	-	-	230	330	330	460
	WD3-50	110	190	220	380	110	110	240	220	220	380
	WD3-60	127	220	255	400	127	127	220	330	330	400
	WD4-50	95	165	190	330	127	127	230	240	240	330
	WD4-60	110	190	220	380	110	110	240	220	220	380
	WD5-50	120	208	240	415	120	120	208	240	240	415
	WD5-60	140	240	280	480	200	200	240	400	400	480
	WD7-50	147	255	290	500	208	208	330	400	400	-
WD7-60	165	290	330	575	230	230	400	330	330	-	
BXN 90/100/112 MXN 25/30/35	WD1-50	115	200	230	400	115	115	200	230	230	400
	WD1-60	132	230	265	460	-	-	230	330	330	460
	WD2-50	200	346	400	690	200	200	480	400	400	-
	WD2-60	230	400	460	\	230	230	400	460	460	-
	WD3-50	110	190	220	380	110	110	240	220	220	380
	WD3-60	127	220	255	400	127	127	220	330	330	400
	WD4-50	95	165	190	330	127	127	230	240	240	330
	WD4-60	110	190	220	380	110	110	240	220	220	380
	WD5-50	120	208	240	415	120	120	208	240	240	415
	WD5-60	140	240	280	480	200	200	240	400	400	480
	WD6-50	208	360	415	720	208	208	480	415	415	-
	WD6-60	240	415	480	\	240	240	415	480	480	-
WD7-50	147	255	290	500	208	208	330	400	400	-	
WD7-60	165	290	330	575	230	230	400	330	330	-	
BXN 132 MXN 40	WD2-50	200	346	400	690	200	200	480	400	400	-
	WD2-60	230	400	460	\	230	230	400	460	460	-
	WD6-50	208	360	415	720	208	208	480	415	415	-
	WD6-60	240	415	480	\	240	240	415	480	480	-
	WD8-50	230	400	460	\	230	230	400	460	460	-
	WD8-60	265	460	530	\	330	330	460	-	-	-
	WD9-50	220	380	440	\	220	220	380	440	440	-
	WD9-60	255	440	510	\	330	330	440	-	-	-
	WD10-50	190	330	380	660	240	240	330	380	380	-
	WD10-60	220	380	440	\	220	220	380	440	440	-
	WD11-50	240	415	480	\	240	240	415	480	480	-
	WD11-60	280	480	550	\	400	400	480	-	-	-
WD12-50	290	500	575	\	400	400	-	-	-	-	
WD12-60	330	575	\	\	330	330	-	-	-	-	

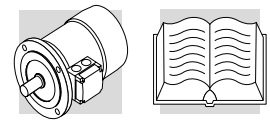

5 START-UP

Perform the following operations and checks before start-up:

- 1) check that all safety measures have been applied;
- 2) power up the motor unloaded at rated voltage;
- 3) check that the separate fan cooling (if any) is operating;
- 4) check that operation is smooth and vibration-free;
- 5) If the brake is fitted, verify that it operates regularly;
- 6) if operation is satisfactory, apply the load to the motor while checking on values of absorbed current, power and voltage.



Abnormal operations such as over current, overheating, noise, or vibrations, may cause serious damage or hazardous conditions. In these cases, cut power and notify maintenance personnel immediately.

6 MAINTENANCE

Before any intervention, the motor, auxiliary circuits and/or accessories must be disconnected from the mains.

In particular:

- check disconnection from the electrical mains,
- provide suitable protections from exposed live parts,
- double check that accidental restarts are not possible under any circumstances.

It is recommended that periodical checks of motor operating conditions are scheduled as a routine maintenance practice.

Check particularly on the following:

- 1) check that operation is smooth and absorbed current within rated value;
- 2) On brakemotors, check condition of the brake, gauge the air gap "T" and play "X" of the manual brake release device; when provided
- 3) keep motor clean and fan cowl unobstructed by accumulation of dust or foreign particles;
- 4) check that seal rings are in good condition;
- 5) check that lead-in wires and all wirings are safely and tightly secured;
- 6) If condensate draining holes are provided, remove periodically the screws that close the holes and allow the condensate to drain. On installing the motor make sure that the drain hole is located at the lowest point.
- 7) standard bearings are grease packed for life and in general no periodical maintenance is required; it is good practice however to check their condition and eventually replace them after approx. 3 years.

The motor does not have to be removed for normal inspections unless the bearings need to be replaced. In this case, the operations should be performed by specialised personnel and with appropriate tools.

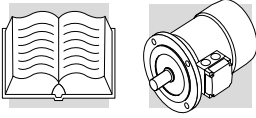

6.1 Adjustment of air gap on motors with d.c. brake FD

Loosen nut ref. 2

Depending on motor frame size adjust the air gap and set dimension T to the min. value indicated in diagram through either socket head screws ref. (1) or nut ref. (3).

Then after hold firmly screw ref. (1) and lock it by tightening nut ref.(2).

Check the air gap periodically and re-adjust it if dimension T is found exceeding the min/max values indicated in diagram.

Particularly, brake may become noisier if gap is wider than the max value. In extreme cases releasing of the brake might also be affected.

If the brake disengagement device is fitted, too wide a gap may lead the braking torque to drop significantly as a consequence of the reduced play in the release mechanism.

Distance “X” must mandatorily be equal to or greater than the value listed in the chart.

Thickness of disc lining must always be greater than 1.5 mm.

FD		BRAKE TYPE							
		FD 02	FD 03 FD 53	FD 04 FD 14	FD 05 FD 15 FD 55	FD 06S	FD 06 FD 56	FD 07	FD 08 FD 09
T	Min	0.2	0.2	0.3	0.3	0.35	0.35	0.4	0.5
	Max	0.5	0.5	0.6	0.6	0.7	0.7	0.8	1.0
X	≥	0.8	0.8	1.0	1.0	1.1	1.1	1.2	1.5

T (mm) = Air gap

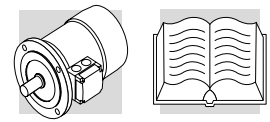

6.2 Adjustment of air gap on motors with D.C. brake FDD

Loosen the socket head cap screws ref.1 slightly

Turn the sleeve bolts ref.2 in CW to increase in T and CCW to decrease T using a wrench (using an open-end wrench). A 1/6 turn CCW will decrease the air gap by approximately 0.15 m.

Depending on motor frame size adjust the air gap and set dimension T to the min. value indicated in Table 2 through either socket head screws ref. (1)

Then after hold firmly the socket head cap screw ref. (1) tighten it using torque wrench

Check the air gap periodically and re-adjust it if dimension T is found exceeding the min/max values indicated in diagram.

Particularly, brake may become noisier if gap is wider than the max value. In extreme cases releasing of the brake might also be affected.

If the brake disengagement device is fitted, too wide a gap may lead the braking torque to drop significantly as a consequence of the reduced play in the release mechanism.

Distance “X” must mandatorily be equal to or greater than the value listed in the chart.

Thickness of disc lining must always be greater than Min.Thickness value listed in Table 1.

Table 1

Brake	Min thickness	Max thickness
FDD 06S	4.5	6.0
FDD 06	4.5	6.0
FDD 08	5.5	7.0
FDD 10	7.5	9.0
FDD 12	8.0	10
FDD 14	7.5	10
FDD 16	8.0	11.5

Table 2

BRAKE TYPE					
FD		Operating brake		Holding brake	
		FDD 06S FDD 06 FDD 08 FDD 10	FDD 12 FDD 14 FDD 16	FDD 06S FDD 06 FDD 08 FDD 10	FDD 06S FDD 06 FDD 08 FDD 10
T	Min	0.2	0.3	0.2	0.3
	Max	0.5	0.75	0.3	0.45
X	≥	1.0	1.5	1.0	1.5

T (mm) = Air gap

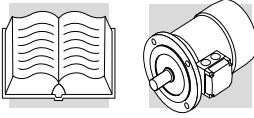

7 DISASSEMBLY, RECYCLING OR DISPOSAL

The electrical motors are mainly made by ferrous, non - ferrous, plastic materials and electric / electronic devices.

Bonfiglioli recommends and encourages the end of life motor dismantling and the differentiation and recycling of the components.

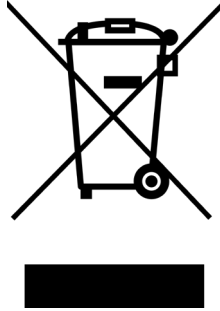

This product should not be mixed with general household waste. Disposal has to be carried out in conformity with EU Directive 2012/19/EU where established, and in accordance to national regulations.

Fulfill disposal in accordance with any other legislation in force throughout the country.

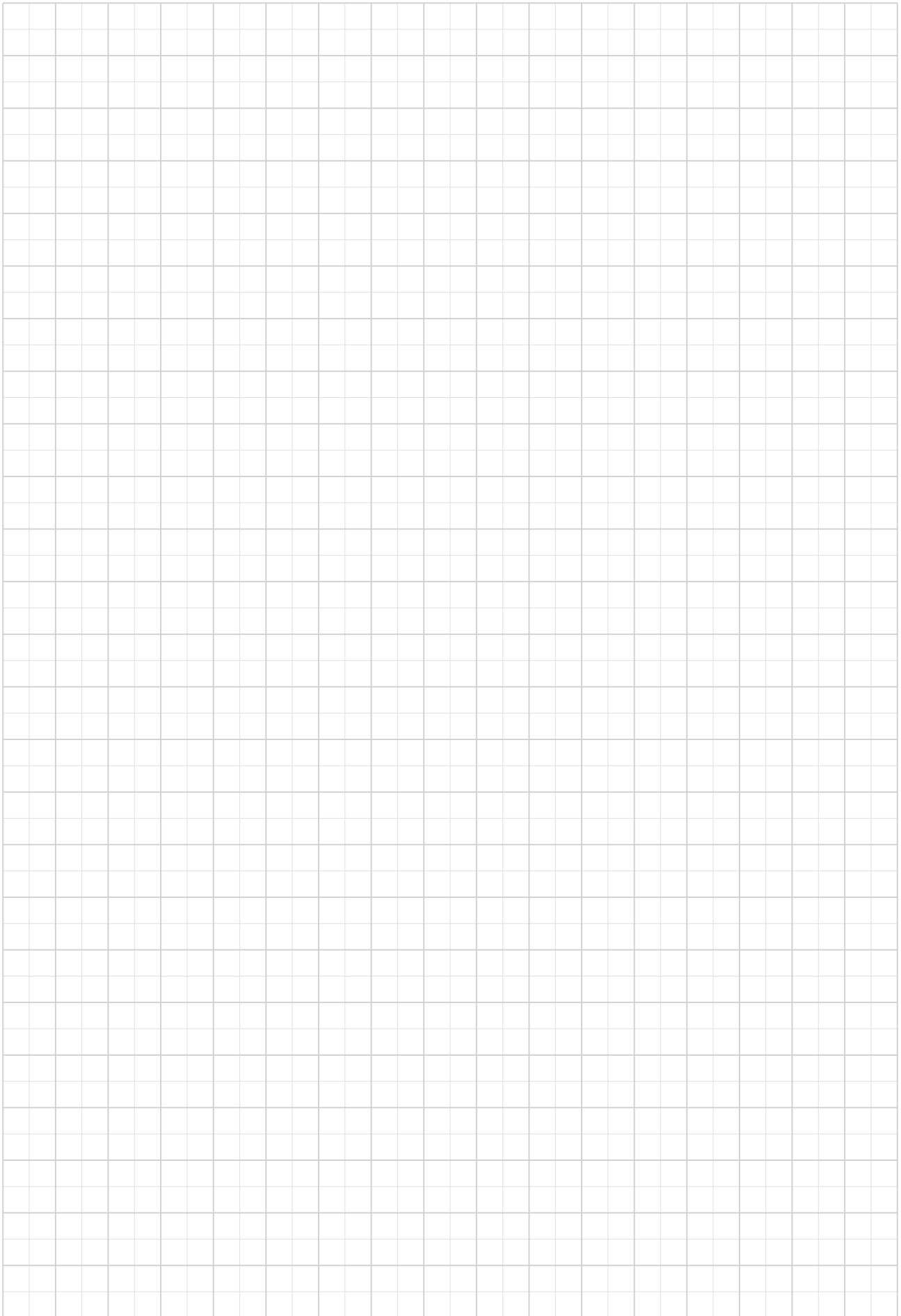
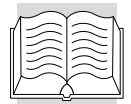
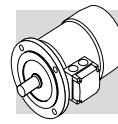

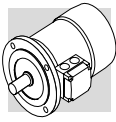

8 SPARE PARTS

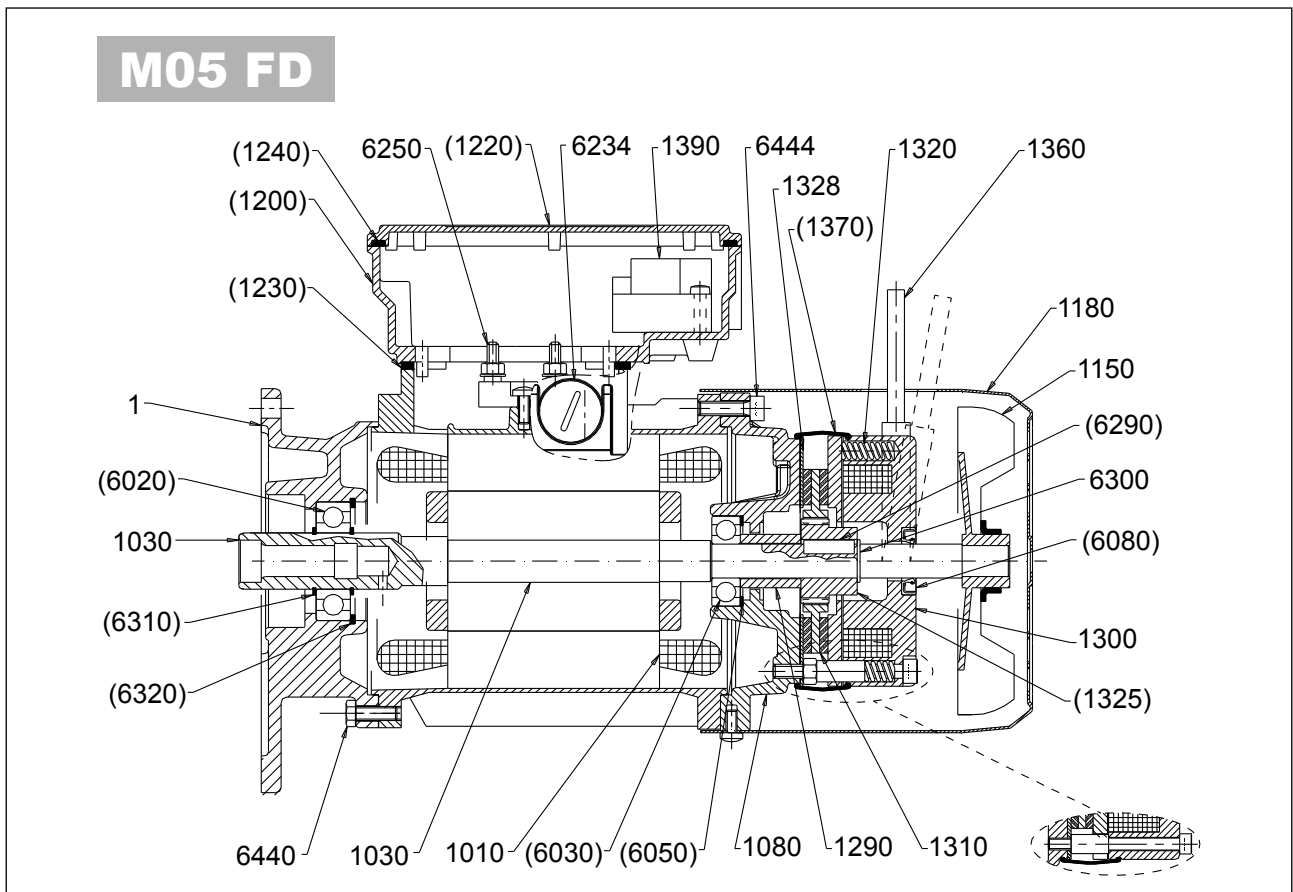
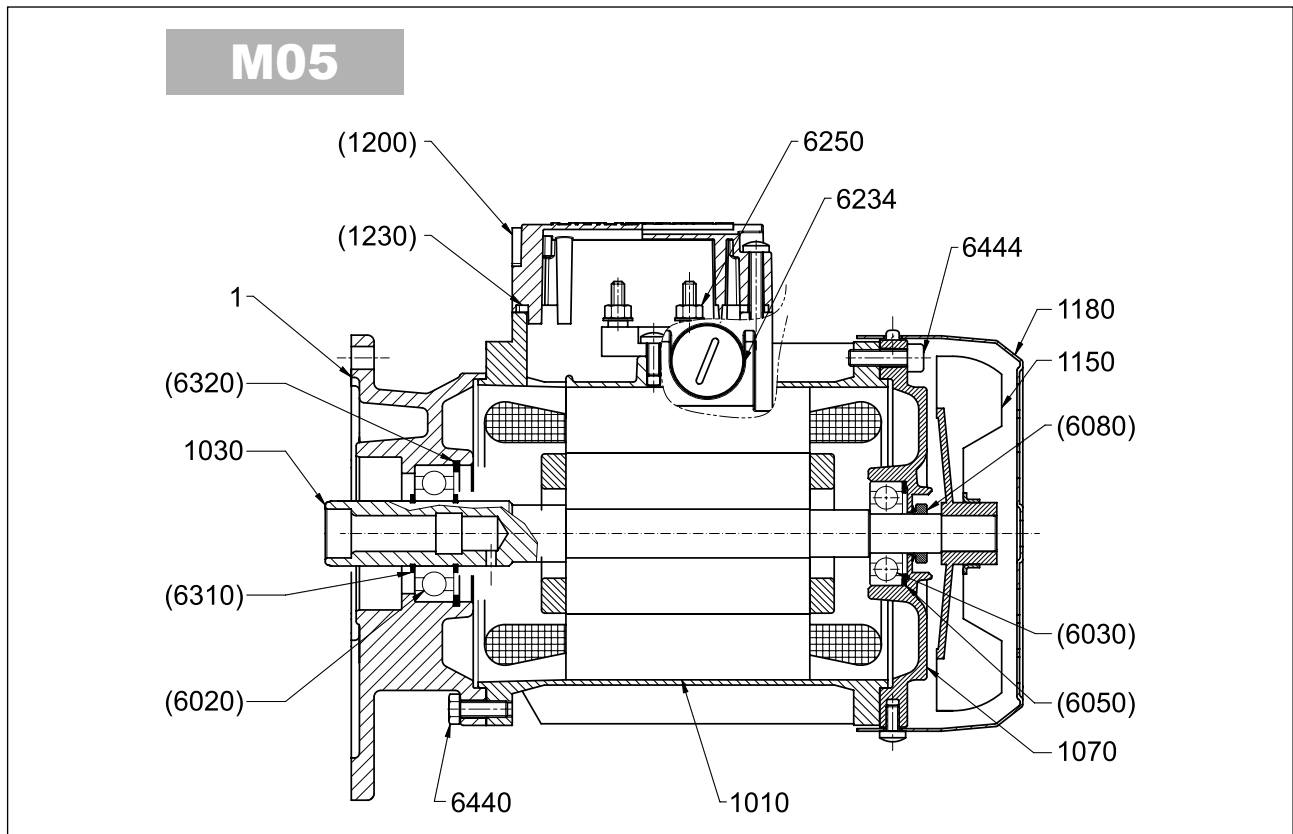

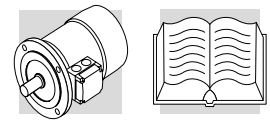

	kit	ref.	Description
M05 M05 FD		1	Motor flange
		1010	Stator
		1030	Rotor
		1150	Fan
		1180	Fan cowl
	KSM	(1200)	Terminal box
		(1230)	Terminal box gasket
	KSA	(6020)	Bearing
		(6030)	Bearing
		(6050)	Compensation ring
		(6310)	Circlip
		(6320)	Circlip
		6234	Blank plug
		6250	Terminal board
		6440	Flange bolt
	6444	NDE shield bolt	
M05		1070	Rear shield
	KSA	(6080)	V-ring

	kit	ref.	Description
M05 FD		1080	Shield for brake motor
		1290	Spacer ring
		1310	Brake disc
		1320	Brake springs
		(1325)	Brake hub
	KTF	(6290)	Key (brake hub)
		(6300)	Circlip
		1328	Stainless steel disc
	KPF	(1370)	Water/dust guard (IP55)
		(6080)	Brake seal ring/V-ring (IP55)
M05 FD	KSM	(1220)	Terminal box lid
		(1240)	Terminal box lid gasket
		1300	d.c. brake type FD
		1360	Brake release
		1390	ac/dc rectifier

(####) Only available as a complete kit

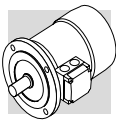

M1 ... M4

ME2 ... ME4

MX2 ... MX4

M_

ME_

MX_

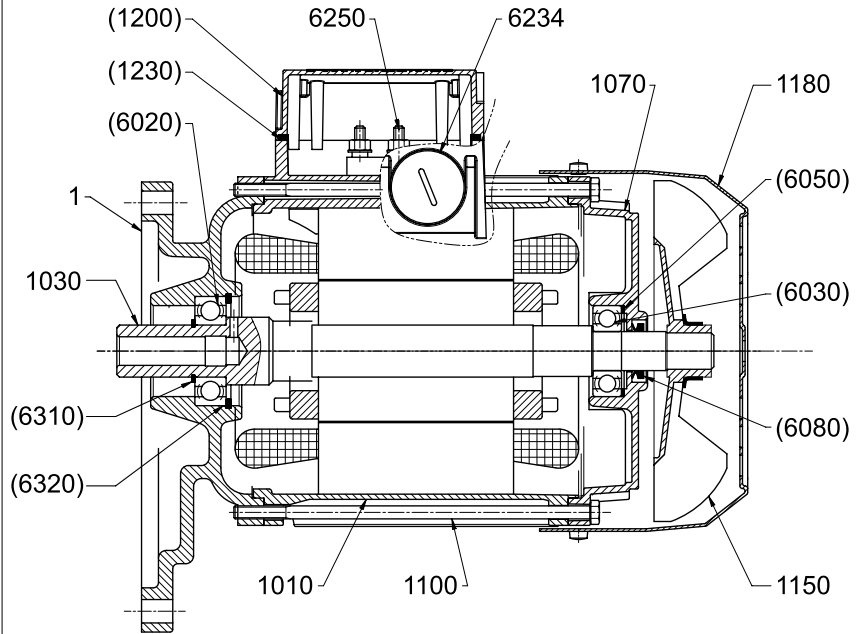
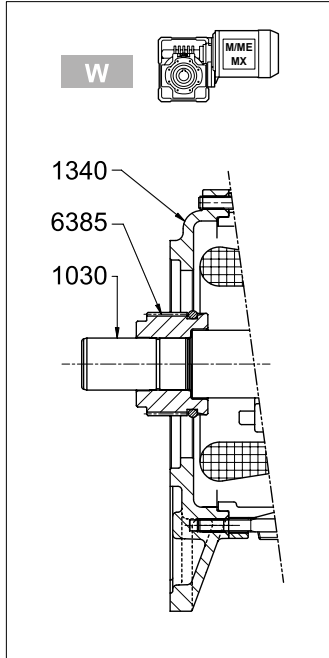

M_ FD

ME_ FD

MX_ FD

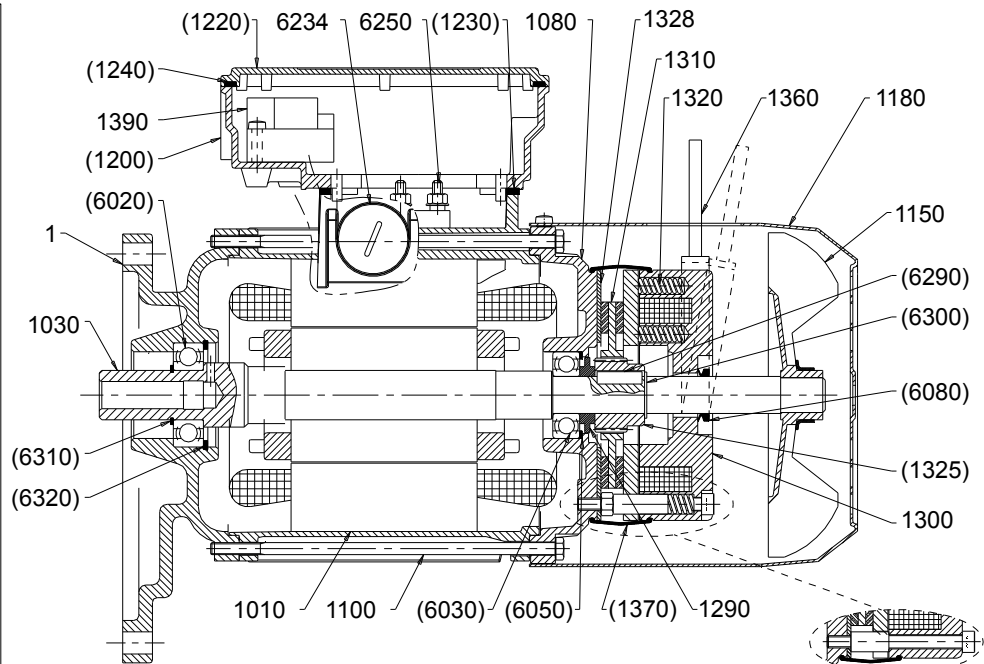
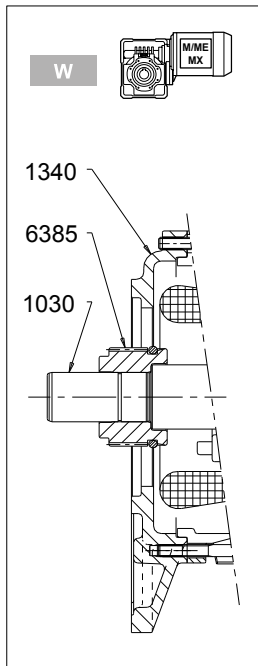

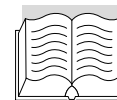
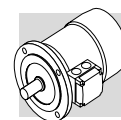

	kit	ref.	Description
M_		1	Motor flange
		1010	Stator
		1030	Rotor
		1100	Tie-rods
		1150	Fan
		1180	Fan cowl
M_ M_ FD	KSM	(1200)	Terminal box
		(1230)	Terminal box gasket
ME_ ME_ FD		1340	Motor flange for W gearbox
	KSA	(6020)	Bearing
(6030)		Bearing	
(6050)		Compensation ring	
(6310)		Circlip	
(6320)		Circlip	
MX_ MX_ FD		6234	Blank plug
		6250	Terminal board
		6385	Kit bushing for W gearbox
M_ / ME_ MX_		1070	Rear shield
	KSA	(6080)	V-ring

	kit	ref.	Description
M_ FD		1080	Shield for brake motor
		1290	Spacer ring
		1310	Brake disc
		1320	Brake springs
ME_ FD	KTF	(1325)	Brake hub
		(6290)	Key (brake hub)
MX_ FD	KPF	(6300)	Circlip
		(1370)	Water/dust guard (IP55)
M_ FD ME_ FD MX_ FD	KSM	(6080)	Brake seal ring/V-ring (IP55)
		(1220)	Terminal box lid
		(1240)	Terminal box lid gasket
		1300	d.c. brake type FD
		1328	Stainless steel disc
	1360	Brake release kit	
	1390	ac/dc rectifier	

(####) Only available as a complete kit

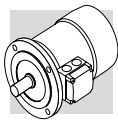

M5

ME5

MX5

M5

ME5

MX5

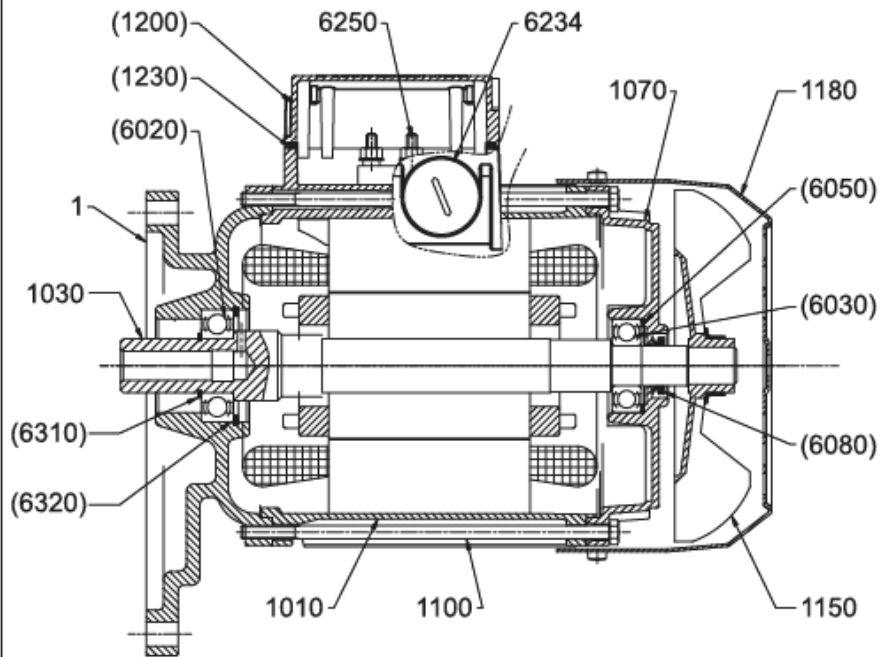
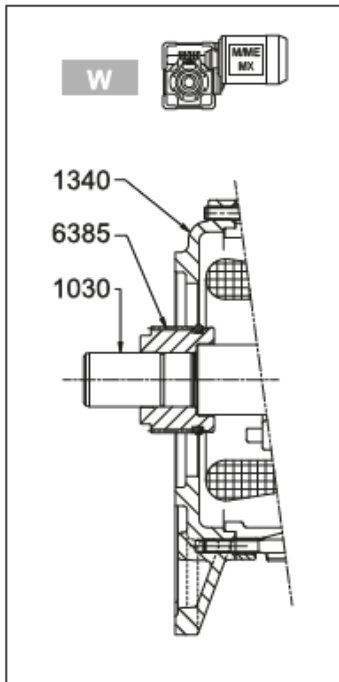

M5 FD

ME5 FD

MX5 FD

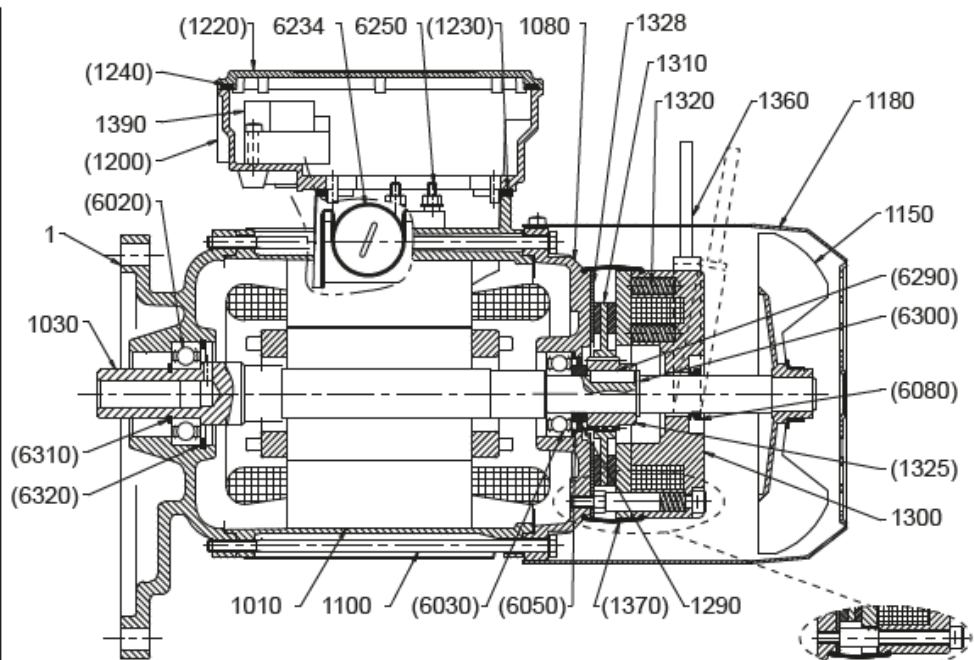
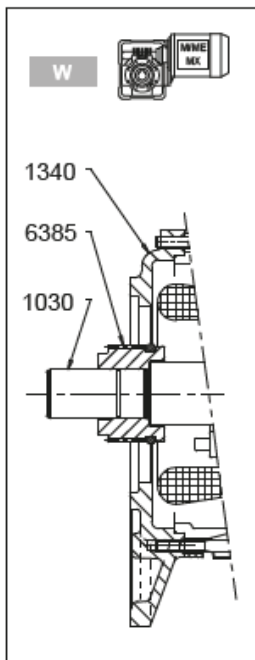

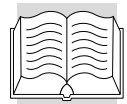
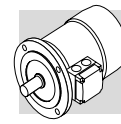

	kit	ref.	Description
M5 M5 FD ME5 ME5 FD MX5 MX5 FD		1	Motor flange
		1010	Stator
		1030	Rotor
		1150	Fan
		1180	Fan cowl
	KSM	(1200)	Terminal box
		(1220)	Terminal box lid
		(1230)	Terminal box gasket
		(1240)	Terminal box lid gasket
	KSA	(6020)	Bearing
		(6030)	Bearing
		(6050)	Compensation ring
		(6310)	Circlip
		(6320)	Circlip
		6234	Blank plug
		6250	Terminal board
		6440	Flange bolt
	6448	NDE shield bolt	

	kit	ref.	Description
M5 / ME5 MX5		1070	Rear shield
	KSA	(6080)	V-ring
M5 FD ME5 FD MX5 FD		1080	Shield for brake motor
		1310	Brake disc
		1320	Brake springs
	KTF	(1325)	Brake hub
		(6045)	Spacer
		(6290)	Key (brake hub)
		(6300)	Circlip
	KPF	(1370)	Water/dust guard (IP55)
		(6080)	Brake V-ring (IP55)
	M5 FD ME5 FD MX5 FD		1300
	1328	Stainless steel disc (IP55)	
	1360	Brake release	
	1390	ac/dc rectifier	

(####) Only available as a complete kit

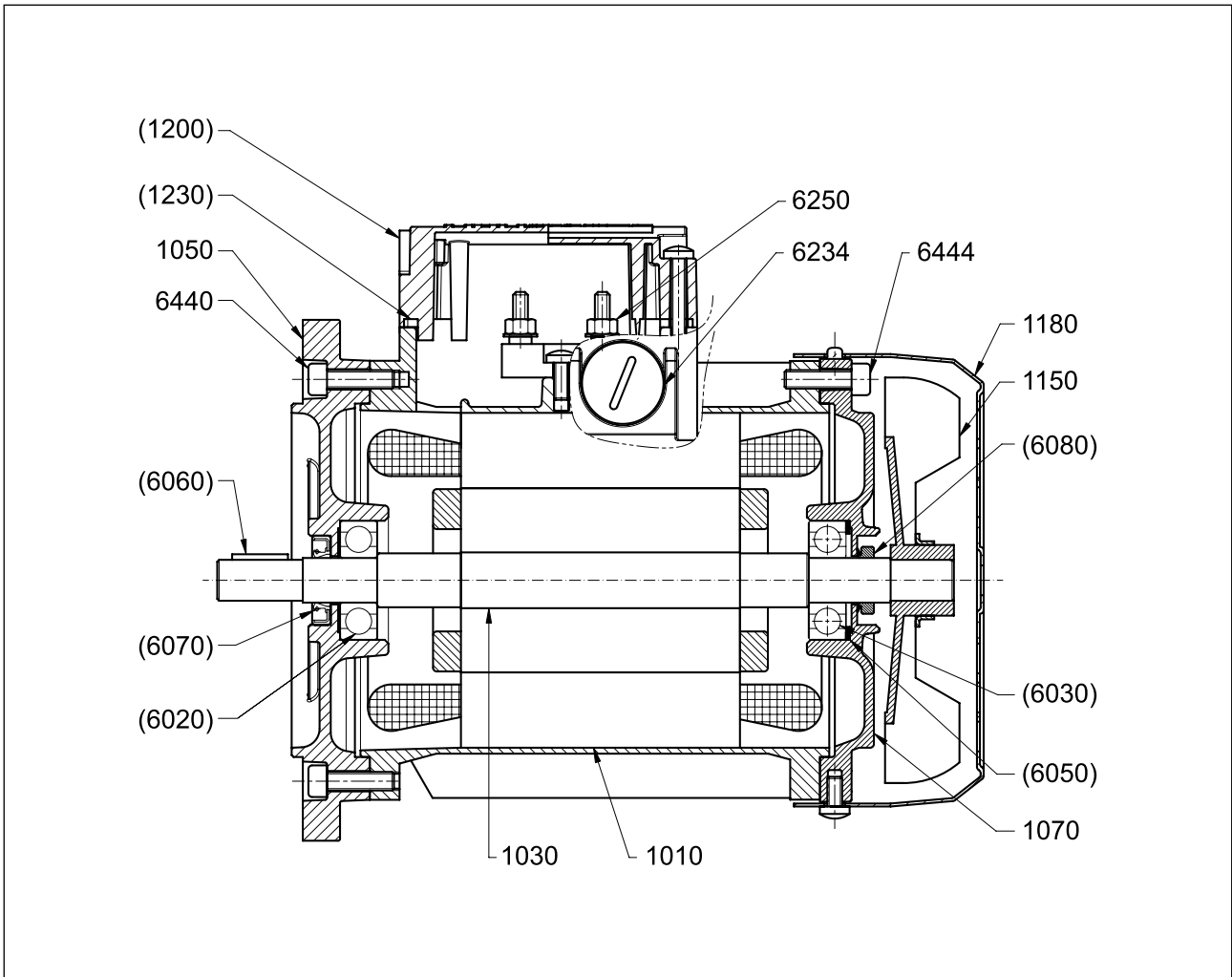
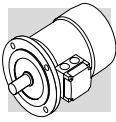

kit	ref.	Description
	1010	Stator winding complete
	1030	Rotor shaft
	1050	Mounting flange (IM B5/IM B14)
	1070	Rear shield
	1150	Fan
	1180	Fan cover
KSM	(1200)	Terminal box lid
	(1230)	Terminal box gasket
	6234	Blank plug

kit	ref.	Description
	6250	Terminal board
	6440	Flange bolt
	6444	NDE shield bolt
KSA	(6020)	Bearing
	(6030)	Bearing
	(6050)	Compensation ring
	(6060)	Key
	(6070)	Seal ring
	(6080)	V-ring

(####) Only available as a complete kit

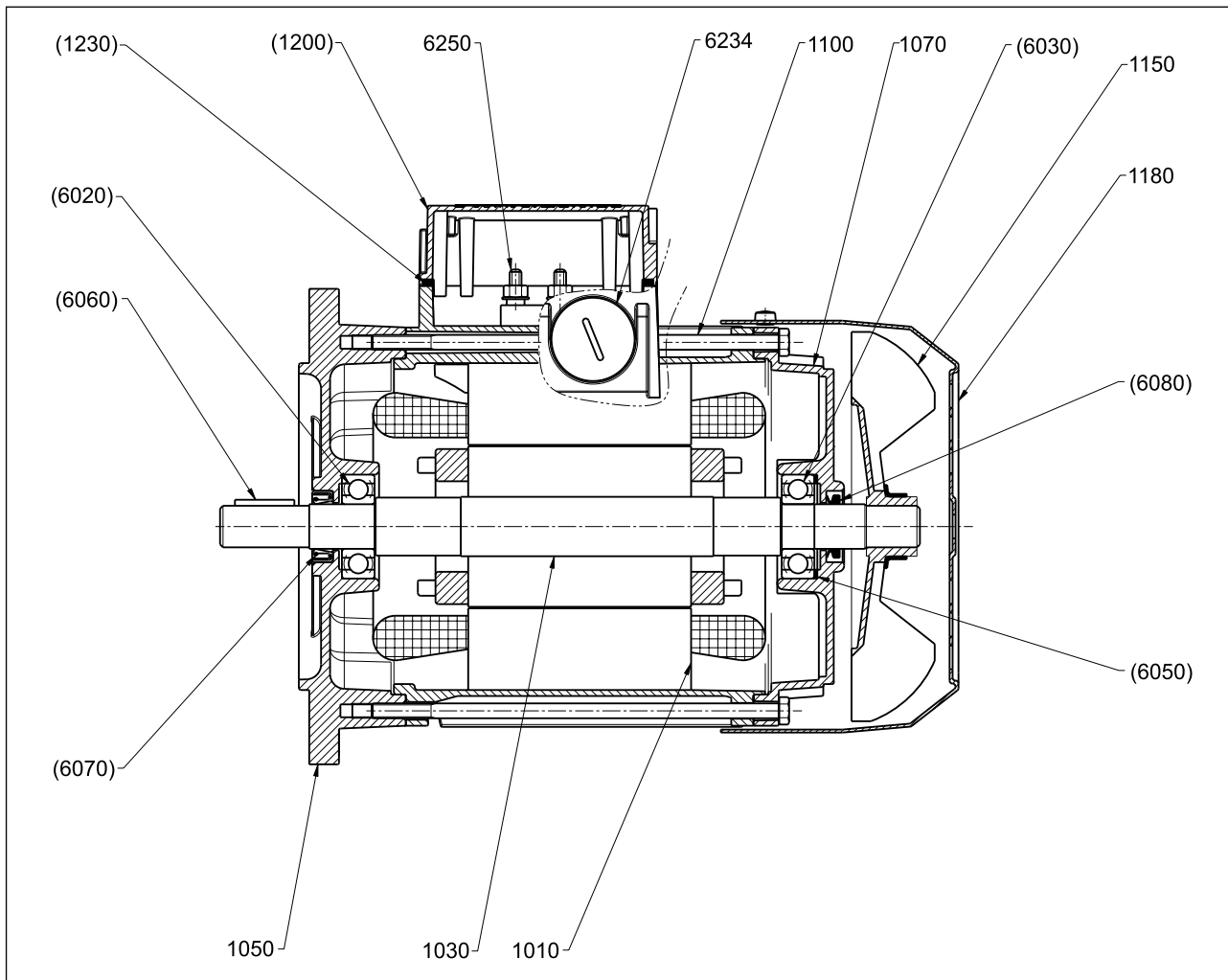
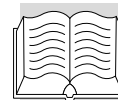
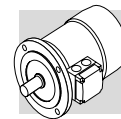

kit	ref.	Description
	1010	Stator winding complete
	1030	Rotor shaft
	1050	Mounting flange (B5/B14)
	1070	Rear shield
	1100	Tie-rods
	1150	Fan
	1180	Fan cover
KSM	(1200)	Terminal box lid
	(1230)	Terminal box gasket

kit	ref.	Description
	6234	Blank plug
	6250	Terminal board
KSA	(6020)	Bearing
	(6030)	Bearing
	(6050)	Compensation ring
	(6060)	Key
	(6070)	Seal ring
	(6080)	V-ring

(####) Only available as a complete kit

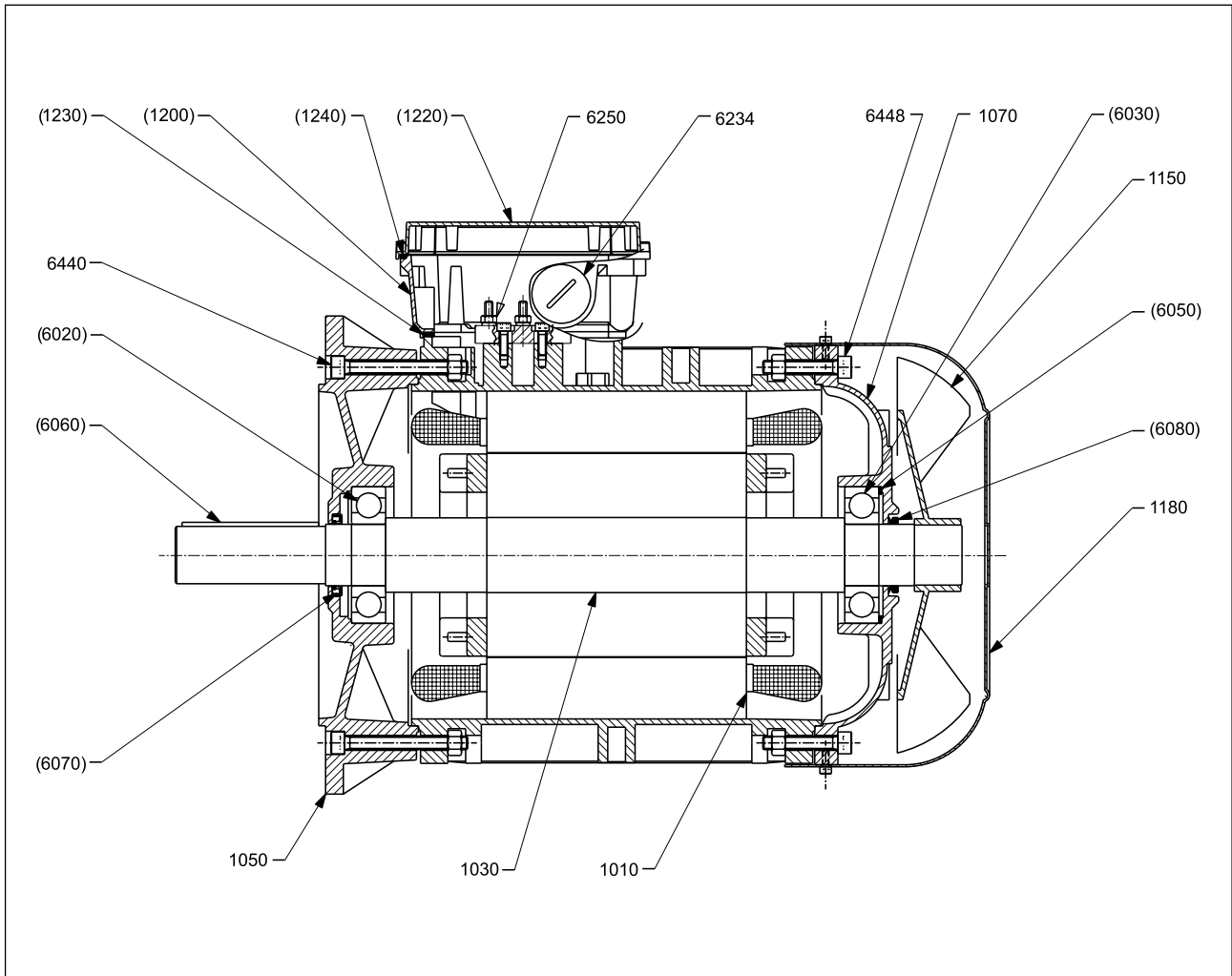
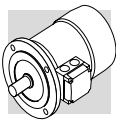
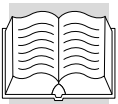

kit	ref.	Description
	1010	Stator winding complete
	1030	Rotor shaft
	1050	Mounting flange (IM B5)
	1070	Rear shield
	1150	Fan
	1180	Fan cover
KSM	(1200)	Terminal box
	(1220)	Terminal box lid
	(1230)	Terminal box gasket
	(1240)	Lid gasket

kit	ref.	Description
	6234	Blank plug
	6250	Terminal board
	6440	DE flange bolts
	6448	NDE shield bolts
KSA	(6020)	Bearing
	(6030)	Bearing
	(6050)	Compensation ring
	(6060)	Key
	(6070)	Seal ring
	(6080)	V-ring

(####) Only available as a complete kit

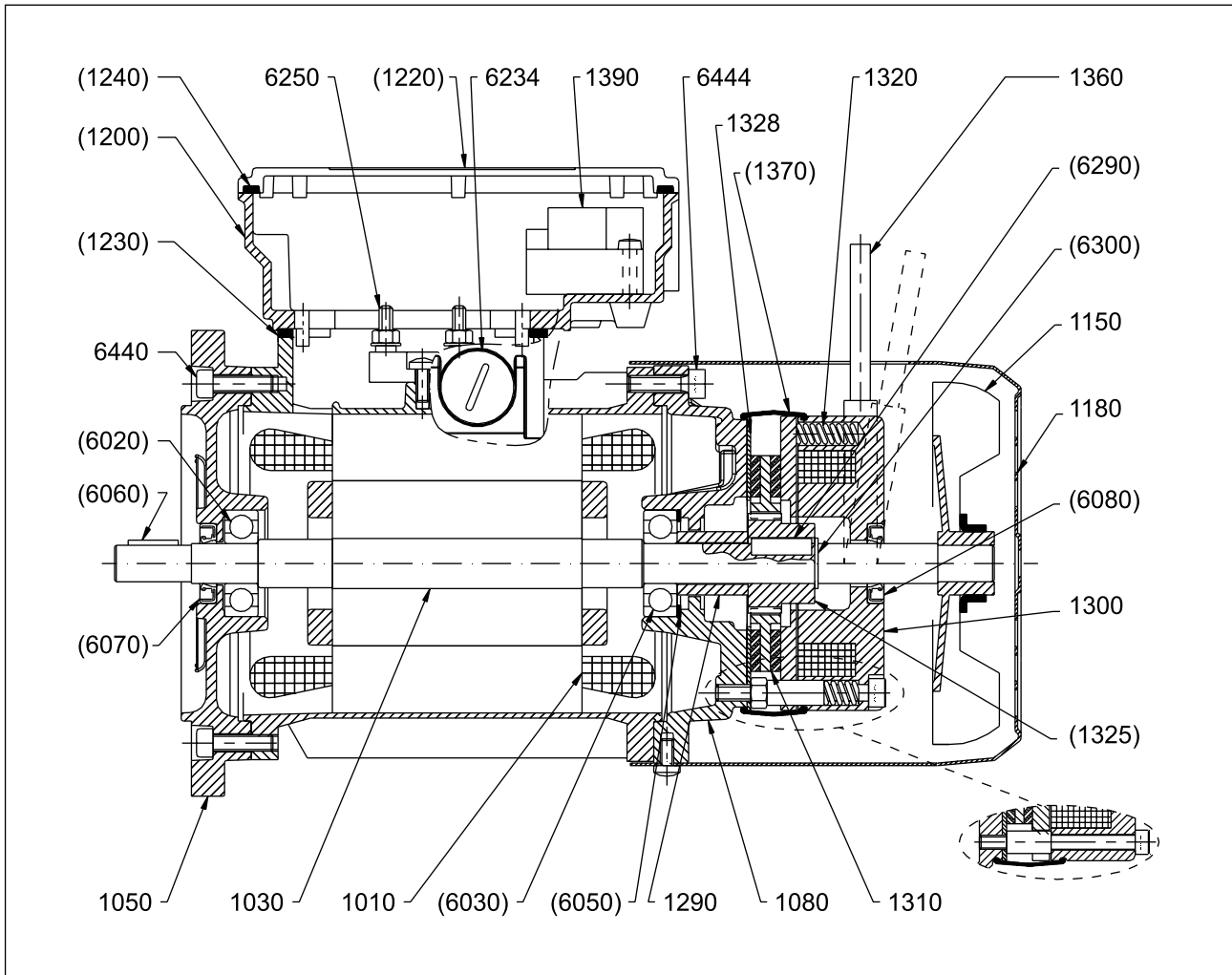
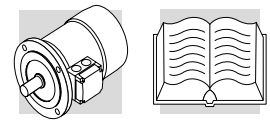

kit	ref.	Description
	1010	Stator winding complete
	1030	Rotor shaft
	1050	Mounting flange (B5/B14)
	1080	Rear shield
	1150	Fan
	1180	Fan cover
KSM	(1200)	Terminal box
	(1220)	Terminal box lid
	(1230)	Terminal box gasket
	(1240)	Lid gasket
	1290	Spacer ring
	1300	d.c. brake type FD
	1310	Brake disc
	1320	Brake springs
KTF	(1325)	Brake hub
	(6290)	Key (brake hub)
	(6300)	Circlip

kit	ref.	Description
	1328	Stainless steel disc (IP55)
	1360	Hand release lever
KPF	(1370)	Grommet (IP55)
	(6080)	V-ring (IP55)
	1390	ac/dc rectifier
KSA	(6020)	Bearing
	(6030)	Bearing
	(6050)	Compensation ring
	(6060)	Key
	(6070)	Seal ring
	6234	Blank plug
	6250	Terminal board
	6440	Flange bolt
	6444	NDE shield bolts

(####) Only available as a complete kit

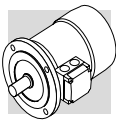
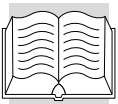

BN 71 FD ... BN 160MR FD

BE 80 FD ... BE 132 FD

BX 80 FD ... BX 132 FD

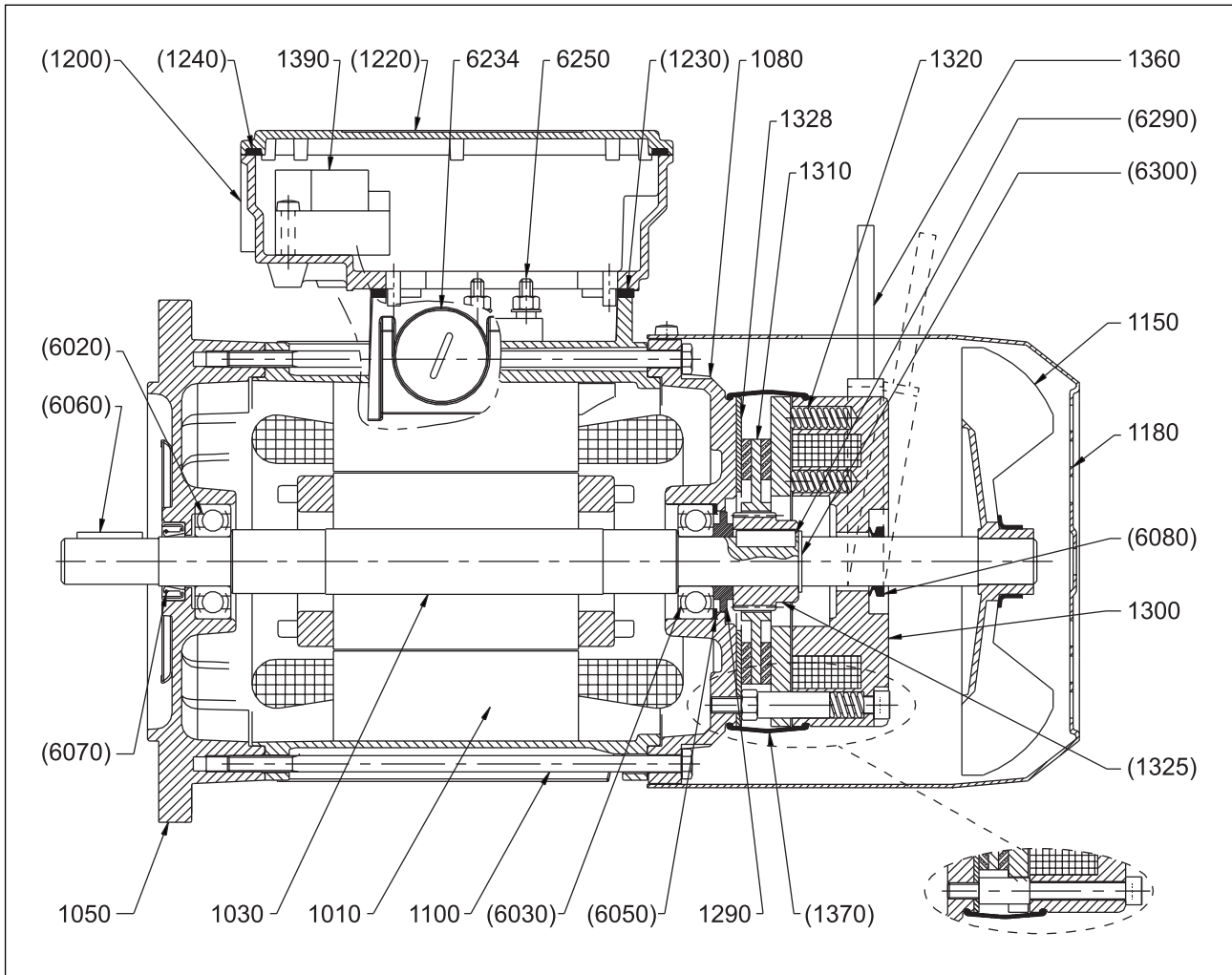

kit	ref.	Description
	1010	Stator winding complete
	1030	Rotor shaft
	1050	Mounting flange (B5/B14)
	1080	Rear shield
	1100	Tie-rods
	1150	Fan
	1180	Fan cover
KSM	(1200)	Terminal box
	(1220)	Terminal box lid
	(1230)	Terminal box gasket
	(1240)	Lid gasket
	1290	Spacer ring
	1300	d.c. brake type FD
	1310	Brake disc
	1320	Brake springs

kit	ref.	Description
	(1325)	Brake hub
KTF	(6290)	Key (brake hub)
	(6300)	Circlip
	1328	Stainless steel disc (IP55)
	1360	Hand release lever
KPF	(1370)	Grommet (IP55)
	(6080)	V-ring (IP55)
	1390	ac/dc rectifier
KSA	(6020)	Bearing
	(6030)	Bearing
	(6050)	Compensation ring
	(6060)	Key
	(6070)	Seal ring
	6234	Blank plug
	6250	Terminal board

(####) Only available as a complete kit

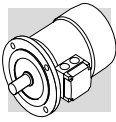

MXN

MNN

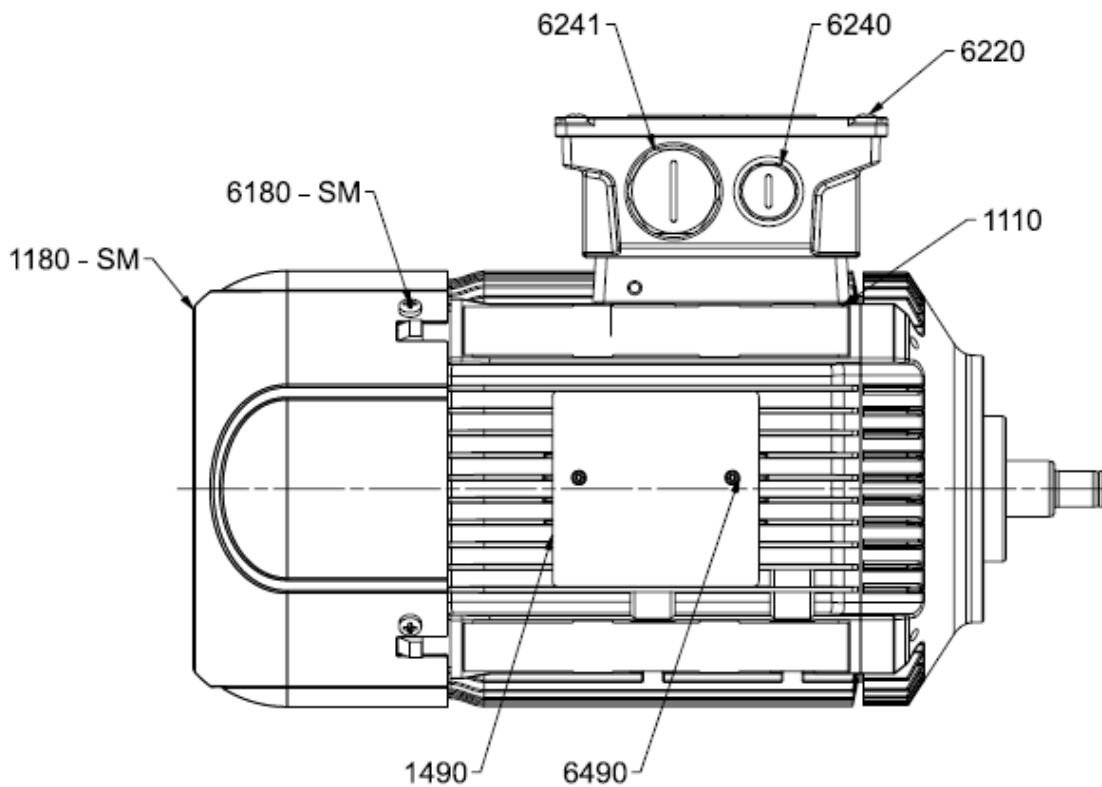
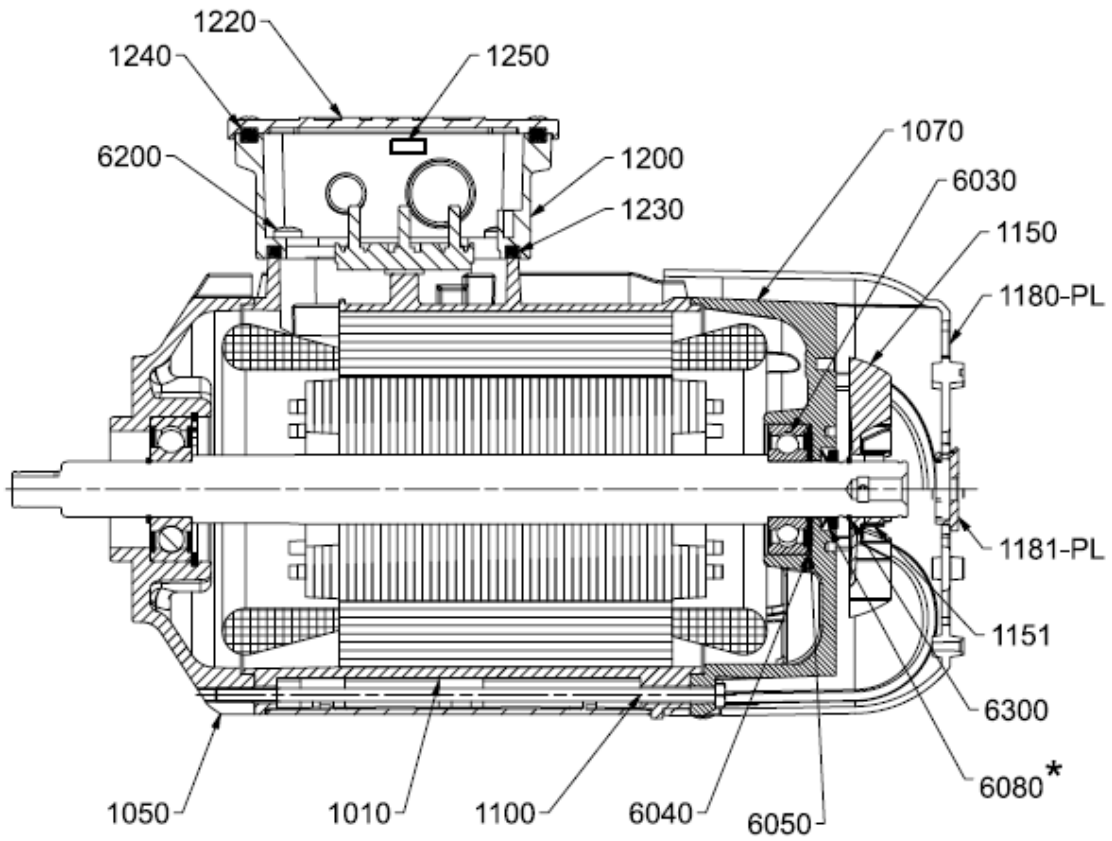

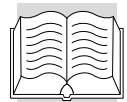
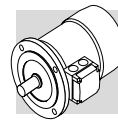

MXN FD

MNN FD

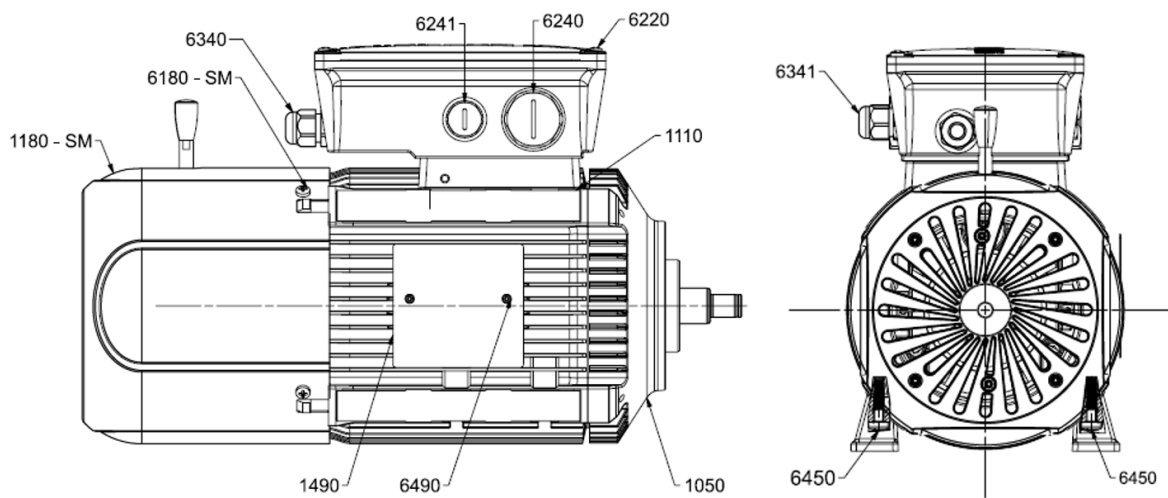
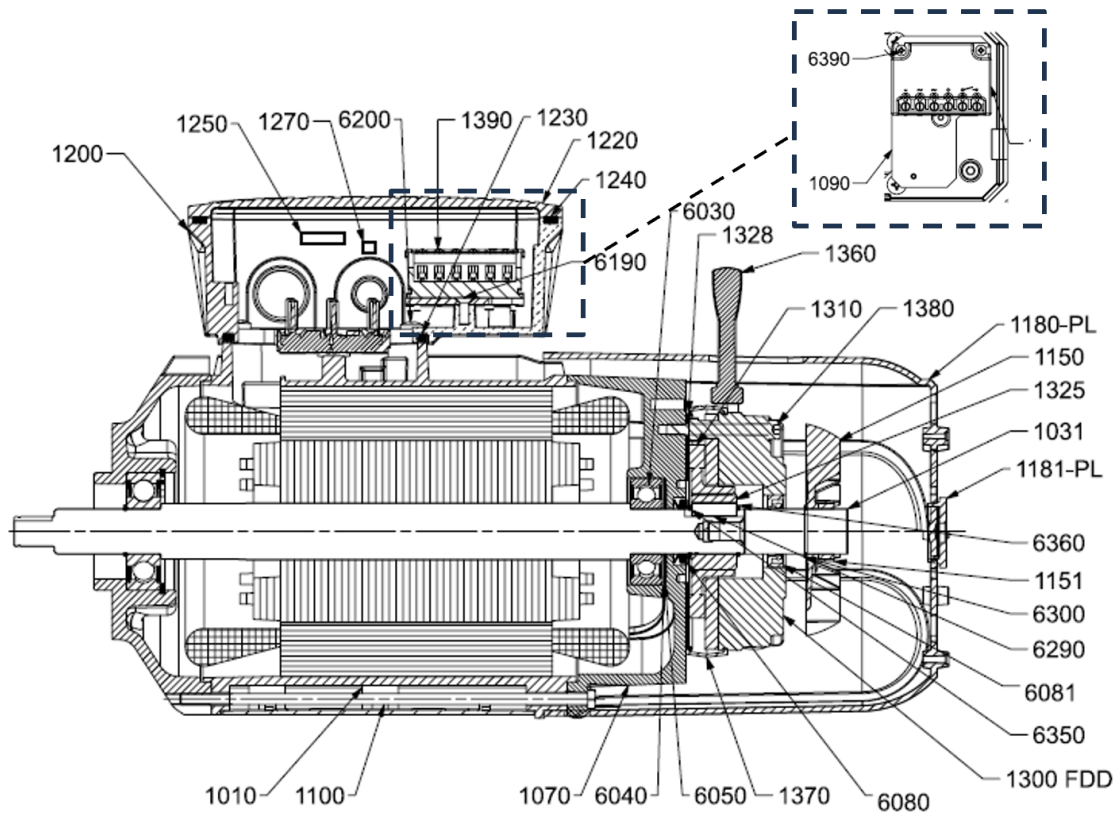

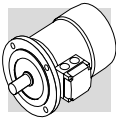

	ref.	Description
	1010	HWS
	1030	Finished rotor
	1050	Flange B5
	1100	Tie-rod
	1110	Tie-rod cover
	1150	Fan
	1151	Fan clamp ring
	1180_PL	Fan cover
	1181_PL	Fan cover cap
	1180_SM	Metal Fan cover
	6180_SM	Screw Metal Fan cover UNI8112
MXN FD	1200	Terminal box base
MNN FD	1220	Terminal box cover
	1230	Terminal box gasket
	1240	Cover box gasket
	1250	Terminal board fit
	1490	Name plate
	6020	Bearing DE
	6030	Bearing NDE
	6040	Shrink Disc ring
	6050	Spring washer
	6060	Key UNI 6604
	6070	Oil seal
	6080	V-ring v-12a
	6081	Brake Oil seal

	ref.	Description
	6090	Shaft protection
	6200	Screw T.C.C.I.C. UNI 8112
	6220	Screw T.C.C.I.C. UNI 7687
MXN FD	6240	Cable Gland Plug
MNN FD	6241	Cable Gland Plug
	6300	Circlip UNI 7435
	6350	Circlip UNI 7435
	6360	Circlip UNI 7435
	6490	Rivet UNI 9200
	1031	Additional shaft FDD
	1070	Motor shield
	1270	Brake instruction FDD
	1300	FDD brake
	1380	Socket Head Screw UNI5931
	1310	Brake disc
	1325	Hub
MXN FD	1328	Steel disc
MNN FD	1360	Brake release kit FDD
	1370	Gasket
	1390	Rectifier
	1090	Rectifier Plate
	6190	Screw Rectifier Plate UNI5933
	6290	Key FD
	6340	Cable gland
	6341	Cable gland (MRM & MWM)
	6390	Screw UNI 7687

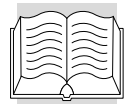
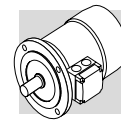

BXN

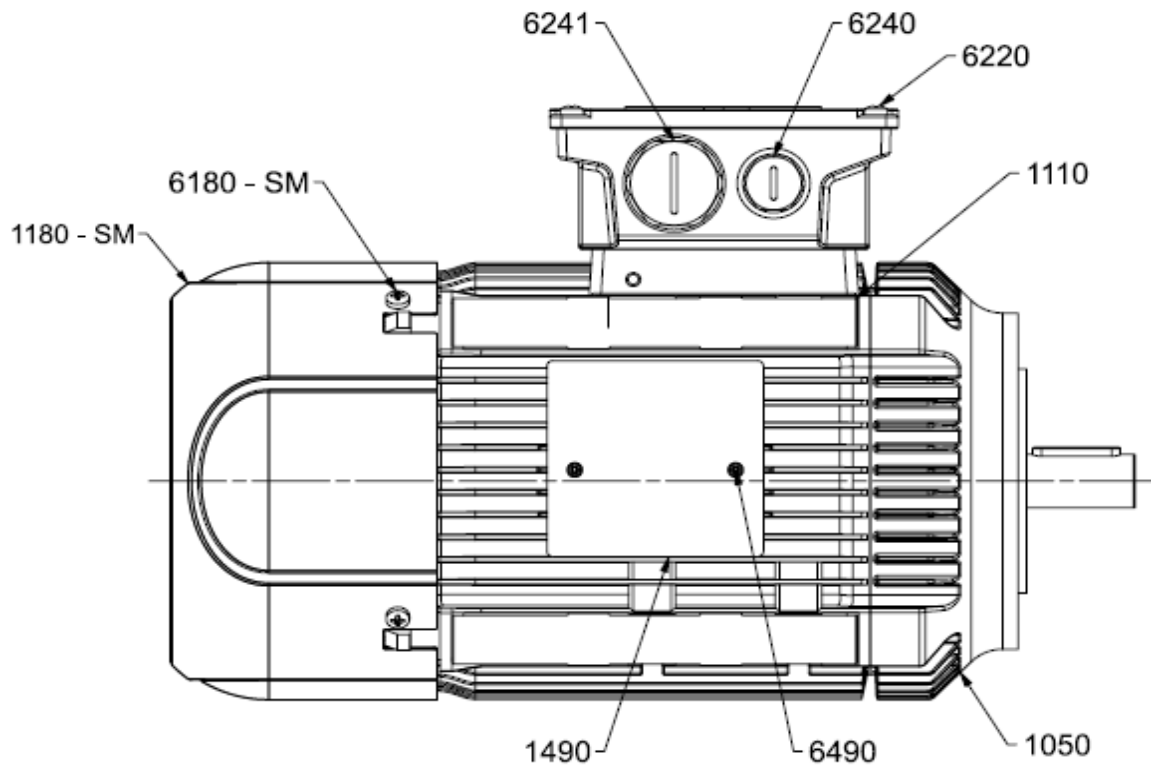
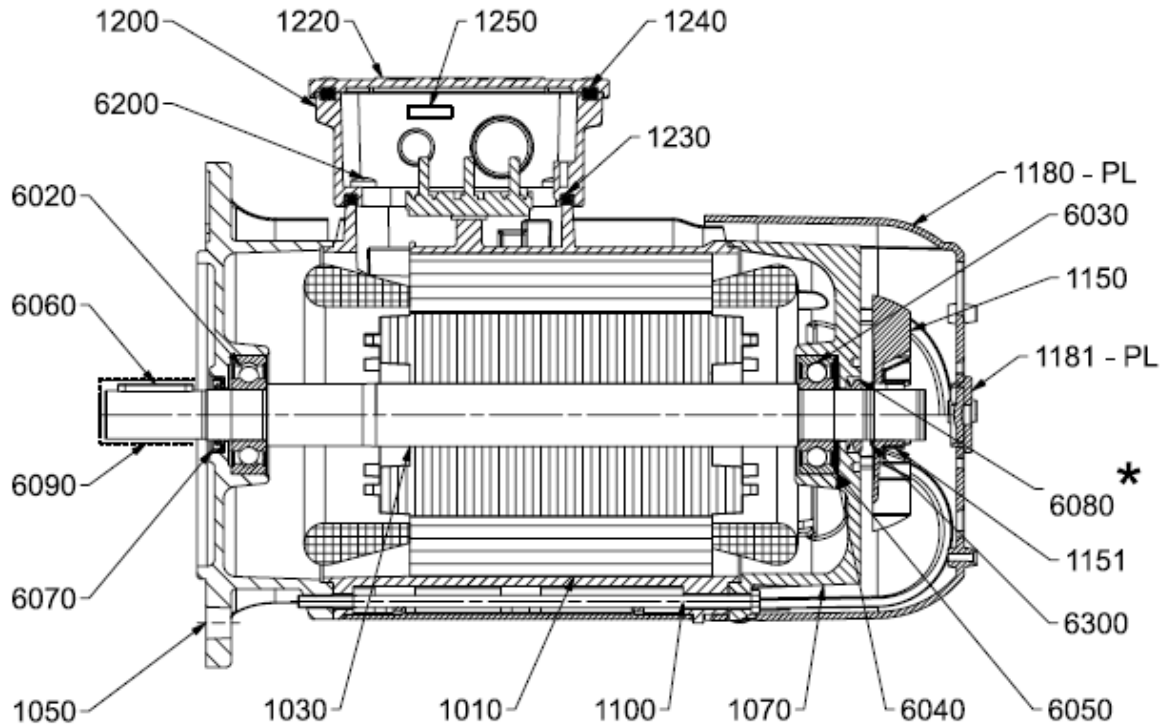

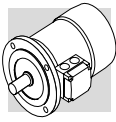

BXN FDD

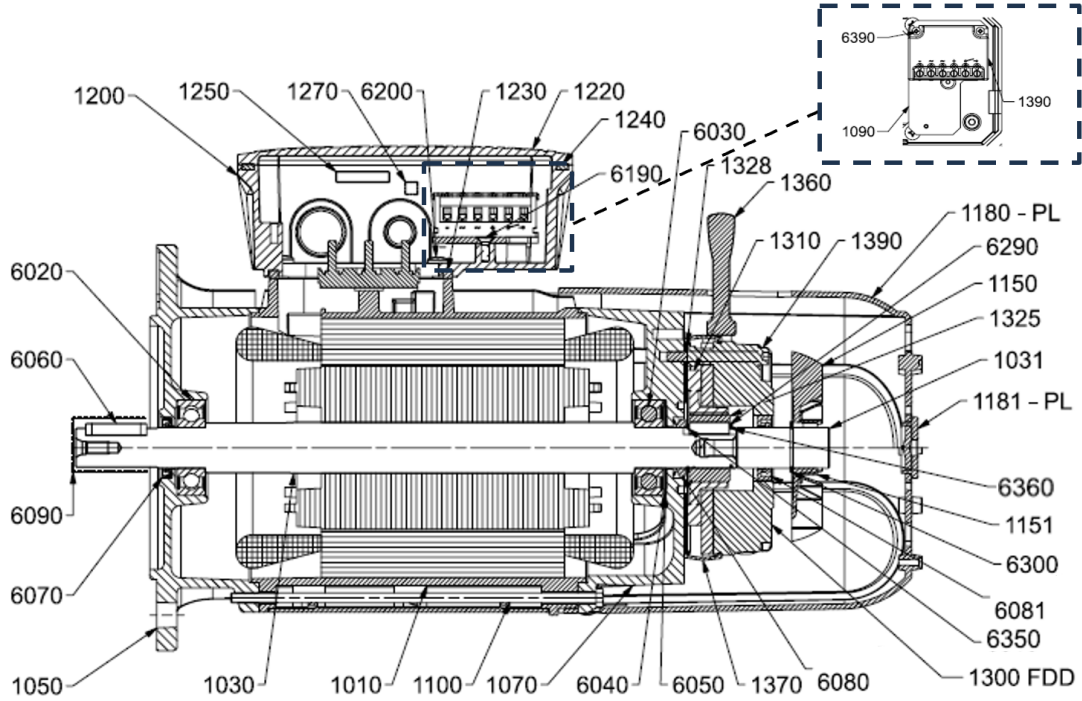

B5/B14

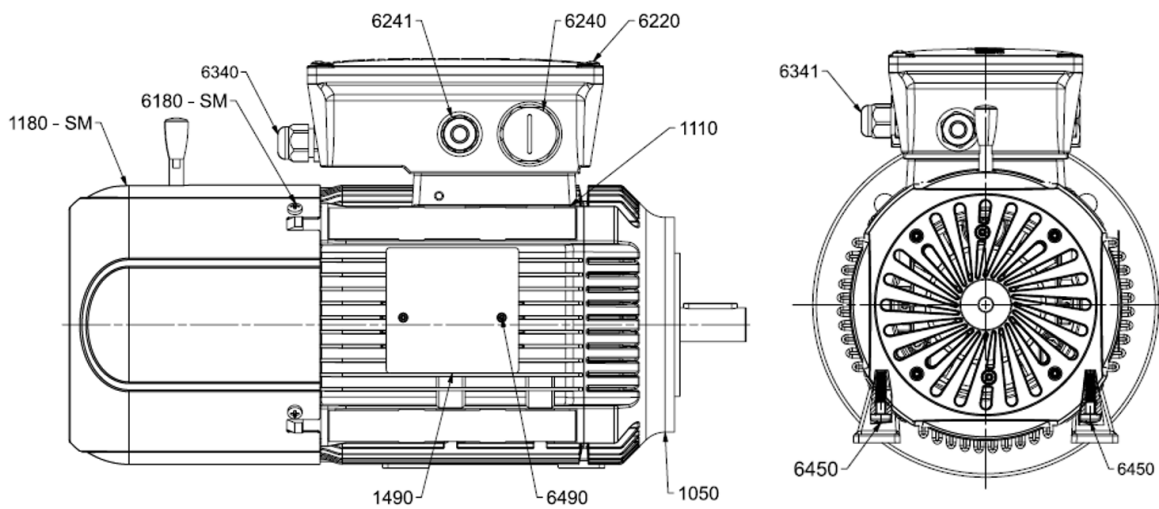

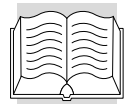
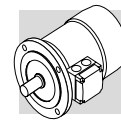

	ref.	Description
BXN FDD	1010	HWS
	1030	Finished rotor
	1050	Flange B5
	1100	Tie-rod
	1110	Tie-rod cover
	1150	Fan
	1151	Fan clamp ring
	1180_PL	Fan cover
	1181_PL	Fan cover cap
	1180_SM	Metal Fan cover
	6180_SM	Screw Metal Fan cover UNI8112
	1200	Terminal box base
	1220	Terminal box cover
	1230	Terminal box gasket
	1240	Cover box gasket
	1250	Terminal board fit
	1490	Name plate
	6020	Bearing DE
	6030	Bearing NDE
	6040	Shrink Disc ring
	6050	Spring washer
	6060	Key UNI 6604
	6070	Oil seal
	6080	V-ring v-12a
	6081	Brake Oil seal
	1010	HWS

	ref.	Description
BXN FDD	6090	Shaft protection
	6200	Screw T.C.C.I.C. UNI 8112
	6220	Screw T.C.C.I.C. UNI 7687
	6240	Cable Gland Plug
	6241	Cable Gland Plug
	6300	Circlip UNI 7435
	6350	Circlip UNI 7435
	6360	Circlip UNI 7435
BXN FDD	6490	Rivet UNI 9200
	1031	Additional shaft FDD
	1070	Motor shield
	1270	Brake instruction FDD
	1300	FDD brake
	1380	Socket Head Screw UNI5931
	1310	Brake disc
	1325	Hub
	1328	Steel disc
	1360	Brake release kit FDD
	1370	Gasket
	1390	Rectifier
	1090	Rectifier Plate
	6190	Screw Rectifier Plate UNI5933
	6290	Key FD
6340	Cable gland	
6341	Cable gland (MRM & MWM)	
6390	Screw UNI 7687	

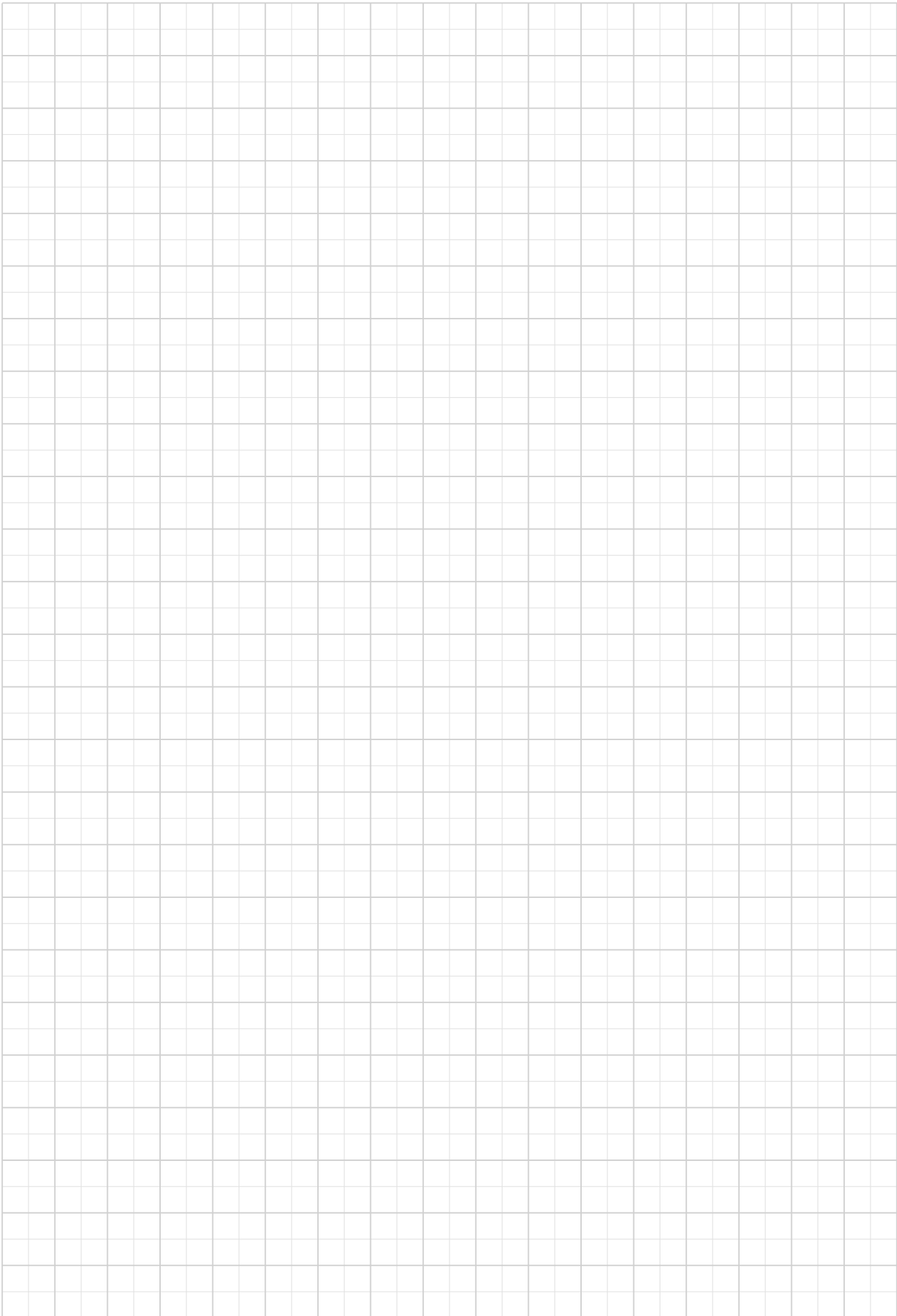
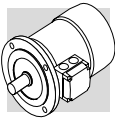

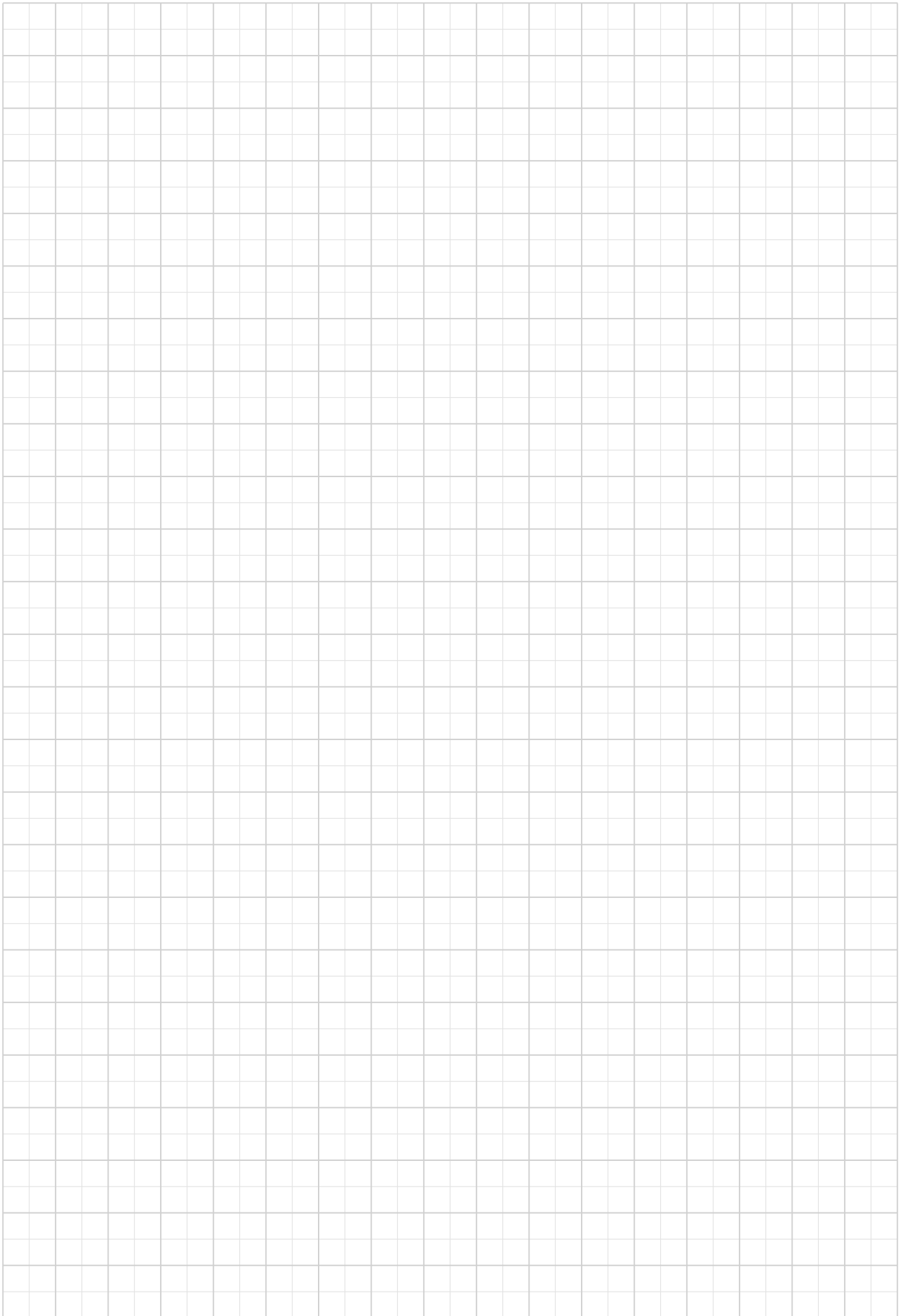
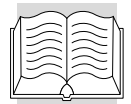
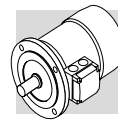

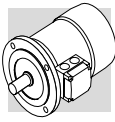

INDEX OF REVISIONS (R)

BR_IOM_BNEX_STD_ENG_R04_0	
	Description
	<ul style="list-style-type: none">- Added information about BXN, MXN, MNN motors.- New brakes on EVOX motors.

This publication supersedes and replaces any previous edition and revision. We reserve the right to implement modifications without notice. This catalogue cannot be reproduced, even partially, without prior consent.



We have a relentless commitment to excellence, innovation & sustainability. Our team creates, distributes and services world-class power transmission & drive solutions to keep the world in motion.

HEADQUARTERS

Bonfiglioli S.p.A

Via Cav. Clementino Bonfiglioli, 1
40012 Calderara di Reno - Bologna (Italy)
Tel. +39 051 6473111

