



Solutions for Warehouse & Material handling

Intralogistics



MARKETS &
APPLICATIONS



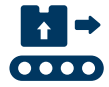

Warehouse & Material handling



We have the right solutions for all your Intralogistics needs

More than ever, intralogistics are at the heart of today's world. From automatic storage systems to warehouse vehicles, all these machines play a key role in the smooth flow of materials.

With years of experience in integrating systems and designing complete solutions for specific applications, Bonfiglioli can provide the right product to support its customers' growth in materials transport, transportation and storage technology. Efficiency, reliability, flexibility, loading capability and environmental compatibility are the pillars of the Bonfiglioli product line.

Bonfiglioli also provides solutions for:



ACCESS & AERIAL PLATFORMS



LOGISTICS & INDUSTRIAL CRANES



PACKAGING PROCESSES

www.bonfiglioli.com



Warehouse & Material handling

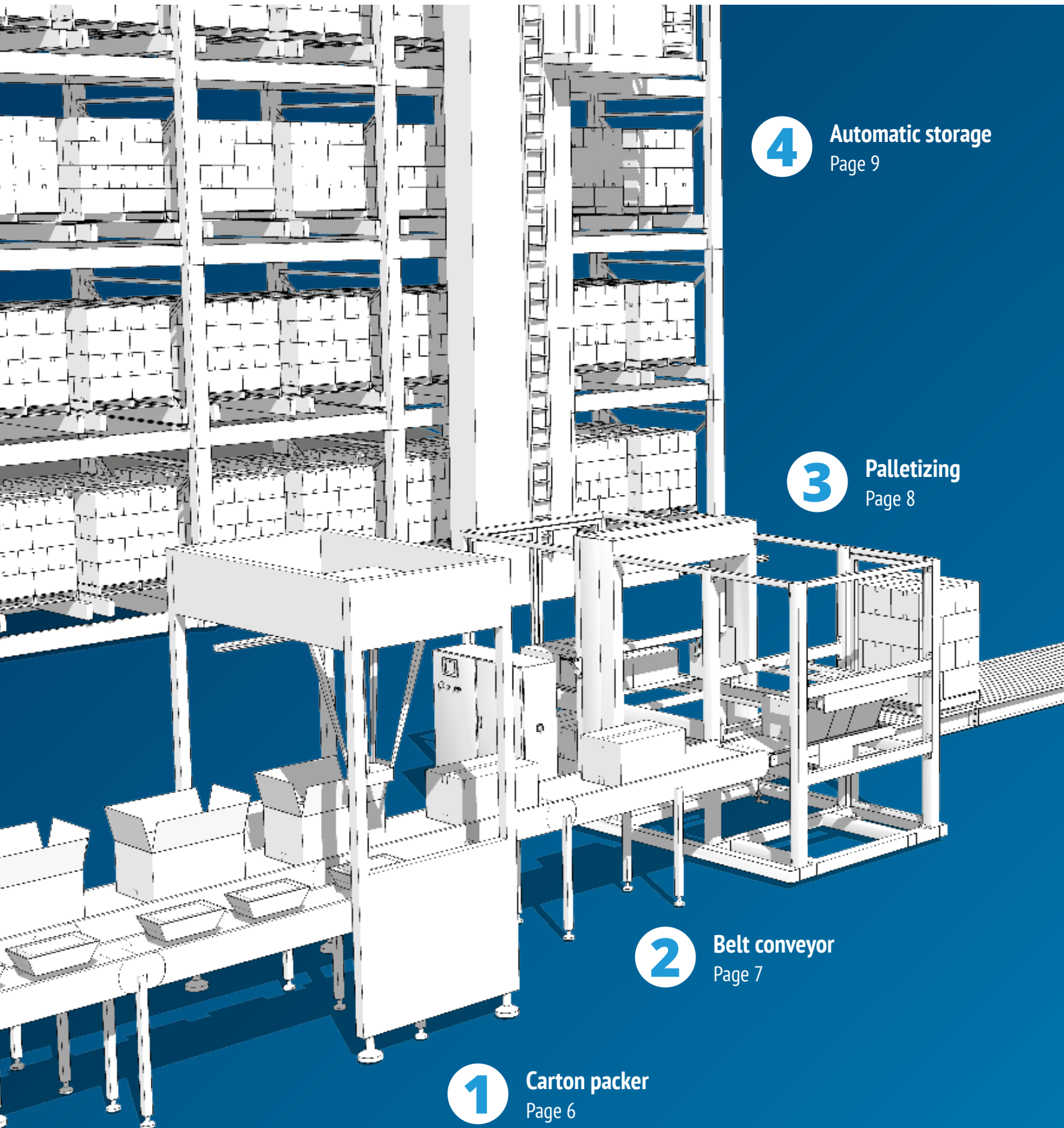

4

Automatic storage
Page 9

3

Palletizing
Page 8

2

Belt conveyor
Page 7

1

Carton packer
Page 6



Wrapping **6**
Page 11

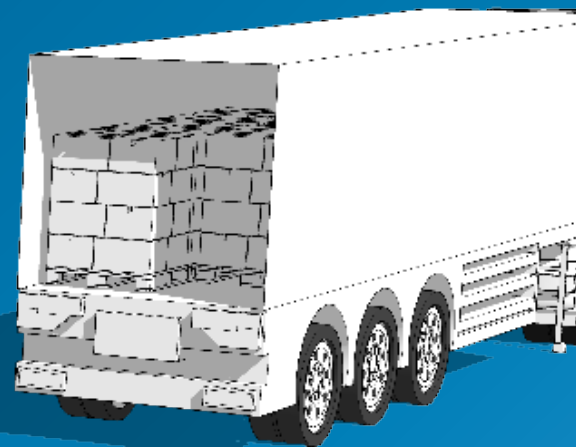
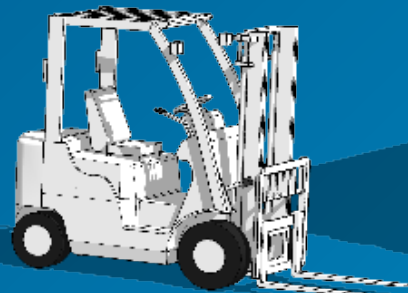
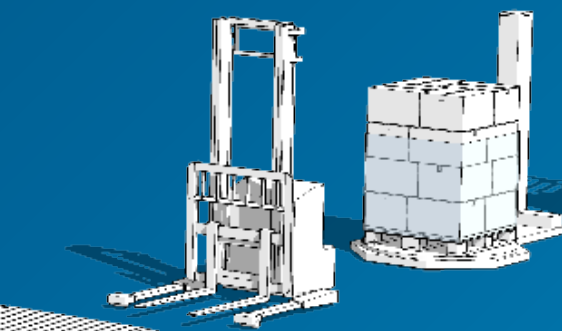

5 **Reach trucks**
Page 10

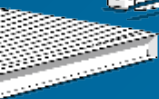

7 **Forklifts**
Page 12

Warehouse & Material handling

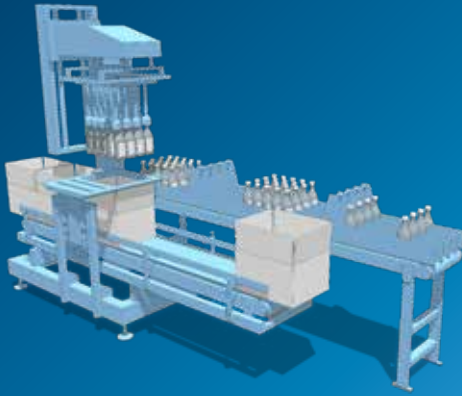

1

Carton packer

Bonfiglioli knows the challenges of these applications and provides solutions to meet them all. From maximally space-saving precision gearboxes to inverters, our customers can rely on Bonfiglioli as full line supplier.

TQ+BMD Series Servo gear units

Benefits

- High precision and dynamic
- Highly compact
- High stiffness
- Designed for continuous and intermittent duty

Features

- Different feedback systems available
- Brake option
- Inertia flywheel
- Customized windings on request

A+BMD Series Servo gear units

Benefits

- Compact
- Universal mounting
- Modular design

Features

- Keyed hollow shaft (metric and inch series)
- Super premium efficiency motors (IE4)
- Wide range of feedback devices
- Brake option
- Inertia flywheel
- Customized windings on request

Active Cube Series Premium Inverter

Benefits

- Interpolated operating mode
- Smooth start
- Torque control

Features

- Ethernet based drive
- Wide power range and parallel connection option to reach up to 1200 kW
- Integrated torque off safety function, external 24 Vd control power supply
- Tropicalization option
- Integrated PLC function with graphic development environment

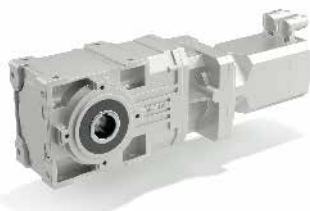

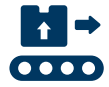

2

Belt conveyor

Belt conveyors are key elements that drive the packaging process from beginning to end. Our drives provide smooth, quiet operations and, thanks to our inverters, our solutions provide unsurpassed control of conveyor speed and motion.

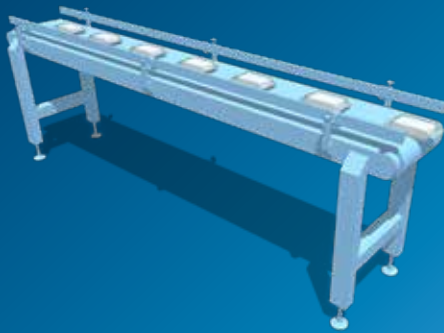

A Series Bevel-helical gearmotors

Benefits

- Compact
- Universal mounting
- Modular design

Features

- Keyed hollow shaft (metric and inch series)
- High and premium efficiency motors (IE2, IE3)
- Wide range of feedback devices (incremental and absolute encoders)

C Series Helical gearmotors

Benefits

- Top torque density
- Highly compact
- Wide speed choice

Features

- Wide choice of output bolt-on-flanges
- Special seals set for severe environment applications
- Surface protection class C3, C4 and C5 (according to UNI EN ISO 12944-2 standard)

VF-W Series Worm gearmotors

Benefits

- Cost effective
- Uncompromising quality
- Specially designed for food & beverage industries

Features

- High and premium efficiency motors (IE2, IE3)

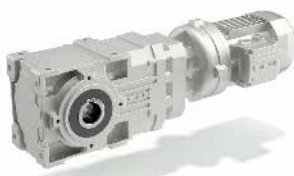

Warehouse & Material handling

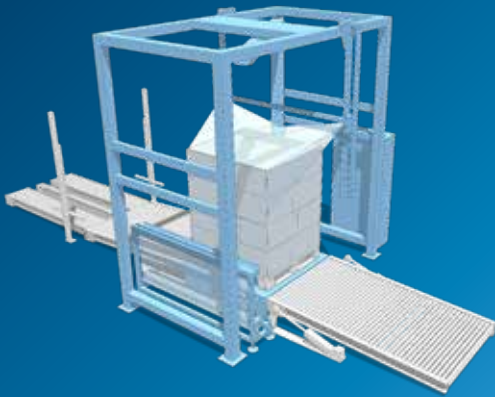

3

Palletizing

Bonfiglioli knows the challenges of these applications and provides solutions to meet them all. From maximally space-saving precision gearboxes to inverters, our customers can rely on Bonfiglioli as full line supplier.

TQ+BMD Series

Servo gear units

Benefits

- High precision and dynamic
- Highly compact
- High stiffness
- Designed for continuous and intermittent duty

Features

- Different feedback systems available
- Brake option
- Inertia flywheel
- Customized windings on request

F Series

Helical gearmotors

Benefits

- Easy installation
- Low noise
- High torque capability

Features

- Keyed Hollow Shaft - Two Bore Options per Size, Keyless Shrink Disc Fitting (Metric series)
- Keyed Hollow Shaft (Inch series)
- Back stops device
- High and premium efficiency motors (IE2, IE3)

Active Cube Series

Premium Inverter

Benefits

- Interpolated operating mode
- Smooth start
- Torque control

Features

- Ethernet based drive
- Wide power range and parallel connection option to reach up to 1200 kW
- Integrated torque off safety function, external 24 Vd control power supply
- Tropicalization option
- Integrated PLC function with graphic development environment



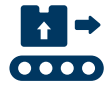

4

Automatic storage

We provide our customers with complete solutions for the highest possible precision, efficiency and energy optimization for automatic storage applications. From the inverter to the drives, Bonfiglioli is a one-stop company that understands today's market challenges.

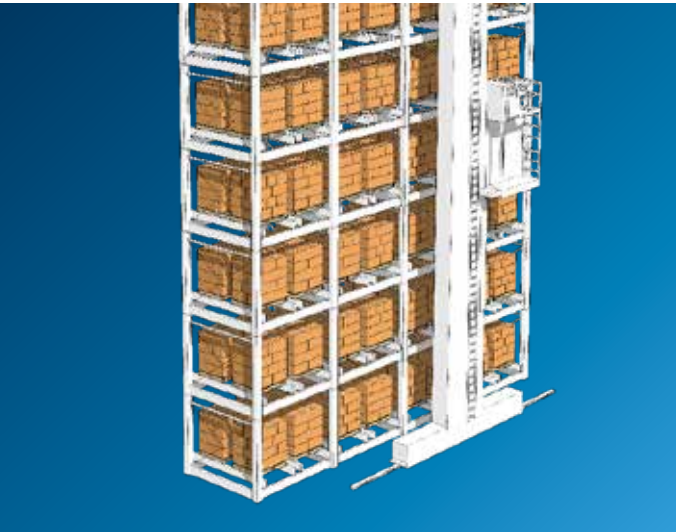

A+BMD Series Servo gear units

Benefits

- Compact
- Universal mounting
- Modular design

Features

- Keyed hollow shaft (metric and inch series)
- Super premium efficiency motors (IE4)
- Wide range of feedback devices
- Brake option
- Inertia flywheel
- Customized windings on request

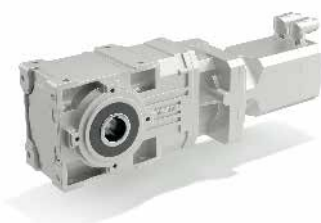

Active Cube Series Premium Inverter

Benefits

- Interpolated operating mode
- Smooth start
- Torque control

Features

- Ethernet based drive
- Wide power range and parallel connection option to reach up to 1200 kW
- Integrated torque off safety function, external 24 Vd control power supply
- Tropicalization option
- Integrated PLC function with graphic development environment



Warehouse & Material handling

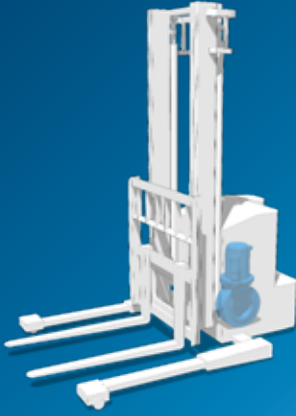

5

Reach trucks

Steerable drives

High maneuverability in tight spaces is one of the major challenges that stackers face in a warehouse. Our solutions allow the machine to operate in small vertical locations, and include the benefits of noise reduction and low maintenance cost.

EL Series

Electric wheel drives

Standard features and benefits

- High maneuverability
- Two-stage helical & bevel gearboxes
- Manual steer and power steer versions
- Optimized gear design for efficiency and noise
- Integrated low voltage electric motor and parking brake
- Complete system with tyres

Optional features available on request

- Cold environment versions
- Integrated tiller or castor wheel supports



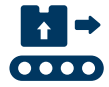

6

Wrapping

Last but not least, the tertiary phase includes both palletizing and wrapping machines to prepare the product for shipment. We provide solutions that can handle high speeds and precise movement, while stabilizing and properly aligning the material.

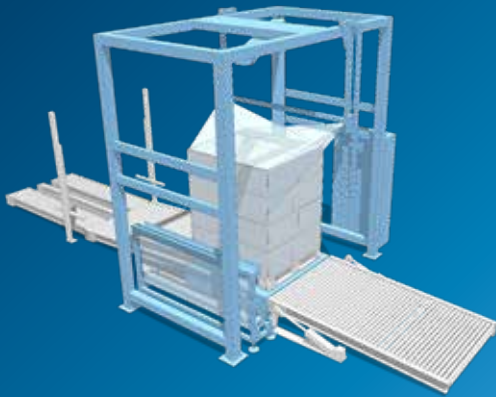

VF-W Series Worm gearmotors

Benefits

- Cost effective
- Uncompromising quality
- Specially designed for food & beverage industries

Features

- High and premium efficiency motors (IE2, IE3)

A Series Bevel-helical gearmotors

Benefits

- Compact
- Universal mounting
- Modular design

Features

- Keyed hollow shaft (metric and inch series)
- High and premium efficiency motors (IE2, IE3)
- Wide range of feedback devices (incremental and absolute encoders)

Agile Series Standard inverter

Benefits

- Smooth start
- Feed roll control
- Low energy consumption

Features

- Sensor-less vector control for asynchronous and synchronous motors
- Integrated torque off safety function
- Integrated Modbus
- Optional communication card (Profibus, CanOpen...)

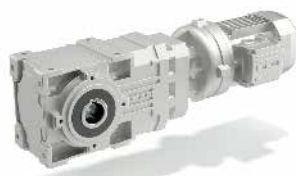

Warehouse & Material handling



Forklifts

7

Traction systems

Bonfiglioli supplies efficient, low-noise solutions with integrated, high-performance electric motors and low-maintenance brake systems for forklifts. With reduced energy consumption through longer battery life, and easy maneuverability, our products meet this typical application's requirements.

Idle steering system

For decades, Bonfiglioli has been providing the right solutions for forklift idle steering systems, lending the machine smooth operation and easy maneuverability in narrow aisles.

600F Series

Electric powertrains

Standard features and benefits

- Dual planetary gearbox
- Optimised gear design for maximum efficiency and minimum noise
- Wet disc service brake with low displacement actuation
- Parking brake with mechanical lever actuation
- Integrated, customised mast support
- Integrated AC traction motor in IP20 or IP43 protection ratings
- Integrated, high accuracy, silicon based KTY temperature sensor
- Integrated, high resolution hall effect speed sensor

Optional features available on request

- Spring-applied hydraulic release parking brake
- Mechanical disengagement for towing, with no need to remove the wheel and without oil drop

600WOC Series

Idle steering System

Standard features

- Hydraulic steering
- Optimised design for steering angle

Optional features available on request

- Electric steering for 3-wheel, also with inverter
- Anti-vibration parts
- Potentiometer for steering angle





Global Presence



Bonfiglioli is a market force with a presence spanning 22 countries on 5 continents. Our organization makes the most of geographic proximity to offer complete solutions combining efficiency and competence.



3804
EMPLOYEES



20
BRANCHES



13
PLANTS



550
DISTRIBUTORS



80
COUNTRIES

We Are a Global Company

Thanks to an international network of sales branches and closely interconnecting production plants, we can guarantee the same high standards of Bonfiglioli quality anywhere at any given time. Aware that our direct presence in local markets is the key to long-lasting success, our family includes 20 sales branches, 13 production plants and more than 500 distributors around the world.

Our organization is always close by, offering complete and efficient solutions and supporting our customers with dedicated services, such as co-engineering or after-sales assistance.



Bonfiglioli Worldwide Locations

Australia

Bonfiglioli Transmission (Aust.) Pty Ltd
2, Cox Place Glendenning NSW 2761
Locked Bag 1000 Plumpton NSW 2761
Tel. +61 2 8811 8000



Brazil

Bonfiglioli Redutores do Brasil Ltda
Travessa Cláudio Armando 171 - Bloco 3
CEP 09861-730 - Bairro Assunção
São Bernardo do Campo - São Paulo
Tel. +55 11 4344 2322



China

Bonfiglioli Drives (Shanghai) Co. Ltd.
#68, Hui-Lian Road, QingPu District,
201707 Shanghai
Tel. +86 21 6700 2000



France

Bonfiglioli Transmission s.a.
14 Rue Eugène Pottier
Zone Industrielle de Moimont II
95670 Marly la Ville
Tel. +33 1 34474510



Germany

Bonfiglioli Deutschland GmbH
Sperberweg 12 - 41468 Neuss
Tel. +49 0 2131 2988 0



Bonfiglioli Vectron GmbH

Europark Fichtenhain B6 - 47807 Krefeld
Tel. +49 0 2151 8396 0



O&K Antriebstechnik GmbH

Ruhrallee 8-12 - 45525 Hattingen
Tel. +49 0 2324 2050 1



India

Bonfiglioli Transmission Pvt. Ltd.
Mobility & Wind Industries
AC 7 - AC 11 Sidco Industrial Estate
Thirumudivakkam Chennai - 600 044
Tel. +91 844 844 8649



Discrete Manufacturing & Process Industries - Mechatronic & Motion

Survey No. 528/1
Perambakkam High Road Mannur Village,
Sriperumbudur Taluk Chennai - 602 105
Tel. +91 844 844 8649



Discrete Manufacturing & Process Industries

Plot No.A-9/5, Phase IV MIDC Chakan,
Village Nighoje Pune - 410 501
Tel. +91 844 844 8649



Italy

Bonfiglioli Riduttori S.p.A.
Discrete Manufacturing & Process Industries
Via Bazzane, 33/A
40012 Calderara di Reno
Tel. +39 051 6473111



Mobility & Wind Industries

Via Enrico Mattei, 12 Z.I. Villa Selva
47100 Forlì
Tel. +39 0543 789111



Discrete Manufacturing & Process Industries

Via Sandro Pertini lotto 7b
20080 Carpiano
Tel. +39 02985081



Bonfiglioli Mechatronic Research S.p.A

Via Unione 49 - 38068 Rovereto
Tel. +39 0464 443435/36



New Zealand

Bonfiglioli Transmission (Aust.) Pty Ltd
88 Hastie Avenue, Mangere Bridge,
2022 Auckland
PO Box 11795, Ellerslie
Tel. +64 09 634 6441



Singapore

Bonfiglioli South East Asia Pte Ltd
8 Boon Lay Way, #04-09,
8@ Tadehub 21, Singapore 609964
Tel. +65 6268 9869



Slovakia

Bonfiglioli Slovakia s.r.o.
Robotnícka 2129
Považská Bystrica, 01701 Slovakia
Tel. +421 42 430 75 64



South Africa

Bonfiglioli South Africa Pty Ltd.
55 Galaxy Avenue, Linbro Business Park,
Sandton, Johannesburg
2090 South Africa
Tel. +27 11 608 2030



Spain

Tecnotrans Bonfiglioli S.A
Pol. Ind. Zona Franca, Sector C,
Calle F, nº 6 - 08040 Barcelona
Tel. +34 93 447 84 00



Turkey

Bonfiglioli Turkey Jsc
Atatürk Organize Sanayi Bölgesi,
10007 Sk. No. 30
Atatürk Organize Sanayi Bölgesi,
35620 Çiğli - İzmir
Tel. +90 0 232 328 22 77



United Kingdom

Bonfiglioli UK Ltd.
Unit 1 Calver Quay, Calver Road, Winwick
Warrington, Cheshire - WA2 8UD
Tel. +44 1925 852667



USA

Bonfiglioli USA Inc.
3541 Hargrave Drive
Hebron, Kentucky 41048
Tel. +1 859 334 3333



Vietnam

Bonfiglioli Vietnam Ltd.
Lot C-9D-CN My Phuoc Industrial Park 3
Ben Cat - Binh Duong Province
Tel. +84 650 3577411



 PRODUCTION

 ASSEMBLY

 SALES

 SERVICE



We have a relentless commitment to excellence, innovation & sustainability. Our team creates, distributes and services world-class power transmission & drive solutions to keep the world in motion.

HEADQUARTERS

Bonfiglioli S.p.A

Registered office: Via Bazzane, 33
40012 Calderara di Reno - Bologna (Italy)
Tel. +39 051 6473111

Head office: Via Isonzo, 65/67/69
40033 Casalecchio di Reno - Bologna (Italy)

